



YAMAHA

2009

SERVICE MANUAL

VMX17Y(C)

Vmax

EAS20050

VMX17Y(C)
SERVICE MANUAL
©2008 by Yamaha Motor Corporation, U.S.A.
First edition, August 2008
All rights reserved.
Any reproduction or unauthorized use
without the written permission of
Yamaha Motor Corporation, U.S.A.
is expressly prohibited.
Printed in U.S.A.
P/N LIT-11616-22-64

IMPORTANT

This manual was produced by the Yamaha Motor Company, Ltd. primarily for use by Yamaha dealers and their qualified mechanics. It is not possible to include all the knowledge of a mechanic in one manual. Therefore, anyone who uses this book to perform maintenance and repairs on Yamaha vehicles should have a basic understanding of mechanics and the techniques to repair these types of vehicles. Repair and maintenance work attempted by anyone without this knowledge is likely to render the vehicle unsafe and unfit for use.

This model has been designed and manufactured to perform within certain specifications in regard to performance and emissions. Proper service with the correct tools is necessary to ensure that the vehicle will operate as designed. If there is any question about a service procedure, it is imperative that you contact a Yamaha dealer for any service information changes that apply to this model. This policy is intended to provide the customer with the most satisfaction from his vehicle and to conform to federal environmental quality objectives.



Yamaha Motor Company, Ltd. is continually striving to improve all of its models. Modifications and significant changes in specifications or procedures will be forwarded to all authorized Yamaha dealers and will appear in future editions of this manual where applicable.

TIP

- This Service Manual contains information regarding periodic maintenance to the emission control system. Please read this material carefully.
- Designs and specifications are subject to change without notice.

IMPORTANT MANUAL INFORMATION

Particularly important information is distinguished in this manual by the following notations.

	<p>This is the safety alert symbol. It is used to alert you to potential personal injury hazards. Obey all safety messages that follow this symbol to avoid possible injury or death.</p>
	<p>A WARNING indicates a hazardous situation which, if not avoided, could result in death or serious injury.</p>
	<p>A NOTICE indicates special precautions that must be taken to avoid damage to the vehicle or other property.</p>
<p>TIP</p>	<p>A TIP provides key information to make procedures easier or clearer.</p>

HOW TO USE THIS MANUAL

This manual is intended as a handy, easy-to-read reference book for the mechanic. Comprehensive explanations of all installation, removal, disassembly, assembly, repair and check procedures are laid out with the individual steps in sequential order.

- The manual is divided into chapters and each chapter is divided into sections. The current section title “1” is shown at the top of each page.
- Sub-section titles “2” appear in smaller print than the section title.
- To help identify parts and clarify procedure steps, there are exploded diagrams “3” at the start of each removal and disassembly section.
- Numbers “4” are given in the order of the jobs in the exploded diagram. A number indicates a disassembly step.
- Symbols “5” indicate parts to be lubricated or replaced. Refer to “SYMBOLS”.
- A job instruction chart “6” accompanies the exploded diagram, providing the order of jobs, names of parts, notes in jobs, etc.
- Jobs “7” requiring more information (such as special tools and technical data) are described sequentially.

5

1

CLUTCH

CLUTCH

Removing the clutch cover

12 Nm (1.2 m·kgf, 8.7 ft·lbf)

10 Nm (1.0 m·kgf, 7.2 ft·lbf)

Order	Job/Parts to remove	Qty	Remarks
	Engine oil		Drain. Refer to "CHANGING THE ENGINE OIL" on page 3-10.
1	Clutch cover	1	
2	Clutch cover gasket	1	
3	Dowel pin	2	
4	Clutch cover damper plate	1	
5	Clutch cover damper	1	
			For installation, reverse the removal procedure.

CLUTCH

REMOVING THE CLUTCH

1. Remove:

- Clutch cover "1"

TIP
Loosen each bolt 1/4 of a turn at a time, in stages and in a crisscross pattern. After all of the bolts are fully loosened, remove them.

2. Remove:

- Clutch spring plate retainers "1"
- Clutch spring plate "2"
- Clutch spring plate retainers bolts

TIP
Loosen the clutch spring plate retainers bolts in stages and in a crisscross pattern.

3. Remove:

- Long clutch push rod "1"

TIP
Push the long clutch push rod into the clutch release cylinder side of the engine, and remove it from the clutch side of the engine.

4. Loosen:

- Clutch boss nut "1"

TIP
While holding the clutch boss "2" with the universal clutch holder "3", loosen the clutch boss nut.

Universal clutch holder
90890-04086
YM-91042

CHECKING THE FRICTION PLATES

The following procedure applies to all of the friction plates.

1. Check:

- Friction plate
Damage/wear → Replace the friction plates as a set.

2. Measure:

- Friction plate thickness
Out of specification → Replace the friction plates as a set.

TIP
Measure the friction plate at four places.

Friction plate thickness
2.92-3.08 mm (0.115-0.121 in)
Wear limit
2.80 mm (0.1102 in)

SYMBOLS

The following symbols are used in this manual for easier understanding.

TIP

The following symbols are not relevant to every vehicle.



















SYMBOL	DEFINITION	SYMBOL	DEFINITION
	Serviceable with engine mounted		Gear oil
	Filling fluid		Molybdenum disulfide oil
	Lubricant		Brake fluid
	Special tool		Wheel bearing grease
	Tightening torque		Lithium-soap-based grease
	Wear limit, clearance		Molybdenum disulfide grease
	Engine speed		Silicone grease
	Electrical data		Apply locking agent (LOCTITE®).
	Engine oil		Replace the part with a new one.



TABLE OF CONTENTS

GENERAL INFORMATION	1
SPECIFICATIONS	2
PERIODIC CHECKS AND ADJUSTMENTS	3
CHASSIS	4
ENGINE	5
COOLING SYSTEM	6
FUEL SYSTEM	7
ELECTRICAL SYSTEM	8
TROUBLESHOOTING	9



GENERAL INFORMATION

IDENTIFICATION	1-1
VEHICLE IDENTIFICATION NUMBER	1-1
MODEL LABEL.....	1-1
FEATURES	1-2
OUTLINE OF THE FI SYSTEM.....	1-2
FI SYSTEM.....	1-3
OUTLINE OF THE ABS.....	1-4
ABS COMPONENT FUNCTIONS	1-9
ABS OPERATION	1-14
ABS SELF-DIAGNOSIS FUNCTION.....	1-17
ABS WARNING LIGHT AND OPERATION.....	1-20
YCC-T (YAMAHA CHIP CONTROLLED THROTTLE)/YCC-I (YAMAHA CHIP CONTROLLED INTAKE)	1-22
INSTRUMENT FUNCTIONS	1-26
IMPORTANT INFORMATION	1-34
PREPARATION FOR REMOVAL AND DISASSEMBLY	1-34
REPLACEMENT PARTS.....	1-34
GASKETS, OIL SEALS AND O-RINGS	1-34
LOCK WASHERS/PLATES AND COTTER PINS	1-34
BEARINGS AND OIL SEALS	1-35
CIRCLIPS	1-35
CHECKING THE CONNECTIONS	1-36
SPECIAL TOOLS	1-37

EAS20130

IDENTIFICATION

EAS20140

VEHICLE IDENTIFICATION NUMBER

The vehicle identification number "1" is stamped into the right side of the steering head pipe.

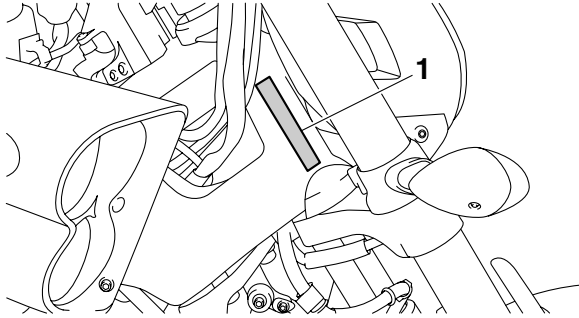

EAS20150

MODEL LABEL

The model label "1" is affixed to the frame under the rider seat. This information will be needed to order spare parts.

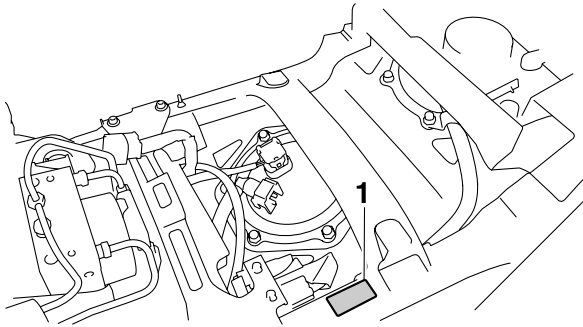

EAS20170

FEATURES

EAS30340

OUTLINE OF THE FI SYSTEM

The main function of a fuel supply system is to provide fuel to the combustion chamber at the optimum air-fuel ratio in accordance with the engine operating conditions and the atmospheric temperature. In the conventional carburetor system, the air-fuel ratio of the mixture that is supplied to the combustion chamber is created by the volume of the intake air and the fuel that is metered by the jet used in the respective carburetor.

Despite the same volume of intake air, the fuel volume requirement varies by the engine operating conditions, such as acceleration, deceleration, or operating under a heavy load. Carburetors that meter the fuel through the use of jets have been provided with various auxiliary devices, so that an optimum air-fuel ratio can be achieved to accommodate the constant changes in the operating conditions of the engine.

As the requirements for the engine to deliver more performance and cleaner exhaust gases increase, it becomes necessary to control the air-fuel ratio in a more precise and finely tuned manner. To accommodate this need, this model has adopted an electronically controlled fuel injection (FI) system, in place of the conventional carburetor system. This system can achieve an optimum air-fuel ratio required by the engine at all times by using a microprocessor that regulates the fuel injection volume according to the engine operating conditions detected by various sensors.

The adoption of the FI system has resulted in a highly precise fuel supply, improved engine response, better fuel economy, and reduced exhaust emissions.

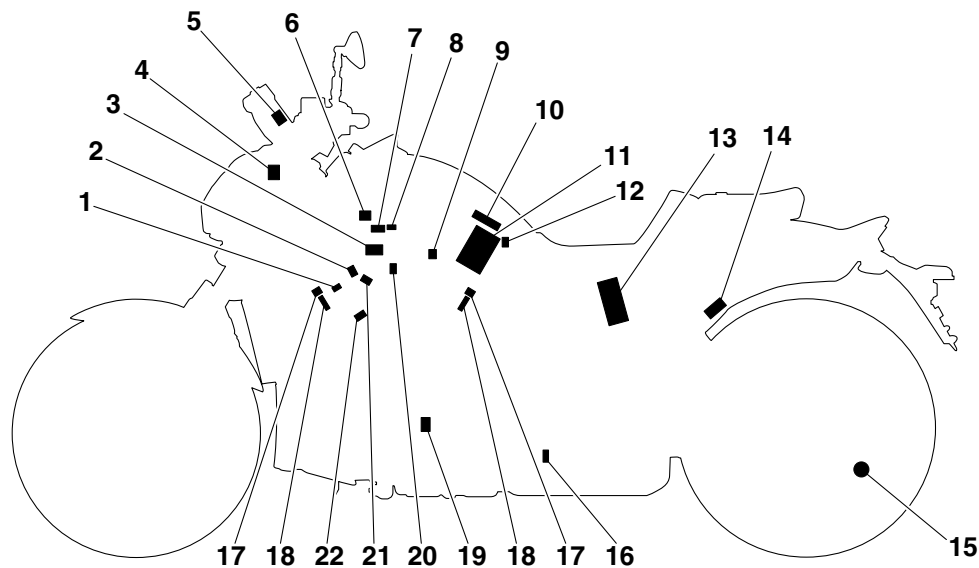

- | | |
|-----------------------------------|--------------------------------|
| 1. Cylinder identification sensor | 15. Rear wheel sensor |
| 2. Accelerator position sensor | 16. O ₂ sensor |
| 3. Throttle servo motor | 17. Ignition coil |
| 4. Intake air temperature sensor | 18. Spark plug |
| 5. Engine trouble warning light | 19. Crankshaft position sensor |
| 6. Intake funnel servo motor | 20. Fuel injector |
| 7. Air induction system solenoid | 21. Throttle position sensor |
| 8. Atmospheric pressure sensor | 22. Coolant temperature sensor |
| 9. Intake air pressure sensor | |
| 10. ECU (engine control unit) | |
| 11. Battery | |
| 12. Lean angle sensor | |
| 13. Fuel pump | |
| 14. EXUP servo motor | |

EAS2S31083

FI SYSTEM

The fuel pump delivers fuel to the fuel injector via the fuel filter. The pressure regulator maintains the fuel pressure that is applied to the fuel injector at only 324 kPa (3.24 kgf/cm², 47.0 psi). Accordingly, when the energizing signal from the ECU energizes the fuel injector, the fuel passage opens, causing the fuel to be injected into the intake manifold only during the time the passage remains open. Therefore, the longer the length of time the fuel injector is energized (injection duration), the greater the volume of fuel that is supplied. Conversely, the shorter the length of time the fuel injector is energized (injection duration), the lesser the volume of fuel that is supplied.

The injection duration and the injection timing are controlled by the ECU. Signals that are input from the throttle position sensor, accelerator position sensor, coolant temperature sensor, cylinder identification sensor, atmospheric pressure sensor, lean angle sensor, crankshaft position sensor, intake air pressure sensor, intake air temperature sensor, rear wheel sensor and O₂ sensor enable the ECU to determine the injection duration. The injection timing is determined through the signals from the crankshaft position sensor. As a result, the volume of fuel that is required by the engine can be supplied at all times in accordance with the driving conditions.

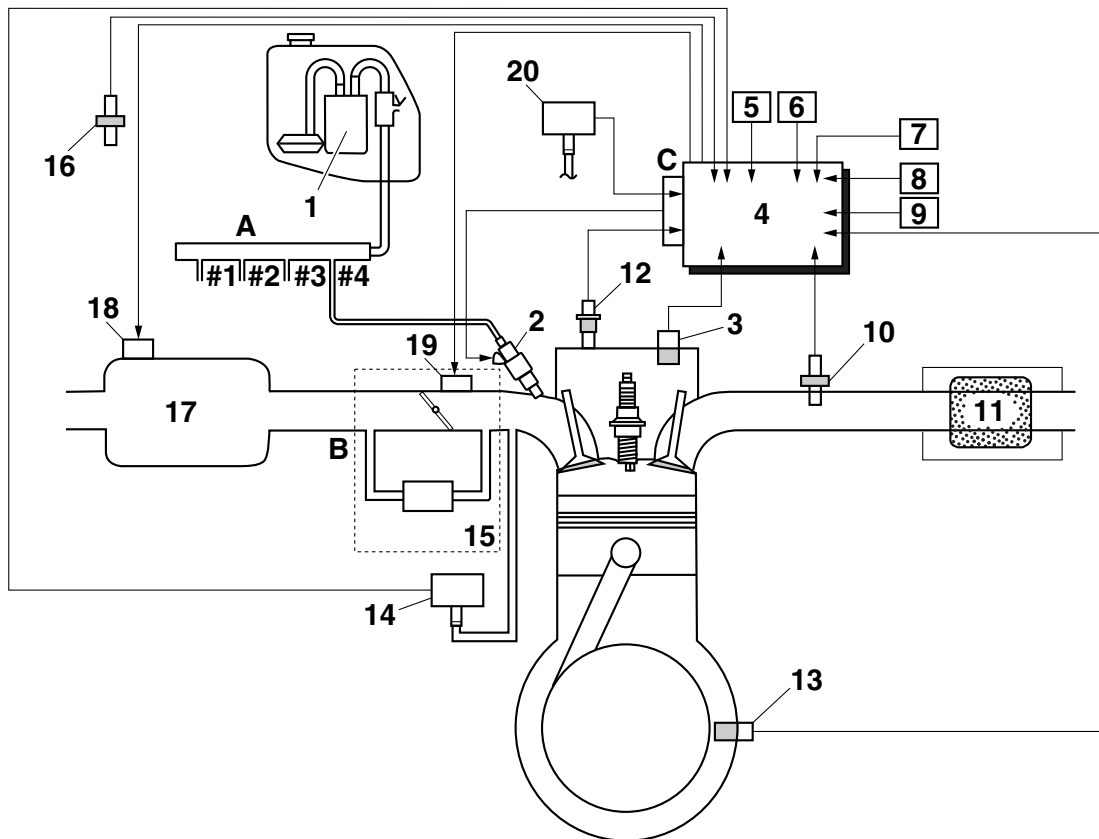

- | | |
|-----------------------------------|-----------------------------------|
| 1. Fuel pump | 13. Crankshaft position sensor |
| 2. Injector | 14. Intake air pressure sensor |
| 3. Cylinder identification sensor | 15. Throttle body |
| 4. ECU (engine control unit) | 16. Intake air temperature sensor |
| 5. Throttle position sensor | 17. Air filter case |
| 6. Accelerator position sensor | 18. Intake funnel servo motor |
| 7. Rear wheel sensor | 19. Throttle servo motor |
| 8. Lean angle sensor | 20. Atmospheric pressure sensor |
| 9. Atmospheric pressure sensor | |
| 10. O ₂ sensor | |
| 11. Catalytic converter | A. Fuel system |
| 12. Coolant temperature sensor | B. Air system |
| | C. Control system |

EAS2S31084

OUTLINE OF THE ABS

1. The Yamaha ABS (anti-lock brake system) features an electronic control system, which acts on the front and rear brakes independently.
2. The ABS features a compact and lightweight design to help maintain the basic maneuverability of the vehicle.
3. The hydraulic unit assembly, which is the main component of the ABS, is centrally located on the vehicle to increase mass centralization.

ABS layout

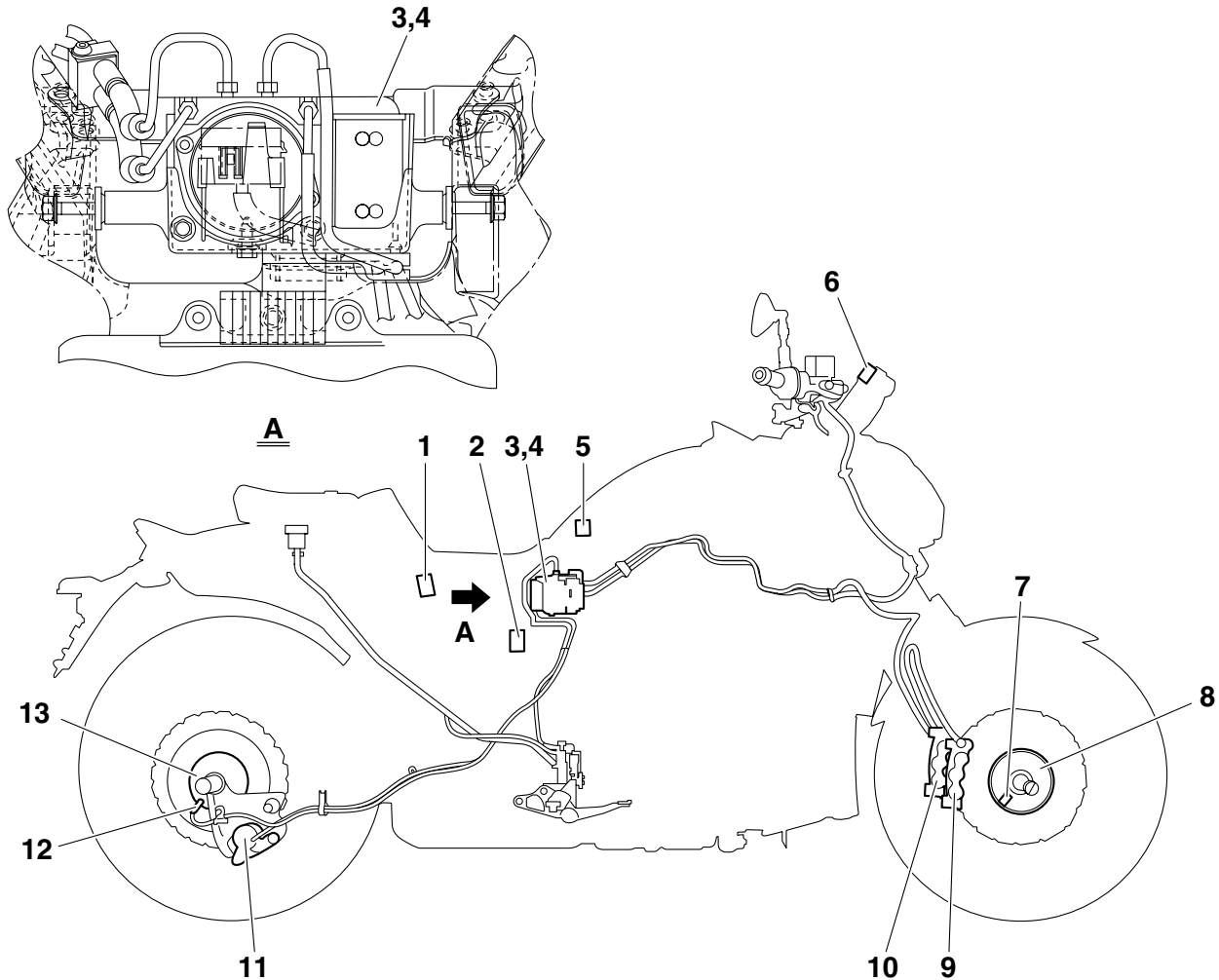

1. ABS ECU fuse
2. ABS test coupler
3. Hydraulic unit assembly
4. ABS solenoid fuse
5. ABS motor fuse
6. ABS warning light
7. Front wheel sensor

8. Front wheel sensor rotor
9. Right front brake caliper
10. Left front brake caliper
11. Rear brake caliper
12. Rear wheel sensor
13. Rear wheel sensor rotor

ABS

The operation of the Yamaha ABS brakes is the same as conventional brakes on other vehicles, with a brake lever for operating the front brake and a brake pedal for operating the rear brake. When wheel lock is detected during emergency braking, hydraulic control is performed by the hydraulic system on the front and rear brakes independently.

Useful terms

- **Wheel speed:**
The rotation speed of the front and rear wheels.
- **Chassis speed:**
The speed of the chassis.
When the brakes are applied, wheel speed and chassis speed are reduced. However, the chassis travels forward by its inertia even though the wheel speed is reduced.
- **Brake force:**
The force applied by braking to reduce the wheel speed.
- **Wheel lock:**
A condition that occurs when the rotation of one or both of the wheels has stopped, but the vehicle continues to travel.
- **Side force:**
The force on the tires which supports the vehicle when cornering.
- **Slip ratio:**
When the brakes are applied, slipping occurs between the tires and the road surface. This causes a difference between the wheel speed and the chassis speed.
Slip ratio is the value that shows the rate of wheel slippage and is defined by the following formula.

$$\text{Slip ratio} = \frac{\text{Chassis speed} - \text{Wheel speed}}{\text{Chassis speed}} \times 100 (\%)$$

0%: There is no slipping between the wheel and the road surface. The chassis speed is equal to the wheel speed.

100%: The wheel speed is "0", but the chassis is moving (i.e., wheel lock).

Brake force and vehicle stability

When the brake pressure is increased, wheel speed is reduced. Slipping occurs between the tire and the road surface and brake force is generated. The limit of this brake force is determined by the friction force between the tire and the road surface and is closely related to wheel slippage. Wheel slippage is represented by the slip ratio.

Side force is also closely related to wheel slippage. See figure "A". If the brakes are applied while keeping the proper slip ratio, it is possible to obtain the maximum brake force without losing much side force. ABS allows full use of the tires' capabilities even on slippery road surfaces or less slippery road surfaces. See figure "B".

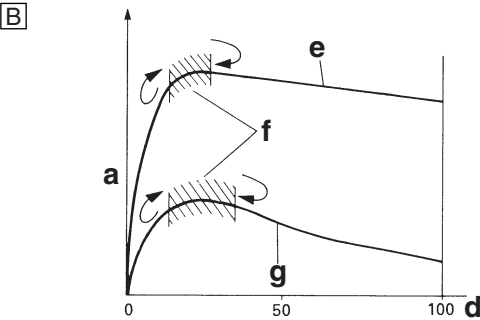
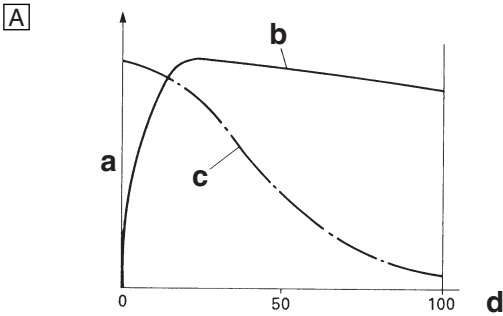

- a. Friction force between the tire and road surface
- b. Brake force
- c. Side force
- d. Slip ratio (%)
- e. Less slippery road surface
- f. Controlling zone
- g. Slippery road surface

Wheel slip and hydraulic control

The ABS ECU calculates the wheel speed of each wheel according to the rotation signal received from the front and rear wheel sensors. In addition, the ABS ECU calculates the vehicle chassis speed and the rate of speed reduction based on the wheel speed values.

The difference between the chassis speed and the wheel speed calculated in the slip ratio formula is equal to the wheel slip. When the wheel speed is suddenly reduced, the wheel has a tendency to lock. When the wheel slip and the wheel speed reduction rate exceed the preset values, the ABS ECU determines that the wheel has a tendency to lock.

If the slip is large and the wheel has a tendency to lock (point A in the following figure), the ABS ECU reduces the brake fluid pressure in the brake caliper. Once the ABS ECU determines that the tendency of the wheel to lock has diminished after the brake fluid pressure is reduced, it increases the hydraulic pressure (point B in the following figure). The hydraulic pressure is initially increased quickly, and then it is increased gradually.

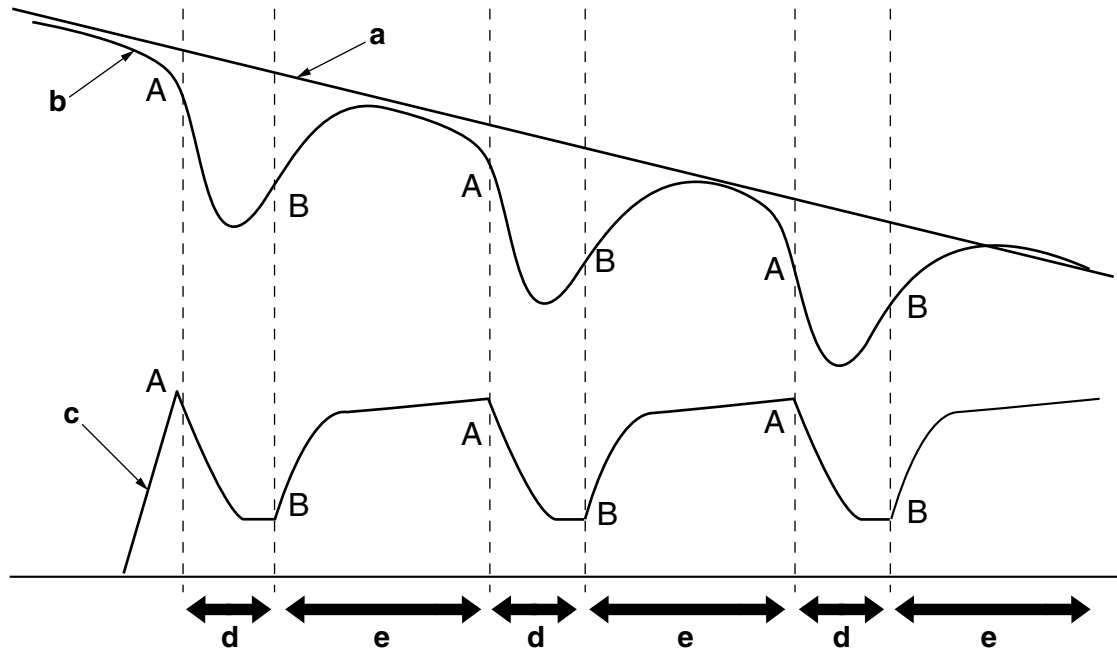

- a. Chassis speed
- b. Wheel speed
- c. Brake force

- d. Depressurizing phase
- e. Pressurizing phase

ABS operation and vehicle control

If the ABS starts operating, there is a tendency of the wheel to lock, and the vehicle is approaching the limit of control. To make the rider aware of this condition, the ABS has been designed to generate a reaction-force pulsating action in the brake lever and brake pedal independently.

TIP

When the ABS is activated, a pulsating action may be felt at the brake lever or brake pedal, but this does not indicate a malfunction.

The higher the side force on a tire, the less traction there is available for braking. This is true whether the vehicle is equipped with ABS or not. Therefore, sudden braking while cornering is not recommended. Excessive side force, which ABS cannot prevent, could cause the tire to slip sideways.

EWA2S31031

WARNING

The braking of the vehicle, even in the worst case, is principally executed when the vehicle is advancing straight ahead. During a turn, sudden braking is liable to cause a loss of traction of the tires. Even in vehicles equipped with ABS, overturning of the vehicle cannot be prevented if it is braked suddenly.

The ABS functions to prevent the tendency of the wheel to lock by controlling the brake fluid pressure. However, if there is a tendency of the wheel to lock on a slippery road surface, due to engine braking, the ABS may not be able to prevent the wheel from locking.

EWA13870

WARNING

The ABS controls only the tendency of the wheel to lock caused by applying the brakes. The ABS cannot prevent wheel lock on slippery surfaces, such as ice, when it is caused by engine braking, even if the ABS is operating.

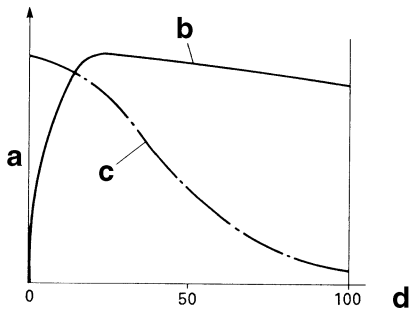

- a. Friction force between the tire and road surface
- b. Brake force
- c. Side force
- d. Slip ratio (%)

Electronic ABS features

The Yamaha ABS (anti-lock brake system) has been developed with the most advanced electronic technology.

The ABS control is processed with good response under various vehicle travel conditions.

The ABS also includes a highly developed self-diagnosis function. The ABS detects any problem condition and allows normal braking even if the ABS is not operating properly.

When this occurs, the ABS warning light on the meter assembly 1 comes on.

The ABS stores the fault codes in the memory of the ABS ECU for easy problem identification and troubleshooting.

ABS block diagram

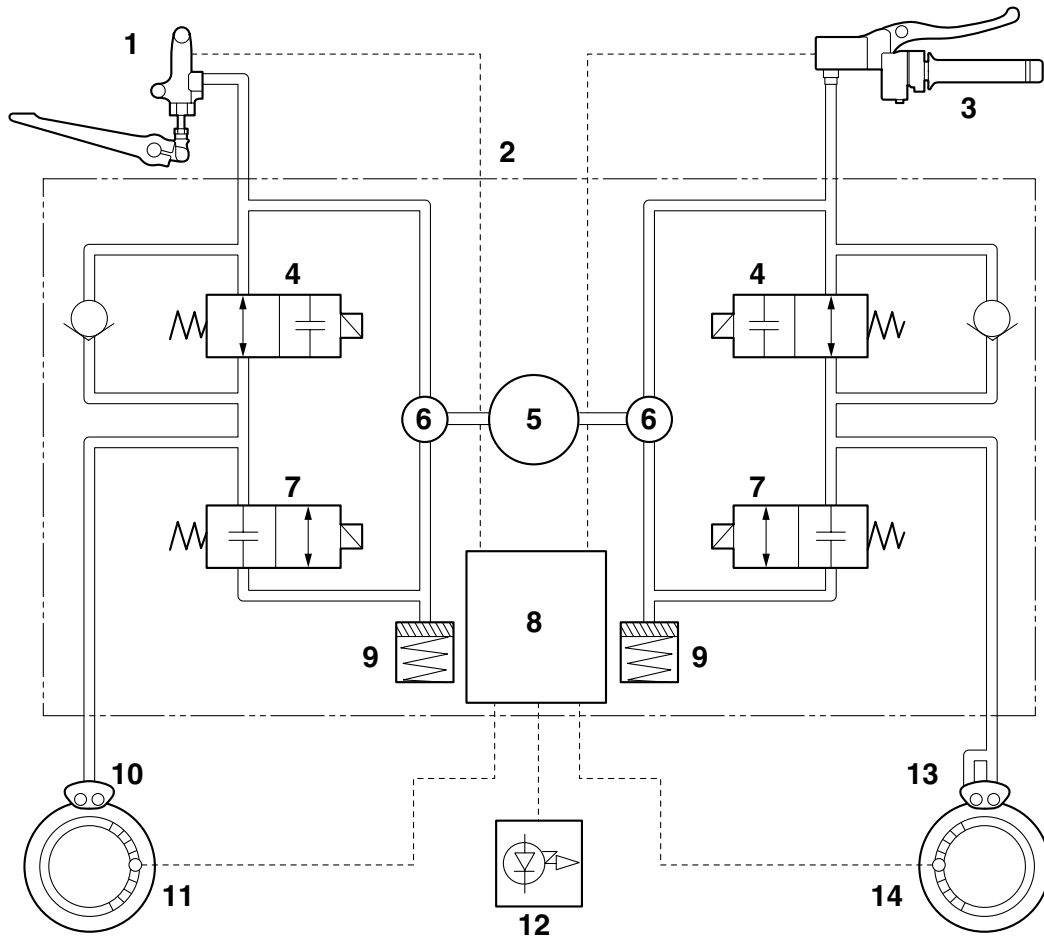

1. Rear brake master cylinder
2. Hydraulic unit assembly
3. Front brake master cylinder
4. Inlet solenoid valve
5. ABS motor
6. Hydraulic pump
7. Outlet solenoid valve
8. ABS ECU

9. Buffer chamber
10. Rear brake caliper
11. Rear wheel sensor
12. ABS warning light
13. Front brake calipers
14. Front wheel sensor

EAS2S31085

ABS COMPONENT FUNCTIONS

Wheel sensors and wheel sensor rotors

Wheel sensors “1” detect the wheel rotation speed and transmit the wheel rotation signal to the ABS ECU.

Each wheel sensor contains a Hall IC. The wheel sensors are installed in the sensor housing for each wheel.

Sensor rotors “2” are installed on the inner side of the front and rear wheel hubs and rotate with the wheels.

The front and rear sensor rotors each have 92 magnetic poles (46 pairs) and are installed close to the wheel sensors. As the sensor rotor rotates, the Hall element in the Hall IC installed in the wheel sensor generates pulses. The pulse frequency, which is proportional to the magnetic flux density, is converted into a wave in the Hall IC so that it can be output.

The ABS ECU calculates the wheel rotation speed by detecting the pulse frequency.

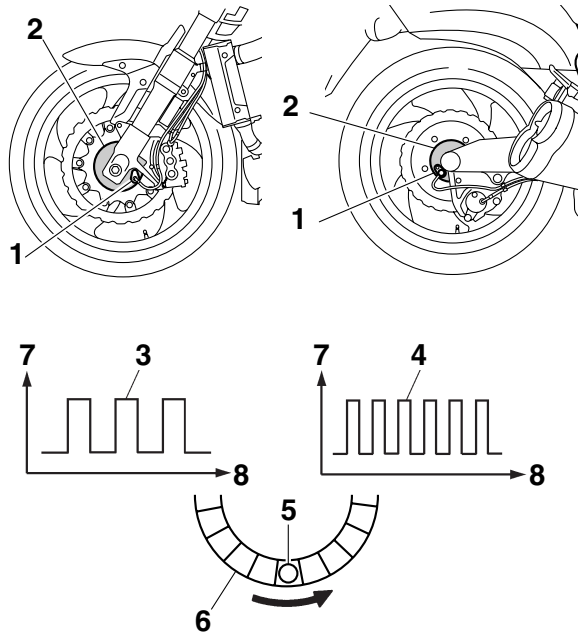

- 3. At low speed
- 4. At high speed
- 5. Wheel sensor
- 6. Wheel sensor rotor
- 7. Voltage
- 8. Time

ABS warning light

The ABS warning light “1” comes on to warn the rider if a malfunction in the ABS occurs. When the main switch is turned to “ON”, the ABS warning light comes on for 2 seconds, then goes off, so that the rider can check if the ABS warning light is disconnected and check if the ABS is operating properly.

ECA2S31063

NOTICE

If the rear wheel is raced with the vehicle on a suitable stand, the ABS warning light may flash or come on. If this occurs, turn the main switch to “OFF”, then back to “ON”. The ABS operation is normal if the ABS warning light comes on for 2 seconds, then goes off.

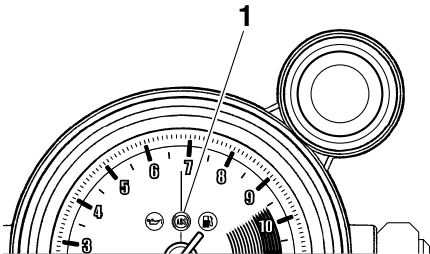

Hydraulic unit assembly

The hydraulic unit assembly “1” is composed of hydraulic control valves (each with a outlet solenoid valve and inlet solenoid valve), buffer chambers, hydraulic pumps, an ABS motor, and ABS ECU. The hydraulic unit adjusts the front and rear wheel brake fluid pressure to control the wheel speed according to signals transmitted from the ABS ECU.

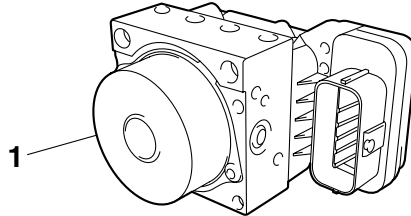

• Hydraulic control valve

The hydraulic control valve is composed of a inlet solenoid valve and outlet solenoid valve.

The electromagnetic force generated in the inlet solenoid valve varies proportionally with the duty cycle control voltage that is supplied to it. Since this voltage is continuously variable, the solenoid valve moves smoothly and the hydraulic pressure is adjusted linearly.

1. When the brakes are operated normally, the inlet solenoid valve “1” is open and the outlet solenoid valve “2” is closed. The brake line between the brake master cylinder and brake caliper is open.

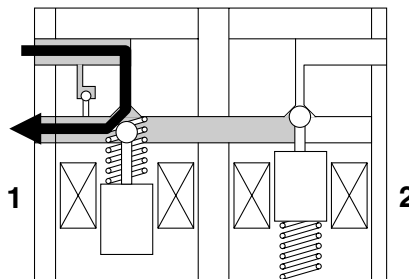

2. When the ABS is activated, the inlet solenoid valve “1” closes and the outlet solenoid valve “2” opens using the power supplied from the ABS ECU signals. This reduces the hydraulic pressure.

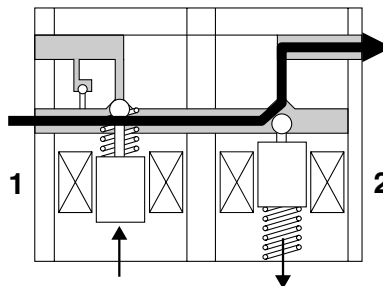

3. When the ABS ECU sends a signal to stop reducing the hydraulic pressure, the outlet solenoid valve “2” closes and the brake fluid is pressurized again. The inlet solenoid valve “1” controls the hydraulic pressure difference between the brake fluid in the upper brake lines (brake master cylinder side) and the brake fluid in the lower brake lines (brake caliper side).

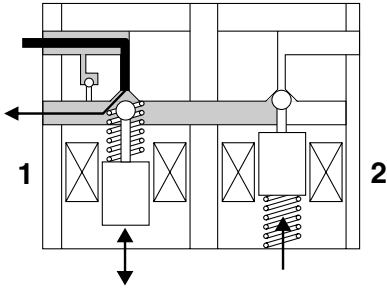

• **Buffer chamber**

The buffer chamber accumulates the brake fluid that is depressurized while the ABS is operating.

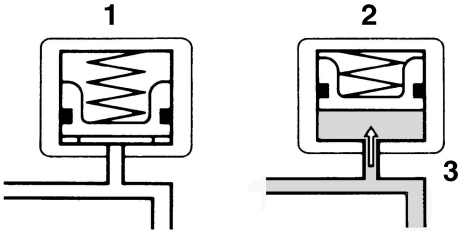

- 1. Buffer chamber (pressurizing phase)
- 2. Buffer chamber (depressurizing phase)
- 3. Raised piston

• ABS ECU

The ABS ECU is integrated with the hydraulic unit to achieve a compact and lightweight design. As shown in the block following diagram, the ABS ECU receives wheel sensor signals from the front and rear wheels and also receives signals from other monitor circuits.

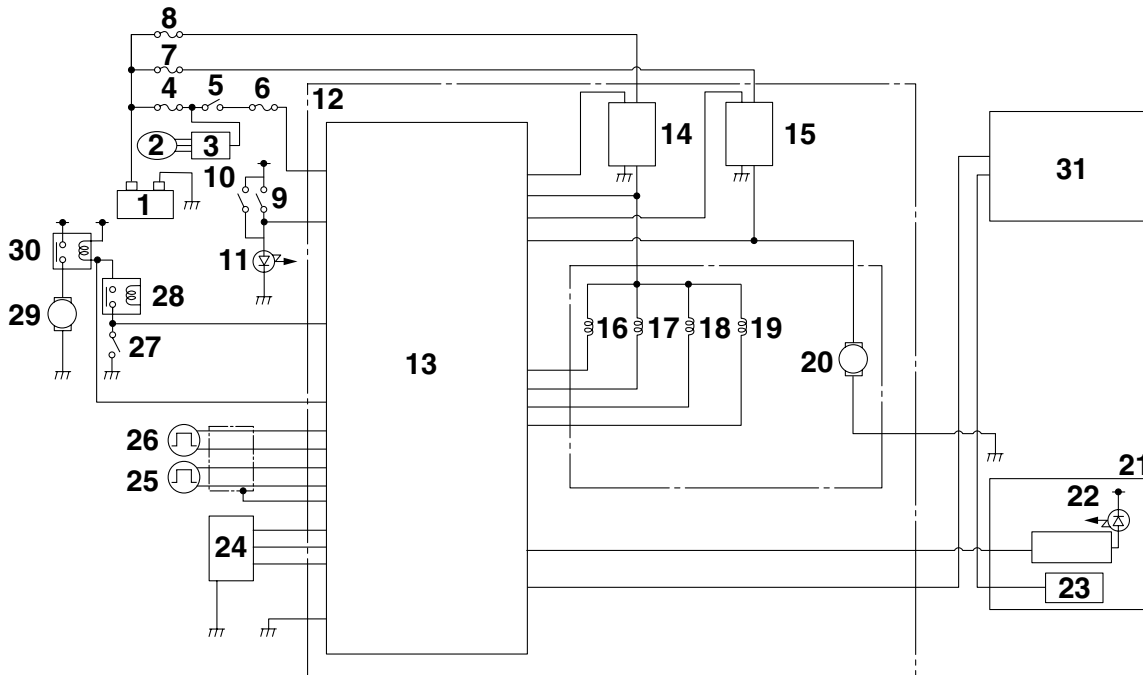

- | | |
|--------------------------------|------------------------------------|
| 1. Battery | 17. Front brake outlet solenoid |
| 2. AC magneto | 18. Rear brake inlet solenoid |
| 3. Rectifier/regulator | 19. Rear brake outlet solenoid |
| 4. Main fuse | 20. ABS motor |
| 5. Main switch | 21. Meter assembly 1 |
| 6. ABS ECU fuse | 22. ABS warning light |
| 7. ABS motor fuse | 23. Speedometer |
| 8. ABS solenoid fuse | 24. ABS test coupler |
| 9. Front brake light switch | 25. Rear wheel sensor |
| 10. Rear brake light switch | 26. Front wheel sensor |
| 11. Tail/brake light | 27. Start switch |
| 12. Hydraulic unit assembly | 28. Starting circuit cut-off relay |
| 13. ABS ECU | 29. Starter motor |
| 14. Solenoid relay | 30. Starter relay |
| 15. ABS motor relay | 31. ECU (engine control unit) |
| 16. Front brake inlet solenoid | |

The necessary actions are confirmed using the monitor circuit and control signals are transmitted to the hydraulic unit assembly.

ABS control operation

The ABS control operation performed in the ABS ECU is divided into the following two parts.

- Hydraulic control
- Self-diagnosis

When a malfunction is detected in the ABS, a fault code is stored in the memory of the ABS ECU for easy problem identification and troubleshooting.

TIP

- Some types of malfunctions are not recorded in the memory of the ABS ECU (e.g., a blown ABS ECU fuse).
- The ABS performs a self-diagnosis test for a few seconds each time the vehicle first starts off after the main switch was turned on. During this test, a “clicking” noise can be heard from under the seat, and if the brake lever or brake pedal are even slightly applied, a vibration can be felt at the lever and pedal, but these do not indicate a malfunction.

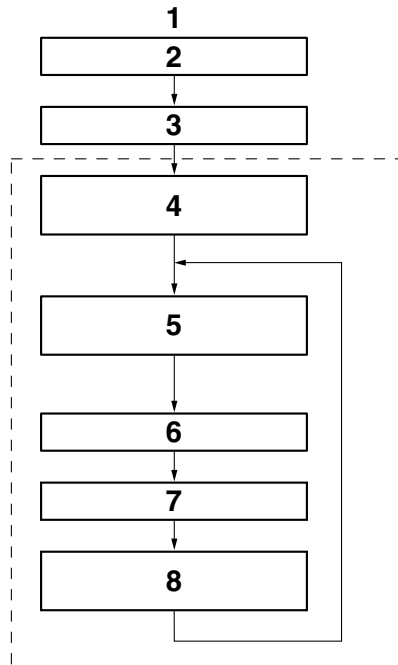

1. Software operation flow
2. Main switch “ON”
3. Initialize
4. Self-diagnosis (when static)
5. Self-diagnosis (when riding)

6. Receive signals
7. Control operation
8. Depressurize/pressurize

EAS2S31086

ABS OPERATION

The ABS hydraulic circuit consists of two systems: the front wheel, and rear wheel. The following describes the system for the front wheel only.

Normal braking (ABS not activated)

When the ABS is not activated, the inlet solenoid valve is open and the outlet solenoid valve is closed because a control signal has not been transmitted from the ABS ECU. Therefore, when the brake lever is squeezed, the hydraulic pressure in the brake master cylinder increases and the brake fluid is sent to the brake caliper.

At this time, the inlet and outlet check valves of the hydraulic pump are closed. As a result of eliminating the orifice, the brake master cylinder directly pressurizes the brake caliper during normal braking. When the brake lever is released, the brake fluid in the brake caliper returns to the brake master cylinder.

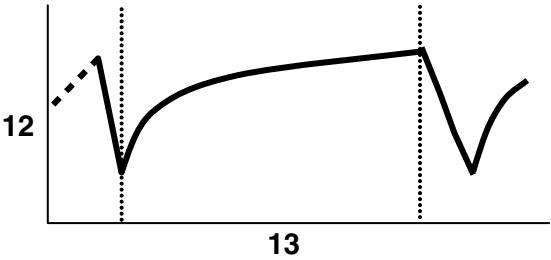
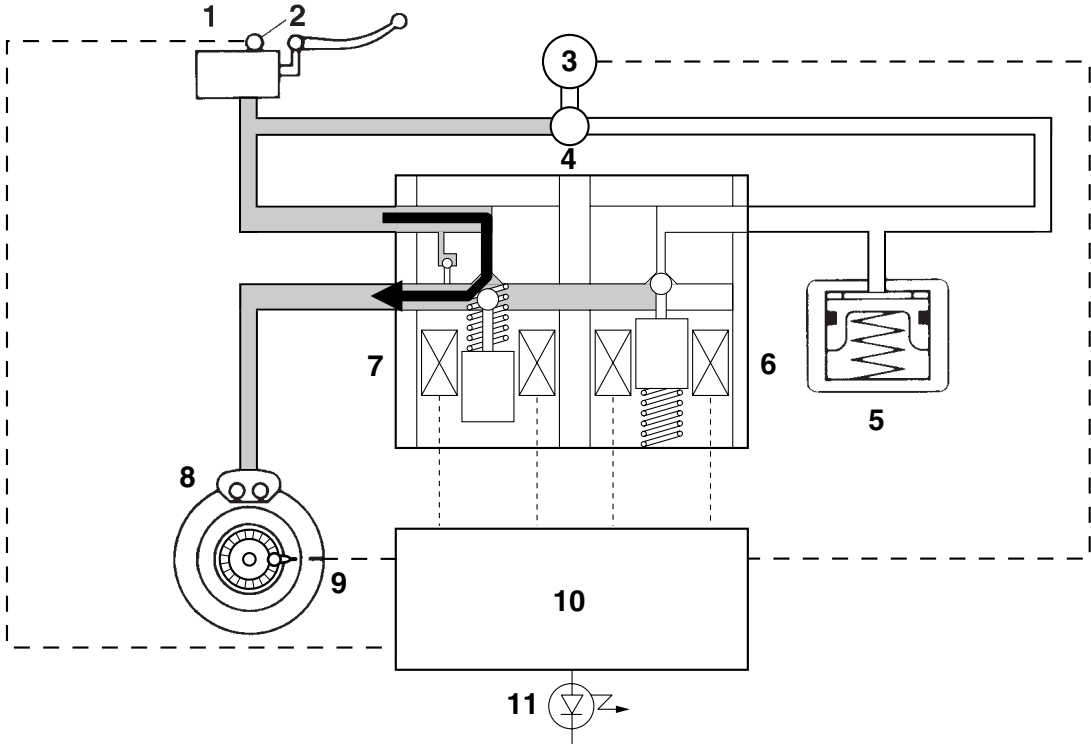

- 1. Brake master cylinder
- 2. Brake light switch
- 3. ABS motor
- 4. Hydraulic pump
- 5. Buffer chamber
- 6. Outlet solenoid valve
- 7. Inlet solenoid valve
- 8. Brake caliper
- 9. Wheel sensor
- 10. ABS ECU
- 11. ABS warning light
- 12. Brake fluid pressure
- 13. Time

Emergency braking (ABS activated)

1. Depressurizing phase

When the front wheel is about to lock, the outlet solenoid valve is opened by the “depressurization” signal transmitted from the ABS ECU. When this occurs, the inlet solenoid valve compresses the spring and closes the brake line from the brake master cylinder. Because the outlet solenoid valve is open, the brake fluid is sent to the buffer chamber. As a result, the hydraulic pressure in the brake caliper is reduced.

The brake fluid stored in the buffer chamber is pumped back to the brake master cylinder by the hydraulic pump linked to the ABS motor.

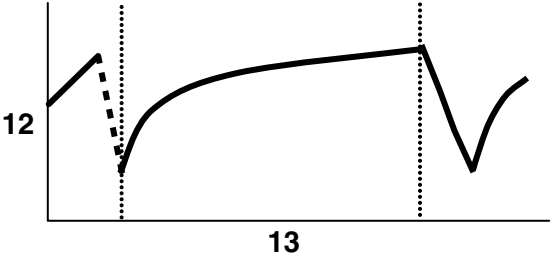
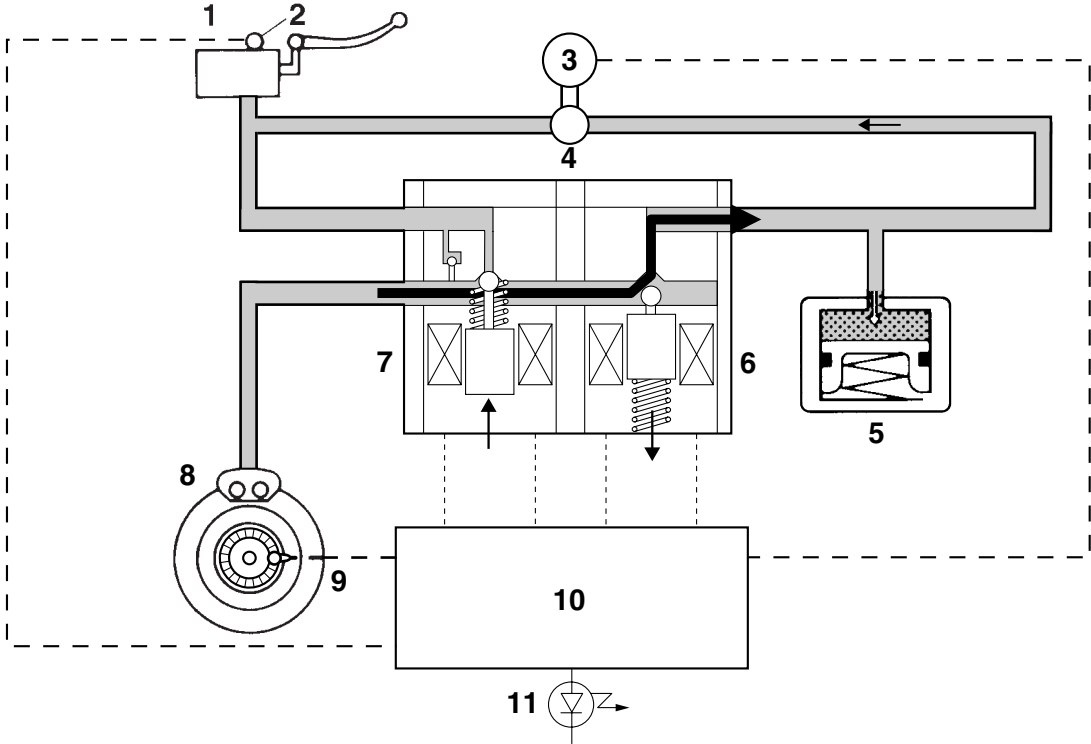

- 1. Brake master cylinder
- 2. Brake light switch
- 3. ABS motor
- 4. Hydraulic pump
- 5. Buffer chamber
- 6. Outlet solenoid valve
- 7. Inlet solenoid valve
- 8. Brake caliper
- 9. Wheel sensor
- 10. ABS ECU
- 11. ABS warning light
- 12. Brake fluid pressure
- 13. Time

2. Pressurizing phase

The outlet solenoid valve is closed by the “pressurization” signal transmitted from the ABS ECU. At this time, the ABS ECU controls the opening of the inlet solenoid valve. As the inlet solenoid valve opens, the brake line from the brake master cylinder opens, allowing the brake fluid to be sent to the brake caliper.

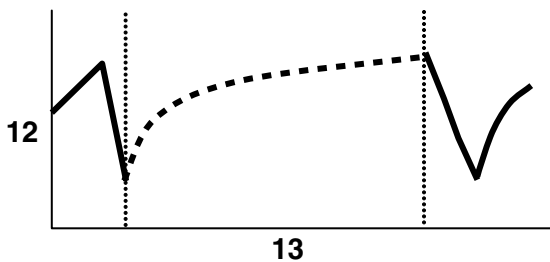
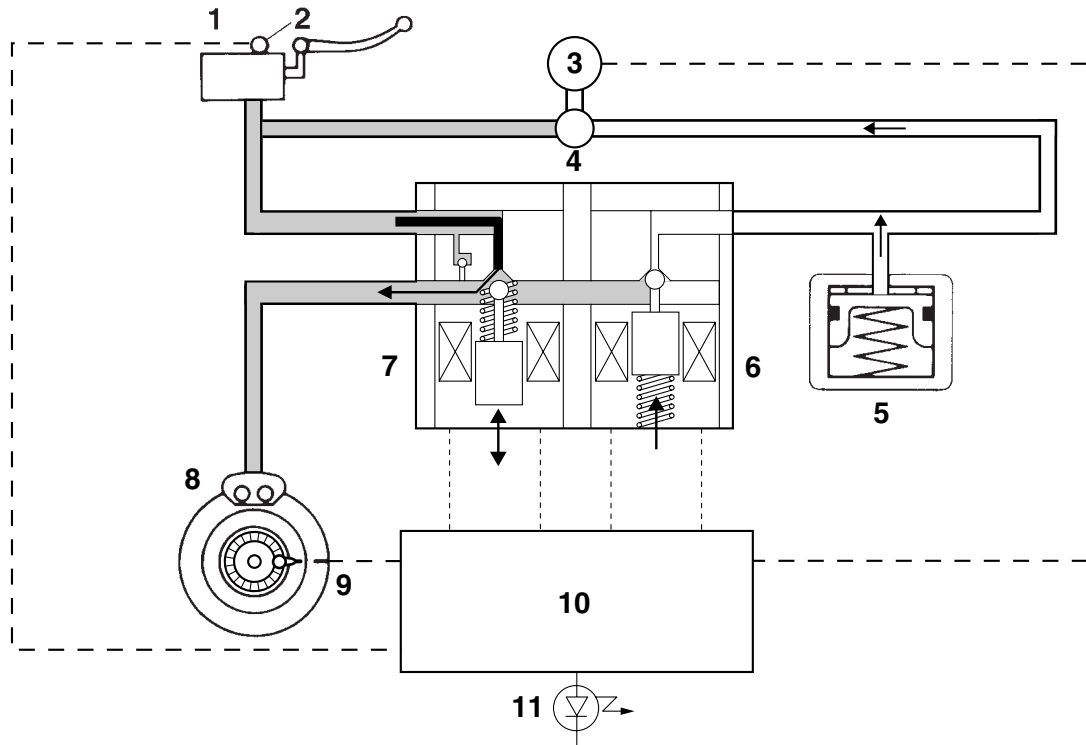

- | | |
|--------------------------|--------------------------|
| 1. Brake master cylinder | 8. Brake caliper |
| 2. Brake light switch | 9. Wheel sensor |
| 3. ABS motor | 10. ABS ECU |
| 4. Hydraulic pump | 11. ABS warning light |
| 5. Buffer chamber | 12. Brake fluid pressure |
| 6. Outlet solenoid valve | 13. Time |
| 7. Inlet solenoid valve | |

EAS2S31087

ABS SELF-DIAGNOSIS FUNCTION

ABS warning light

The ABS warning light “1” comes on when a malfunction is detected by the ABS self-diagnosis. It is located in the meter assembly 1.

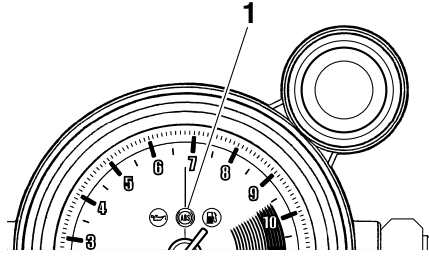

Instances when the ABS warning light comes on

1. The ABS warning light comes on when the main switch is turned to "ON".
The ABS warning light comes on for 2 seconds while the ABS is performing a self-diagnosis, then goes off if there are no problems.

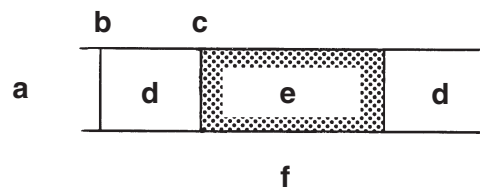

- | | |
|----------------------|---------------------------|
| a. ABS warning light | e. Comes on for 2 seconds |
| b. Main switch "OFF" | f. ABS self-diagnosis |
| c. Main switch "ON" | |
| d. Goes off | |

2. The ABS warning light comes on while the start switch is being pushed.
When the engine is being started, the ABS warning light comes on while the start switch is being pushed. (Refer to "ELECTRIC STARTING SYSTEM" on page 8-7.)

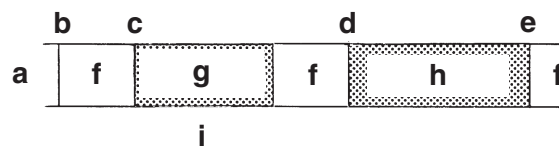

- | | |
|-----------------------|--|
| a. ABS warning light | f. Goes off |
| b. Main switch "OFF" | g. Comes on for 2 seconds |
| c. Main switch "ON" | h. Comes on while the start switch is being pushed |
| d. Start switch "ON" | i. ABS self-diagnosis |
| e. Start switch "OFF" | |

3. The ABS warning light comes on while riding.
If the ABS warning light comes on while riding, a malfunction has been detected in the ABS. The ABS hydraulic control will not be performed. The ABS will have recourse to manual braking if this occurs.

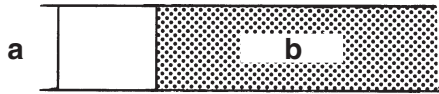

- a. ABS warning light
 - b. Comes on
4. The ABS warning light flashes while riding.
 If the ABS warning light flashes while riding, there is no problem with the function of the ABS. However, the ABS ECU input has unstable factors. (For details, refer to “ABS TROUBLESHOOTING OUTLINE” on page 8-79.)

TIP

The ABS warning light comes on or flashes if the vehicle is ridden with the test coupler adapter connected to the ABS test coupler.

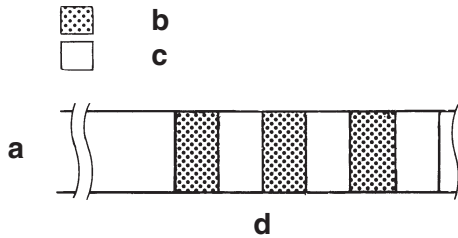

- a. ABS warning light
 - b. Comes on
 - c. Goes off
 - d. Unstable ABS ECU input
5. The ABS warning light “1” flashes and a fault code “2” is indicated on the multi-function display when the test coupler adapter “3” is connected to the ABS test coupler “4” for troubleshooting the ABS. The ABS test coupler can be accessed by removing left side cover. When the test coupler adapter is connected to the ABS test coupler, the ABS warning light starts flashing and the multi-function display indicates all the fault codes recorded in the ABS ECU.

	<p>Test coupler adapter 90890-03149</p>
---	--

TIP

The ABS warning light comes on or flashes if the vehicle is ridden with the test coupler adapter connected to the ABS test coupler.

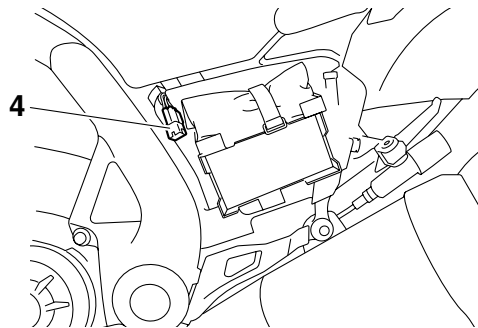
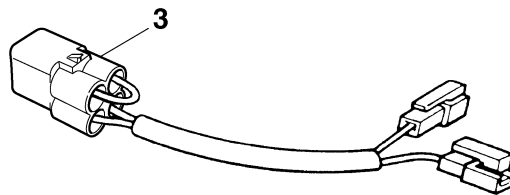
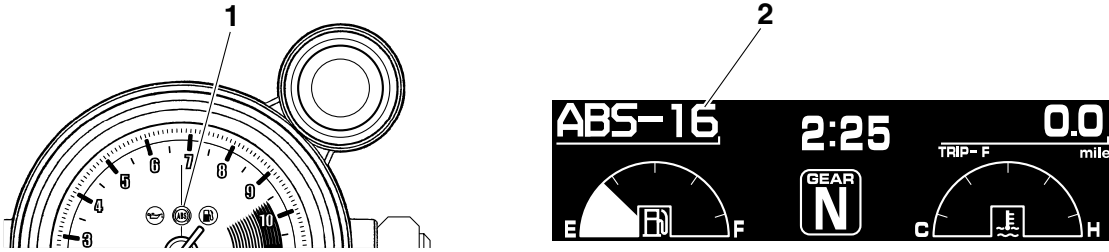

EAS2S31088

ABS WARNING LIGHT AND OPERATION

ABS warning light

- When the main switch is turned to “ON”, the ABS warning light comes on for 2 seconds, then goes off.
- The ABS warning light comes on while the start switch is being pushed.
- If the ABS warning light comes on while riding, stop the vehicle, and then turn the main switch to “OFF”, then back to “ON”. The ABS operation is normal if the ABS warning light comes on for 2 seconds, then goes off.
- If the rear wheel is raced with the vehicle on a suitable stand, the ABS warning light may flash or come on. If this occurs, turn the main switch to “OFF”, then back to “ON”. The ABS operation is normal if the ABS warning light comes on for 2 seconds, then goes off.
- The ABS operation is normal if the ABS warning light flashes.
- Even if the ABS warning light remains on and does not go off, or if it comes on after riding, conventional braking performance of the vehicle is maintained.

ABS function

EWA2S31036



- When hydraulic control is performed by the ABS, the brake system alerts the rider that the wheels have a tendency to lock by generating a reaction-force pulsating action in the brake lever or brake pedal. When the ABS is activated, the grip between the road surface and tires is close to the limit. The ABS cannot prevent wheel lock* on slippery surfaces, such as ice, when it is caused by engine braking, even if the ABS is activated.
Use extreme care when operating the vehicle under these conditions.
 - The ABS is not designed to shorten the braking distance or improve the cornering performance.
 - Depending on the road conditions, the braking distance may be longer compared to that of vehicles not equipped with ABS. Therefore, ride at a safe speed and keep a safe distance between yourself and other vehicles.
 - The braking of the vehicle, even in the worst case, is principally executed when the vehicle is advancing straight ahead. During a turn, sudden braking is liable to cause a loss of traction of the tires. Even vehicles equipped with ABS cannot be prevented from falling over if braked suddenly.
 - The ABS does not work when the main switch is turned to “OFF”. The conventional braking function can be used.
- * Wheel lock: A condition that occurs when the rotation of one or both of the wheels has stopped, but the vehicle continues to travel.
-

EAS2S31089

YCC-T (YAMAHA CHIP CONTROLLED THROTTLE)/YCC-I (YAMAHA CHIP CONTROLLED INTAKE)

Mechanism characteristics

Yamaha developed the YCC-T and YCC-I system employing the most advanced electronic control technologies. Electronic control throttle systems have been used on automobiles, but Yamaha has developed a faster, more compact system specifically for the needs of a sports motorcycle. The Yamaha-developed system has a high-speed calculating capacity that produces computations of running conditions every 1/1000th of a second.

The YCC-T system is designed to respond to the throttle action of the rider by having the ECU instantaneously calculate the ideal throttle valve opening and generate signals to operate the motor-driven throttle valves and thus actively control the intake air volume.

The ECU contains three CPUs with a capacity about five times that of conventional units, making it possible for the system to respond extremely quickly to the slightest adjustments made by the rider. In particular, optimized control of the throttle valve opening provides the optimum volume of intake air for easy-to-use torque, even in a high-revving engine.

The YCC-I system calculates the throttle values from the engine speed, activates the intake air funnels with the electronic control motor drive to control the intake pipe length in order to gain the high power output in all revolution ranges from low speeds to high speeds.

Aims and advantages of using YCC-T system

- Increased engine power
By shortening the air intake path, higher engine speed is possible → Increased engine power.
- Improved driveability
Air intake volume is controlled according to the operating conditions → Improved throttle response to meet engine requirement.
Driving force is controlled at the optimal level according to the transmission gear position and engine speed → Improved throttle control.
- Engine braking control
Due to the throttle control, optimal engine braking is made possible.
- Simplified idle speed control (ISC) mechanism
The bypass mechanism and ISC actuator are eliminated → A simple mechanism is used to maintain a steady idle speed.
- Reduced weight
Compared to using a sub-throttle mechanism, weight is reduced.

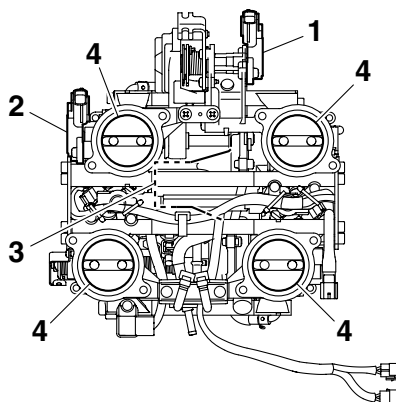
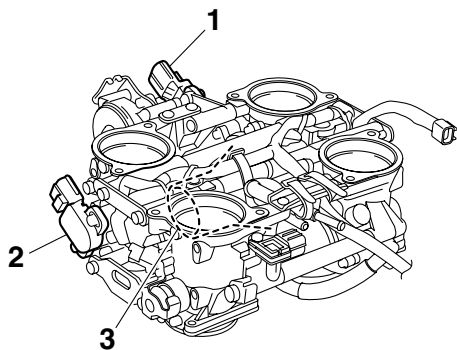

1. Accelerator position sensor
2. Throttle position sensor
3. Throttle servo motor
4. Throttle valves

Aims and advantages of using YCC-I system

- Improved power band.

By using a dual intake funnel system, YCC-I optimizes the effectiveness of the fuel injection system to deliver an incredibly precise air/fuel mixture to the combustion chamber. This degree of intake volume control gives both improved low to mid-range power, as well as improved power in the higher rpm range. In effect, the YCC-I offers higher levels of power across the RPM range.

- Electronically controlled intake length

The YCC-I system consists of four lightweight plastic resin funnels, and each of these is divided into an upper and lower portion. Depending upon operating conditions, the funnels can be joined to form a single long funnel, or split to create a short funnel. This change is performed instantaneously by an electrically controlled servo-motor which handles the function so smoothly that the rider is unaware it is happening.

A

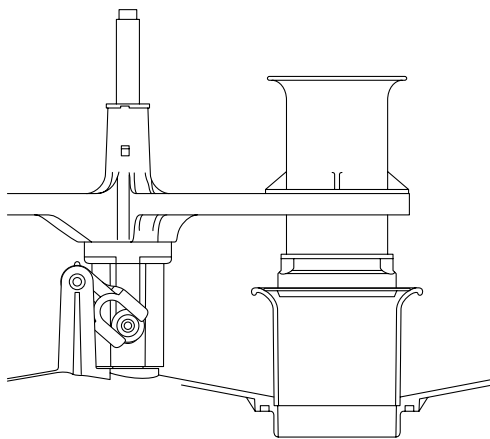

B

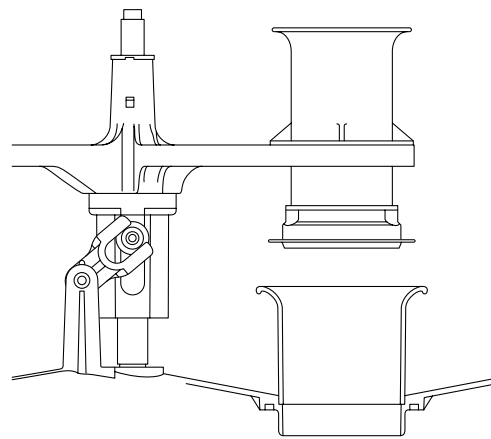

- A. Down position (long intake)
(Low rpm to Mid rpm)
- B. Up position (short intake)
(High rpm)

YCC-T/YCC-I system outline

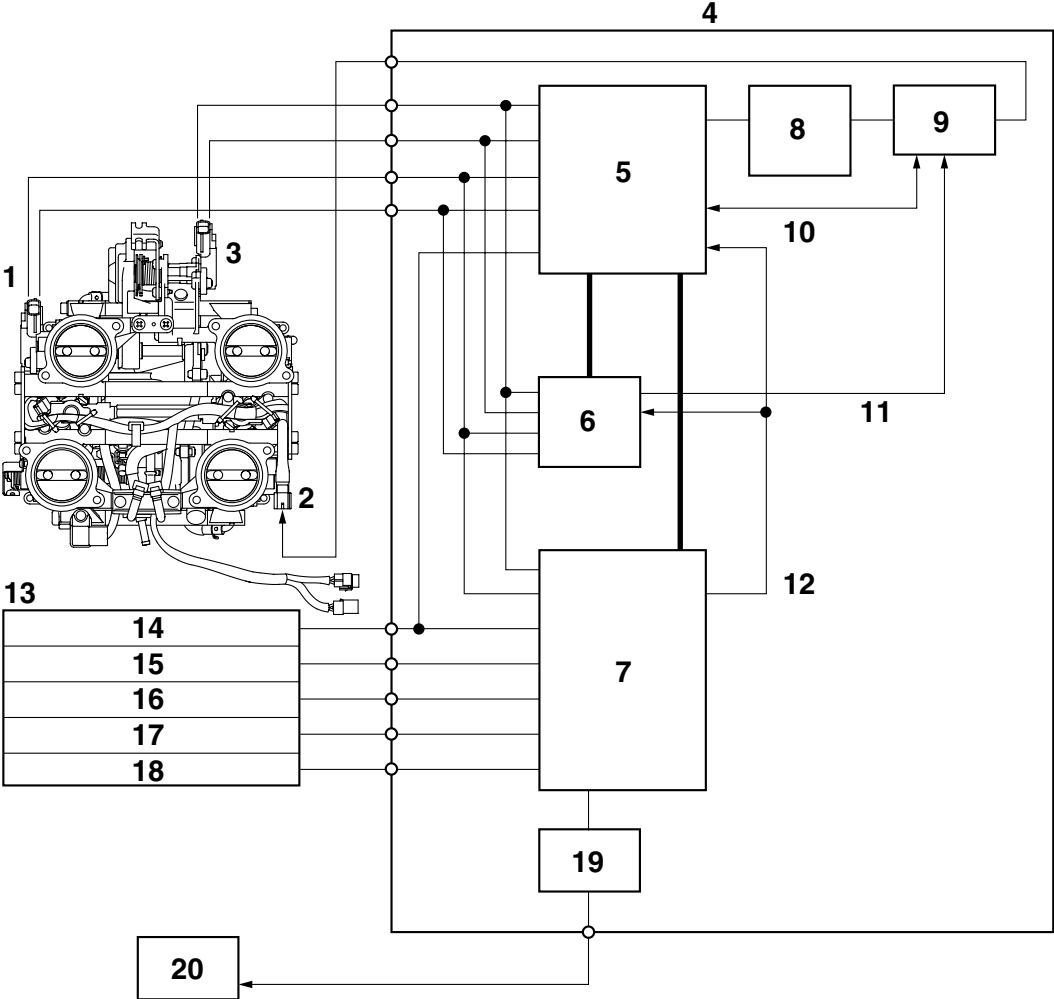

- 1. Throttle position sensor
- 2. Throttle servo motor
- 3. Accelerator position sensor
- 4. ECU (engine control unit)
- 5. ETV main CPU (32 bit)
- 6. ETV sub CPU (16 bit)
- 7. FI CPU (32 bit)
- 8. Throttle servo motor driver
- 9. Throttle servo motor driver operation sensing/shut off circuit
- 10. Throttle servo motor driver operation sensing feedback/emergency stop
- 11. Emergency stop
- 12. Engine revolution (pulse signal)
- 13. Sensor input
- 14. Neutral switch
- 15. Crankshaft position sensor
- 16. Speed sensor
- 17. Coolant temperature sensor
- 18. Atmospheric pressure sensor
- 19. Intake funnel servo motor driver
- 20. Intake funnel servo motor

EAS2S31097

INSTRUMENT FUNCTIONS

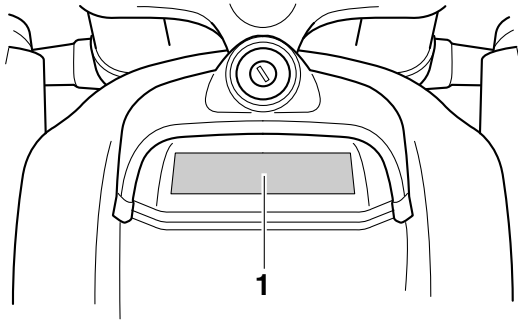

1. Multi-function display

EWA2S31030

WARNING

Be sure to stop the vehicle before making any setting changes to the multi-function display. Changing settings while riding can distract the operator and increase the risk of an accident.

A “SELECT” button and a “RESET” button are located on the handlebar holder. These buttons allow you to control or change the settings in the multi-function display.

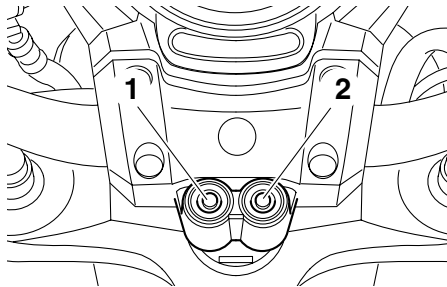

1. “SELECT” button
2. “RESET” button

The multi-function display is set to the Normal mode every time the key is turned to “ON”.

Normal mode

The following functions are available in the Normal mode:

- an odometer (which shows the total distance traveled)
- a clock
- two tripmeters (which show the distance traveled since they were last set to zero)
- a fuel reserve tripmeter (which shows the distance traveled since the fuel level warning indicator started flashing)
- a fuel meter

- a transmission gear indicator
- a coolant temperature display
- a self-diagnosis device

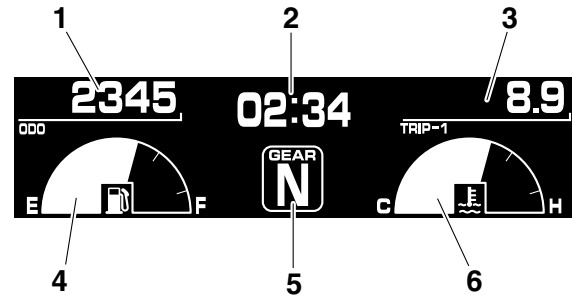

1. Odometer
2. Clock
3. Trip/Fuel
4. Fuel meter
5. Transmission gear display
6. Coolant temperature display

TIP

The speedometer and odometer/tripmeter displays can be switched between miles and kilometers. To switch the speedometer and odometer/tripmeter displays, press “SELECT” for at least two seconds.

Tripmeters

Turn the key to “ON”. Push “SELECT” to switch the display between the tripmeters “TRIP-1” and “TRIP-2” in the following order.

TRIP-1 → TRIP-2 → TRIP-1

When the fuel amount in the fuel tank decreases to 3.9 L (1.03 US gal, 0.86 Imp.gal), the fuel warning indicator starts flashing, and the tripmeter automatically changes to the fuel reserve tripmeter “TRIP-F” and starts counting the distance traveled from that point. In that case, push “SELECT” to switch the display between the various tripmeters in the following order:

TRIP-F → TRIP-1 → TRIP-2 → TRIP-F

To reset a tripmeter, select it by pushing “SELECT”, and then push “RESET” for at least one second. If you do not reset the fuel reserve tripmeter manually, it resets itself automatically and the display returns to the prior meter after refueling and traveling 5 km (3 mi).

Select mode

The various functions of this multi-function display are adjusted in the Select mode.

TIP

- The transmission must be in neutral to change settings in this mode.
- Shifting the transmission into gear saves all settings made, then cancels the Select mode and displays the Normal mode in all screens.
- Depending on the screen, pushing “RESET” saves settings or cancels the Select mode to display the Normal mode.

Push and hold “SELECT” and “RESET” for at least two seconds to enter the Select mode.

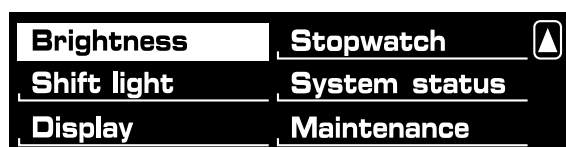

The following items can be set/adjusted in this mode:

- brightness
- shift timing indicator light
- clock
- stopwatch
- countdown clock
- system status
- maintenance counters

TIP

To return to the Normal mode, push “SELECT” to scroll to “▲”, then push “RESET”.

Adjusting the brightness

This function allows you to adjust the brightness of the tachometer unit panel (“Meter panel”), the tachometer needle (“Needle”), and the speedometer and multi-function displays (“Display”) to suit the outside lighting conditions.

1. Push “SELECT” to highlight “Brightness”.



2. Push “RESET”, then push “SELECT” to scroll through the functions and to highlight an item.

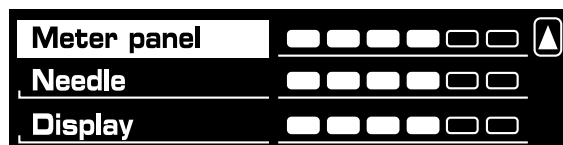

3. Push “RESET”; the brightness level segments for the selected item starts flashing.
4. Push “SELECT” to highlight the desired brightness level.
5. Push “RESET” to set the brightness level.
6. Push “SELECT” to scroll to “▲”, then push “RESET” to return to the previous menu.

Selecting the shift timing indicator light settings

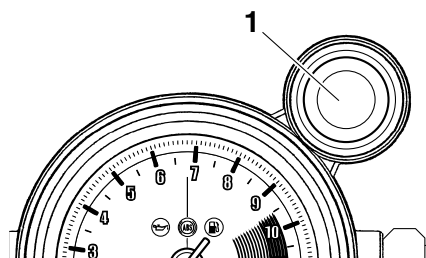

1. Shift timing indicator light

This function allows you to choose whether or not the shift timing indicator light is activated and whether it flashes or stays on when activated.

1. Push “SELECT” to highlight “Shift light”.



2. Push "RESET".
3. Push "SELECT" to highlight "Operation selection".

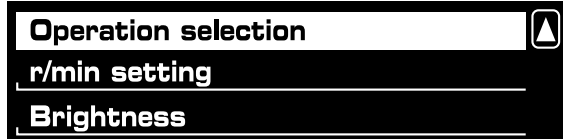

4. Push "RESET".
Push "SELECT" and highlight "On" to activate the indicator light; the indicator light comes on and stays on when activated.



Push "SELECT" and highlight "Flash" to activate the indicator light; the indicator light flashes when activated.



Push "SELECT" and highlight "Off" to deactivate the indicator light; the indicator light neither comes on nor flashes.

TIP

The indicator light flashes once every two seconds to show that it has been deactivated. The indicator light goes off after this menu is exited.

5. Push "SELECT" to scroll to "▲", then push "RESET" to return to the previous menu.

Setting the r/min in relation to the shift timing indicator light

This function allows you to select the engine speed at which the indicator light is activated and deactivated. All gears can be set to the same activation/deactivation r/min or the gears can be set individually.

Push "SELECT" to highlight "r/min setting", then push "RESET".

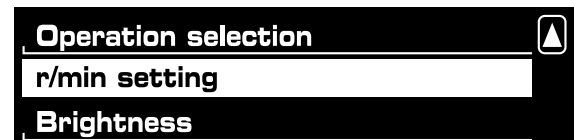

TIP

The shift timing indicator light can be set to activate and deactivate between 3000 r/min and 11000 r/min in increments of 500 r/min.

To set all gears to the same r/min:

1. Push “SELECT” to highlight “All”.



2. Push “RESET”; “On” is displayed.



3. Push “RESET” and the r/min digits start flashing.
4. Push “SELECT” to highlight the engine speed at which the shift timing indicator light is activated.
5. Push “RESET” to set the selected engine speed. “Off” is highlighted and the r/min digits start flashing.
6. Push “SELECT” to highlight the engine speed at which the shift timing indicator light is deactivated.
7. Push “RESET” to set the selected engine speed.
8. Push “RESET” again to return to the previous menu.

To set individual gear r/min:

1. Push “SELECT” to highlight gears from “1st” through “5th”, then push “RESET”.



2. Push “RESET” and the r/min digits for the highlighted gear start flashing, then perform steps 4-8 under “To set all gears to the same r/min:” in order to set the r/min for the individual gears.

TIP

After setting r/min for individual gears, if “All” is chosen, all previously set r/min for individual gears return to the default settings of 9000 (activation) and 11000 (deactivation).

3. Push “SELECT” to scroll to “”, then push “RESET” to return to the previous menu.

Setting the shift timing indicator light brightness

This function allows you to adjust the brightness of the shift timing indicator light.

1. Push “SELECT” to highlight “Brightness”.



2. Push “RESET” and the brightness level segments start flashing.

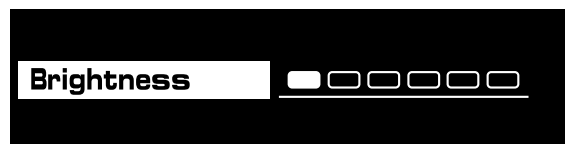

3. Push “SELECT” to highlight the desired brightness level.
4. Push “RESET” to set the selected brightness level.
5. Push “RESET” to return to the previous menu.
6. Push “SELECT” to scroll to “”, then push “RESET”. This allows you to select another item in the menu.

Setting the clock

1. Push “SELECT” to highlight “Display”.



2. Push “RESET”.

3. Push “SELECT” to highlight “All reset”.

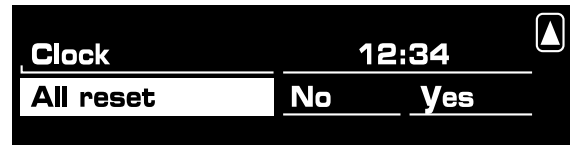

2. Push “RESET”; the following screen is displayed.

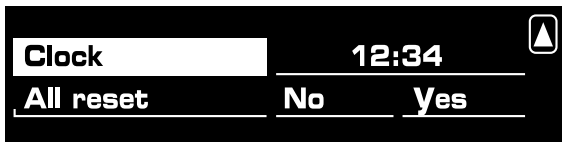

4. Push “RESET”, then push “SELECT” to highlight “Yes”.

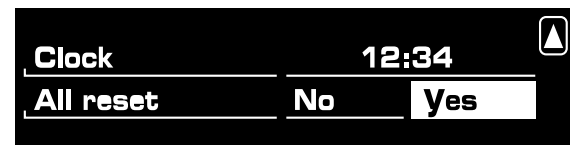

3. Push “RESET” and the hour digits start flashing.
4. Push “SELECT” to increment the hours.
5. Push “RESET”, and the minute digits start flashing.
6. Push “SELECT” to increment the minutes.
7. Push “RESET” to start the clock.
8. Push “RESET” again to return to the previous menu.

Resetting all the brightness and shift timing indicator light functions:

This resets ALL settings made to the brightness and shift timing indicator light functions.

1. Push “SELECT” to highlight “Display”.

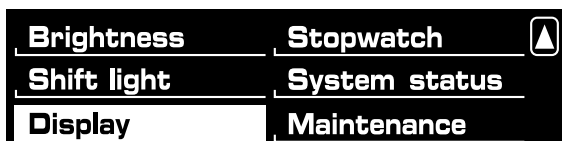

5. Push “RESET” to reset the brightness and shift timing light indicator values to the factory setting. The display returns to the Normal mode.

TIP

To perform further multi-function display settings, enter the Select mode again by pushing and holding “SELECT” and “RESET” for at least three seconds.

Using the stopwatch

The stopwatch can be activated as follows.

1. Push “SELECT” to highlight “Stopwatch”.

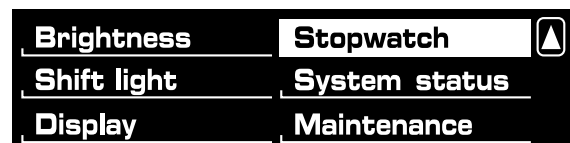

2. Push "RESET".
3. Push "SELECT" to highlight "Stopwatch".



1. Push "SELECT" to highlight "Stopwatch".
2. Push "RESET".
3. Push "SELECT" to highlight "Countdown".



4. Push "RESET".
The multi-function display changes to the Normal mode and the stopwatch is displayed in place of the clock.



5. Push "SELECT" to start the stopwatch.
6. Push "SELECT" or the start switch "⊞" to stop the stopwatch.
7. Push "RESET" to reset the stopwatch.

TIP

- If neither "SELECT" or "RESET" are pushed for one minute, the screen automatically changes to the Normal mode.
- Pushing "RESET" for at least two seconds changes the screen to the Normal mode.
- To perform further multi-function display settings, enter the Select mode again by pushing and holding "SELECT" and "RESET" for at least three seconds.

Using the countdown clock:

The countdown clock can be activated as follows.

4. Push "RESET". The multi-function display changes to the Normal mode, the stopwatch is displayed in place of the clock, and the transmission gear indicator changes to the countdown clock.
5. Push "SELECT" or shift into gear and the countdown clock starts counting down from "5". Simultaneously, the shift timing indicator flashes according to the number displayed (i.e., when "5" is displayed, the indicator flashes five times, when "4" is displayed, the indicator flashes four times, etc.). The stopwatch starts counting when the countdown clock finishes counting.
6. Push "SELECT" or push the start switch "⊞" to stop the countdown clock.
7. Push "RESET" to reset the countdown clock and stopwatch.
8. Push "RESET" to reset the countdown clock, and then repeat steps 5–6, OR push "RESET" again for at least two seconds to enter the Normal mode.

TIP

To perform further multi-function display settings, **be sure the transmission is in neutral**, then enter the Select mode again by pushing and holding "SELECT" and "RESET" for at least three seconds.

Checking and resetting the system status

The status/readings of the following items are displayed, and the tripmeters can be reset.

- tripmeters and odometer
- fuel consumption
- air intake temperature
- throttle opening position

TIP

- The "System status" menu cannot be entered if the fuel level warning light or coolant temperature warning light is on.

- If, when the engine is running while the system status menu is displayed, the fuel level warning light or coolant temperature warning light comes on, the Normal mode is automatically displayed.

- Push “SELECT” to highlight “System status”, then push “RESET”.

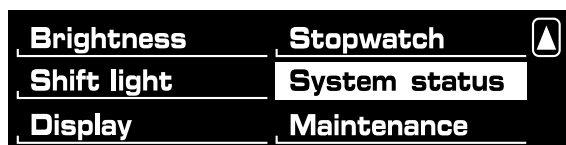

- Push “SELECT” to highlight “Yes”, then push “RESET”. (Highlighting “No” and pushing “RESET” returns to the previous menu.)

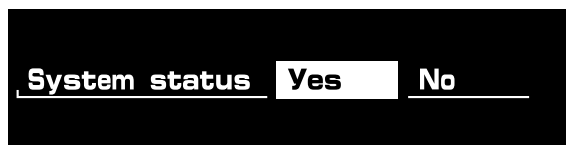

The display changes to the status screen.

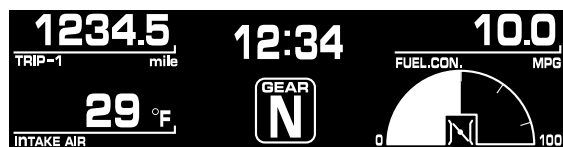

Push “SELECT” and the various tripmeters and the odometer are displayed in the following order:

(TRIP-F) → TRIP-1 → TRIP-2 → ODO → (TRIP-F)

Push “RESET” to reset a tripmeter.

TIP

- Push “SELECT” for at least two seconds to switch between miles and kilometers.

- Pushing “RESET” displays the Normal mode for five seconds. Pushing “SELECT” and “RESET” for at least three seconds, changes the display to the Normal mode.

- To perform further multi-function display settings, enter the Select mode again by pushing and holding “SELECT” and “RESET” for at least three seconds.

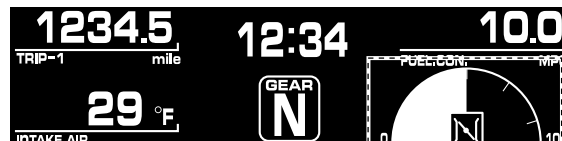

Resetting the maintenance counters

This function allows you to reset the maintenance counters for the tires, the engine oil, and an item of your choice.

- Push “SELECT” to highlight “Maintenance”, then push “RESET”.



- Push “SELECT” to highlight the item to reset.



- Push “RESET” to reset the item.

TIP

The bottom area was left blank for another item the rider cares to check the distance of since it has been changed, replaced or checked (i.e., air filter element, engine parts, etc.).



4. Push “SELECT” to scroll to “▲”.
5. Push “RESET” to return to the previous menu.

Self-diagnosis device

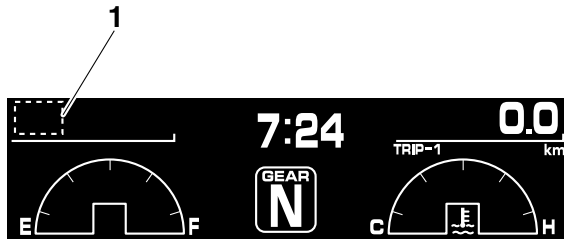

1. Fault code display

This model is equipped with a self-diagnosis device for various electrical circuits.

If a problem is detected in any of those circuits, the engine trouble warning light comes on and the display indicates a two-digit fault code.

ECA2S31064

NOTICE

If the display indicates an fault code, the vehicle should be checked as soon as possible in order to avoid engine damage.

If the display indicates any fault codes, note the code number, and check the vehicle.

Refer to “FUEL INJECTION SYSTEM” on page 8-33.

EAS20180

IMPORTANT INFORMATION

EAS20190

PREPARATION FOR REMOVAL AND DISASSEMBLY

1. Before removal and disassembly, remove all dirt, mud, dust and foreign material.

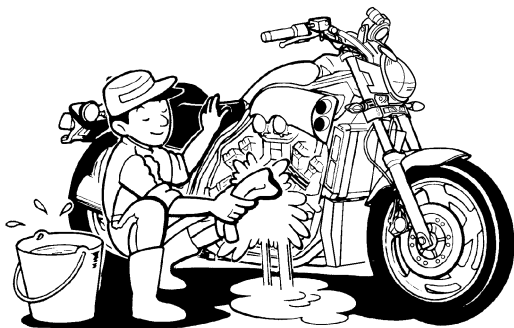

2. Use only the proper tools and cleaning equipment.

Refer to "SPECIAL TOOLS" on page 1-37.

3. When disassembling, always keep mated parts together. This includes gears, cylinders, pistons and other parts that have been "mated" through normal wear. Mated parts must always be reused or replaced as an assembly.

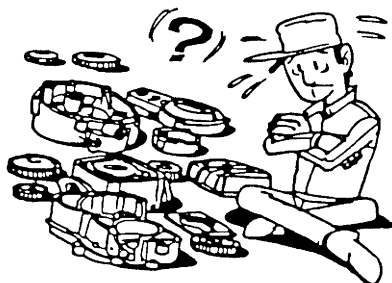

4. During disassembly, clean all of the parts and place them in trays in the order of disassembly. This will speed up assembly and allow for the correct installation of all parts.
5. Keep all parts away from any source of fire.

EAS20200

REPLACEMENT PARTS

Use only genuine Yamaha parts for all replacements. Use oil and grease recommended by Yamaha for all lubrication jobs. Other brands may be similar in function and appearance, but inferior in quality.

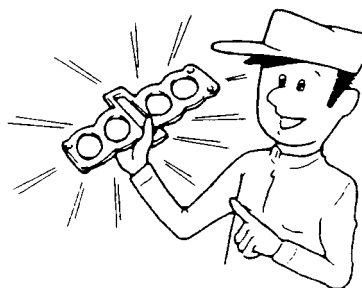

EAS20210

GASKETS, OIL SEALS AND O-RINGS

1. When overhauling the engine, replace all gaskets, seals and O-rings. All gasket surfaces, oil seal lips and O-rings must be cleaned.
2. During reassembly, properly oil all mating parts and bearings and lubricate the oil seal lips with grease.

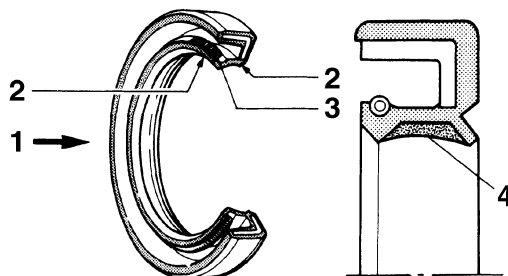

1. Oil
2. Lip
3. Spring
4. Grease

EAS20220

LOCK WASHERS/PLATES AND COTTER PINS

After removal, replace all lock washers/plates "1" and cotter pins. After the bolt or nut has been tightened to specification, bend the lock tabs along a flat of the bolt or nut.

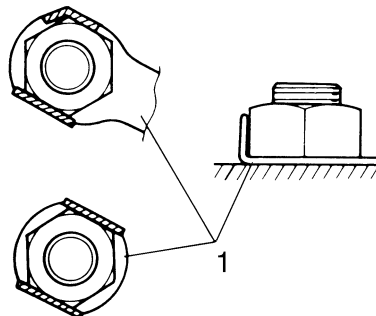

EAS20230

BEARINGS AND OIL SEALS

Install bearings "1" and oil seals "2" so that the manufacturer marks or numbers are visible. When installing oil seals, lubricate the oil seal lips with a light coat of lithium-soap-based grease. Oil bearings liberally when installing, if appropriate.

ECA13300

NOTICE

Do not spin the bearing with compressed air because this will damage the bearing surfaces.

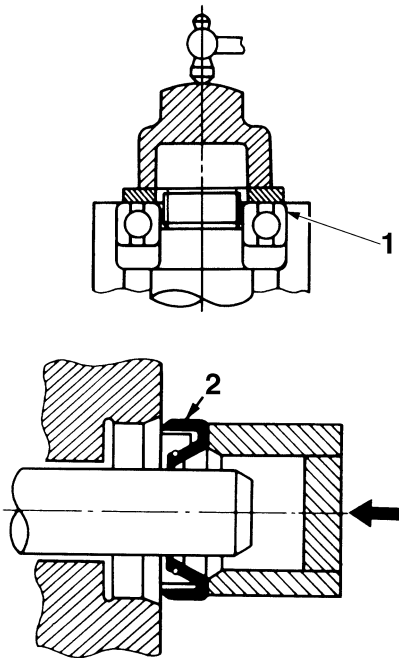

EAS20240

CIRCLIPS

Before reassembly, check all circlips carefully and replace damaged or distorted circlips. Always replace piston pin clips after one use. When installing a circlip "1", make sure the sharp-edged corner "2" is positioned opposite the thrust "3" that the circlip receives.

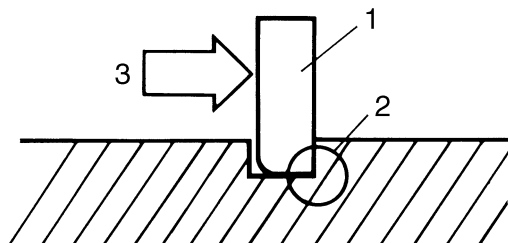

CHECKING THE CONNECTIONS

EAS20250

CHECKING THE CONNECTIONS

Check the leads, couplers, and connectors for stains, rust, moisture, etc.

1. Disconnect:

- Lead
- Coupler
- Connector

2. Check:

- Lead
- Coupler
- Connector

Moisture → Dry with an air blower.

Rust/stains → Connect and disconnect several times.

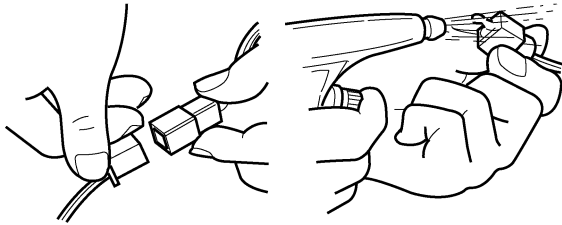

3. Check:

- All connections

Loose connection → Connect properly.

TIP

If the pin "1" on the terminal is flattened, bend it up.

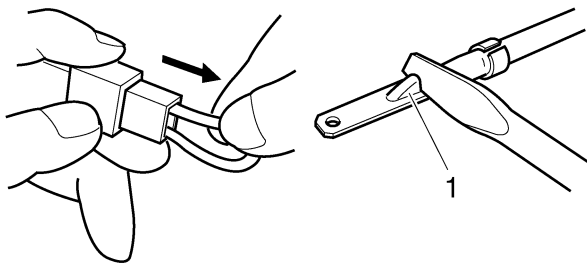

4. Connect:

- Lead
- Coupler
- Connector

TIP

Make sure all connections are tight.

5. Check:

- Continuity
(with the pocket tester)



Pocket tester
90890-03112
Analog pocket tester
YU-03112-C

TIP

- If there is no continuity, clean the terminals.
- When checking the wire harness, perform steps (1) to (3).
- As a quick remedy, use a contact revitalizer available at most part stores.

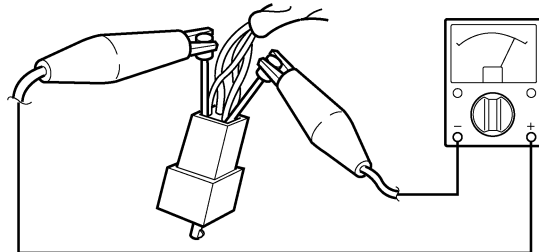
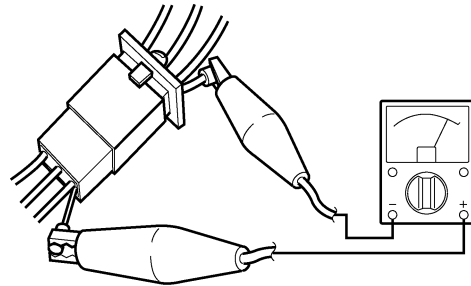





EAS20260

SPECIAL TOOLS

The following special tools are necessary for complete and accurate tune-up and assembly. Use only the appropriate special tools as this will help prevent damage caused by the use of inappropriate tools or improvised techniques. Special tools, part numbers or both may differ depending on the country. When placing an order, refer to the list provided below to avoid any mistakes.

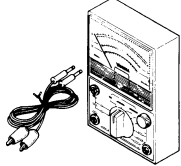
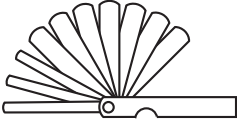
TIP

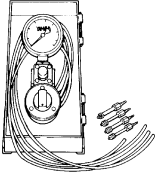
- For U.S.A. and Canada, use part number starting with “YM-”, “YU-”, or “ACC-”.
- For others, use part number starting with “90890-”.

Tool name/Tool No.	Illustration	Reference pages
Test coupler adapter 90890-03149		1-19, 4-60, 4-61
Pocket tester 90890-03112 Analog pocket tester YU-03112-C		1-36, 8-114, 8-115, 8-123, 8-124, 8-125, 8-129, 8-130, 8-131, 8-132, 8-133, 8-134, 8-135, 8-137, 8-138, 8-139, 8-140
Thickness gauge 90890-03180 Feeler gauge set YU-26900-9		3-4, 3-5, 5-57
Valve lapper 90890-04101 Valve lapping tool YM-A8998		3-5
Vacuum gauge 90890-03094 Carburetor synchronizer YU-44456	90890-03094  YU-44456 	3-7

SPECIAL TOOLS

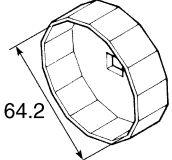
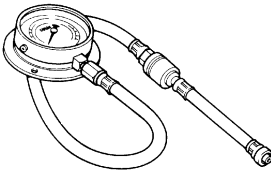
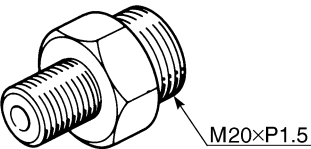
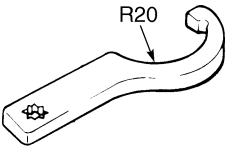
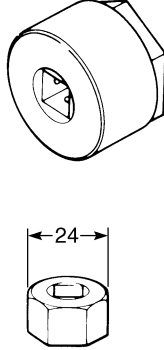
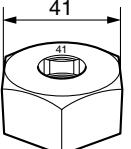
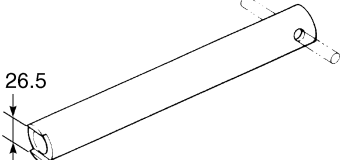
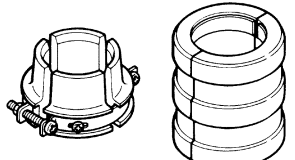
Tool name/Tool No.	Illustration	Reference pages
Oil filter wrench 90890-01426 YU-38411		3-11
Oil pressure gauge set 90890-03120		3-12
Oil pressure adapter B 90890-03124		3-12
Steering nut wrench 90890-01403 Exhaust flange nut wrench YU-A9472		3-27, 4-81
Damper rod holder (24 mm) 90890-01328 YM-01328	90890-01328  YM-01328	4-23, 4-27, 4-48, 4-50
Hexagon wrench (41) 90890-01525 YM-01525		4-24, 4-25
Damper rod holder 90890-01447 YM-01447		4-73, 4-74
Fork seal driver 90890-01502 YM-A0948		4-74, 4-75

SPECIAL TOOLS

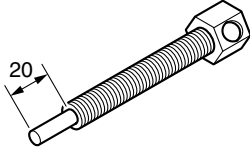
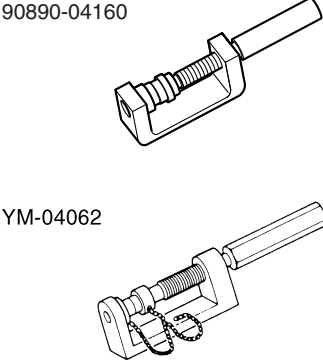
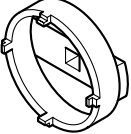
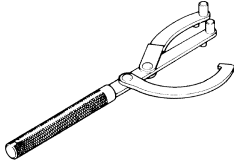
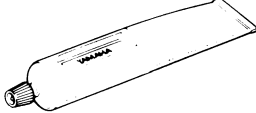
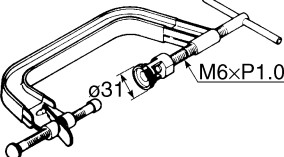
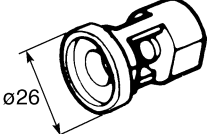
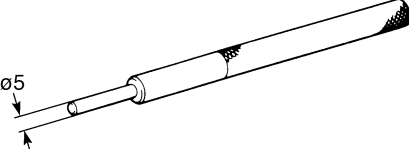
Tool name/Tool No.	Illustration	Reference pages
Ring gear fix bolt (M14) 90890-01548 YM-01548		4-97
Universal joint holder 90890-04160 YM-04062		4-98, 4-102, 5-109, 5-111
Bearing retainer wrench 90890-04159 Pinion bearing retainer & remover YM-04159		4-99, 4-102
Rotor holding tool 90890-01235 Universal magneto & rotor holder YU-01235		5-14, 5-17, 5-18, 5-21
Yamaha bond No. 1215 90890-85505 (Three bond No.1215®)		5-24, 5-42, 5-77
Valve spring compressor 90890-04019 YM-04019		5-30, 5-35
Valve spring compressor attachment 90890-01243 Valve spring compressor adapter (26 mm) YM-01253-1		5-30, 5-35
Valve guide remover (ø5) 90890-04097 Valve guide remover (5.0 mm) YM-04097		5-32

SPECIAL TOOLS

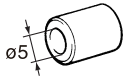
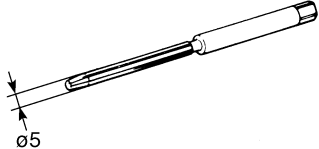
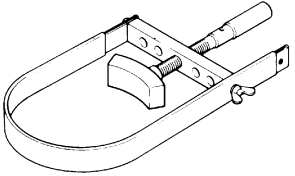
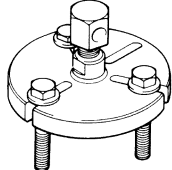
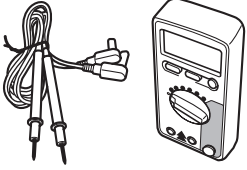
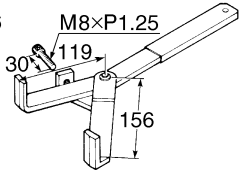
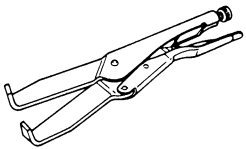
Tool name/Tool No.	Illustration	Reference pages
Valve guide installer (ø5) 90890-04098 Valve guide installer (5.0 mm) YM-04098		5-32
Valve guide reamer (ø5) 90890-04099 Valve guide reamer (5.0 mm) YM-04099		5-32
Sheave holder 90890-01701 Primary clutch holder YS-01880-A		5-40, 5-41, 5-42
Flywheel puller 90890-01362 Heavy duty puller YU-33270-B		5-40
Digital circuit tester 90890-03174 Model 88 Multimeter with tachometer YU-A1927		5-46
Universal clutch holder 90890-04086 YM-91042	<p data-bbox="763 1239 893 1260">90890-04086</p>  <p data-bbox="763 1438 876 1459">YM-91042</p> 	5-56, 5-59

SPECIAL TOOLS

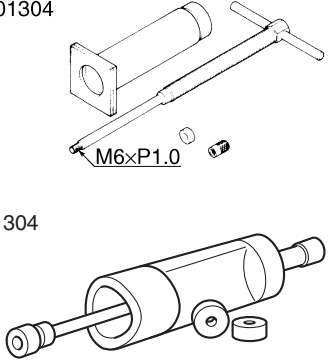
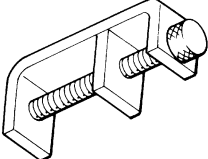
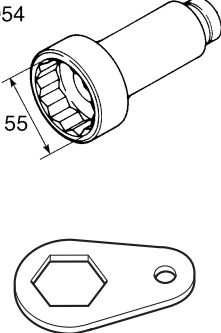
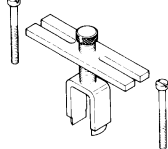
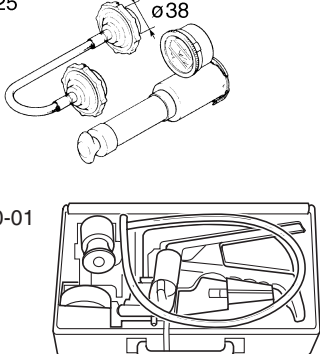
Tool name/Tool No.	Illustration	Reference pages
Piston pin puller set 90890-01304 Piston pin puller YU-01304	90890-01304  YU-01304	5-82
Damper spring compressor 90890-04090		5-109, 5-111
Middle drive shaft nut wrench (55 mm) 90890-04054 Offset wrench 55 mm YM-04054	90890-04054  YM-04054	5-110
Middle gear backlash tool 90890-04080		5-113
Radiator cap tester 90890-01325 Radiator pressure tester YU-24460-01	90890-01325  YU-24460-01	6-4

SPECIAL TOOLS

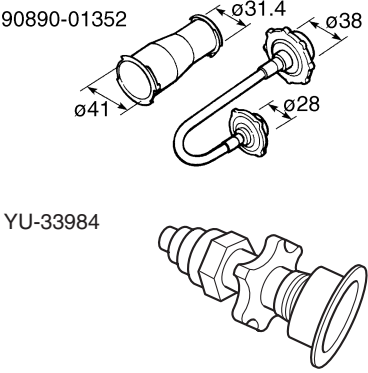
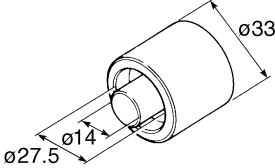
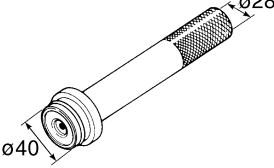
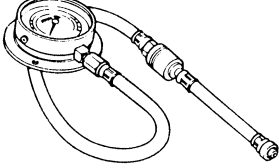
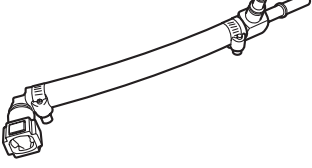
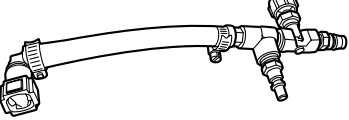
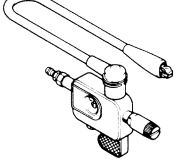
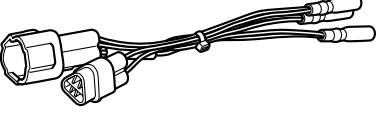
Tool name/Tool No.	Illustration	Reference pages
Radiator cap tester adapter 90890-01352 Radiator pressure tester adapter YU-33984		6-4
Mechanical seal installer 90890-04132 Water pump seal installer YM-33221-A		6-13
Middle driven shaft bearing driver 90890-04058 Bearing driver 40 mm YM-04058		6-13
Pressure gauge 90890-03153 YU-03153		7-5, 7-14
Fuel pressure adapter 90890-03176 YM-03176		7-5
Fuel injector pressure adapter 90890-03210 YU-03210		7-14
Ignition checker 90890-06754 Opama pet-4000 spark checker YM-34487		8-132
Test harness-speed sensor (3P) 90890-03208 YU-03208		8-139

SPECIFICATIONS

GENERAL SPECIFICATIONS	2-1
ENGINE SPECIFICATIONS	2-2
CHASSIS SPECIFICATIONS	2-10
ELECTRICAL SPECIFICATIONS	2-13
TIGHTENING TORQUES	2-16
GENERAL TIGHTENING TORQUE SPECIFICATIONS.....	2-16
ENGINE TIGHTENING TORQUES	2-17
CHASSIS TIGHTENING TORQUES.....	2-23
LUBRICATION POINTS AND LUBRICANT TYPES	2-29
ENGINE.....	2-29
CHASSIS.....	2-31
LUBRICATION SYSTEM CHART AND DIAGRAMS.....	2-33
ENGINE OIL LUBRICATION CHART	2-33
LUBRICATION DIAGRAMS	2-35
COOLING SYSTEM DIAGRAMS	2-43
CABLE ROUTING	2-47

GENERAL SPECIFICATIONS

EAS20280

GENERAL SPECIFICATIONS

Model

Model	2S31 (USA) 2S32 (California)
-------	---------------------------------

Dimensions

Overall length	2395 mm (94.3 in)
Overall width	820 mm (32.3 in)
Overall height	1190 mm (46.9 in)
Seat height	775 mm (30.5 in)
Wheelbase	1700 mm (66.9 in)
Ground clearance	140 mm (5.51 in)
Minimum turning radius	3500 mm (137.8 in)

Weight

With oil and fuel	310.0 kg (683 lb) (USA) 311.0 kg (686 lb) (California)
Maximum load	190 kg (419 lb) (USA) 189 kg (417 lb) (California)

ENGINE SPECIFICATIONS

EAS20290

ENGINE SPECIFICATIONS

Engine

Engine type	Liquid cooled 4-stroke, DOHC
Displacement	1679.0 cm ³
Cylinder arrangement	V-type 4-cylinder
Bore × stroke	90.0 × 66.0 mm (3.54 × 2.60 in)
Compression ratio	11.30 :1
Minimum–maximum	1250–1650 kPa (12.5–16.5 kgf/cm ² , 177.8–234.7 psi)
Starting system	Electric starter

Fuel

Recommended fuel	Premium unleaded gasoline only
Fuel tank capacity	15.0 L (3.96 US gal, 3.30 Imp.gal)
Fuel reserve amount	3.9 L (1.03 US gal, 0.86 Imp.gal)

Engine oil

Lubrication system	Wet sump
Type	YAMALUBE 4 10W-40 or 20W-50, SAE 10W-40 or SAE 20W-50
Recommended engine oil grade	API service SG type or higher, JASO standard MA
Engine oil quantity	
Total amount	5.90 L (6.24 US qt, 5.19 Imp.qt)
Without oil filter cartridge replacement	4.30 L (4.55 US qt, 3.78 Imp.qt)
With oil filter cartridge replacement	4.70 L (4.97 US qt, 4.14 Imp.qt)
Oil pressure	50.0 kPa/1000 r/min (0.50 kgf/cm ² /1000 r/min, 7.3 psi/1000 r/min)

Final gear oil

Type	Shaft drive gear oil (Part No.: 9079E-SH001–00)
Quantity	0.30 L (0.32 US qt, 0.26 Imp.qt)

Oil filter

Oil filter type	Paper
-----------------	-------

Oil pump

Oil pump type	Trochoid
Inner-rotor-to-outer-rotor-tip clearance	Less than 0.120 mm (0.0047 in)
Limit	0.20 mm (0.0079 in)
Outer-rotor-to-oil-pump-housing clearance	0.090–0.190 mm (0.0035–0.0075 in)
Limit	0.26 mm (0.0102 in)
Oil-pump-housing-to-inner-and-outer-rotor clearance	0.06–0.11 mm (0.0024–0.0043 in)
Limit	0.18 mm (0.0071 in)
Relief valve operating pressure	660.0–740.0 kPa (6.60–7.40 kgf/cm ² , 95.7–107.3 psi)

Cooling system

Radiator capacity (including all routes)	3.75 L (3.96 US qt, 3.30 Imp.qt)
--	----------------------------------

ENGINE SPECIFICATIONS

Coolant reservoir capacity (up to the maximum level mark)	0.27 L (0.29 US qt, 0.24 Imp.qt)
Radiator cap opening pressure	107.9–137.3 kPa (1.08–1.37 kgf/cm ² , 15.6–19.9 psi)
Radiator core	
Width	400.0 mm (15.75 in)
Height	200.2 mm (7.88 in)
Depth	24.0 mm (0.94 in)
Sub radiator core	
Width	260.0 mm (10.24 in)
Height	200.2 mm (7.88 in)
Depth	24.0 mm (0.94 in)
Water pump	
Water pump type	Single suction centrifugal pump
Reduction ratio	27/21 (1.286)

Spark plug (s)

Manufacturer/model	NGK/CR9EIA
Manufacturer/model	DENSO/IU27D
Spark plug gap	0.8–0.9 mm (0.031–0.035 in)

Cylinder head

Volume	28.10–29.00 cm ³ (1.71–1.77 cu.in)
Warpage limit	0.03 mm (0.0012 in)

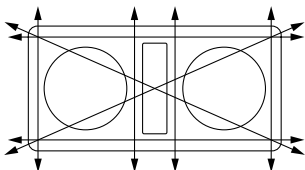

Camshaft

Drive system	Chain/gear drive (center)
Camshaft cap inside diameter	22.000–22.021 mm (0.8661–0.8670 in)
Camshaft journal diameter	21.959–21.972 mm (0.8645–0.8650 in)
Camshaft-journal-to-camshaft-cap clearance	0.028–0.062 mm (0.0011–0.0024 in)
Camshaft lobe dimensions	
Intake A	32.850–32.950 mm (1.2933–1.2972 in)
Limit	32.750 mm (1.2894 in)
Intake B	24.131–24.231 mm (0.9500–0.9540 in)
Limit	24.031 mm (0.9461 in)
Exhaust A	32.850–32.950 mm (1.2933–1.2972 in)
Limit	32.750 mm (1.2894 in)

Exhaust B
Limit

24.131–24.231 mm (0.9500–0.9540 in)
24.031 mm (0.9461 in)

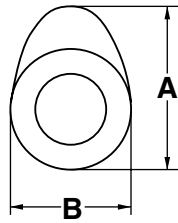

Camshaft runout limit

0.030 mm (0.0012 in)

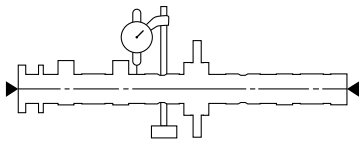

Timing chain

Tensioning system

Automatic

Valve, valve seat, valve guide

Valve clearance (cold)

Intake

0.10–0.17 mm (0.0039–0.0067 in)

Exhaust

0.22–0.29 mm (0.0087–0.0114 in)

Valve dimensions

Valve head diameter A (intake)

33.90–34.10 mm (1.3346–1.3425 in)

Valve head diameter A (exhaust)

29.90–30.10 mm (1.1772–1.1850 in)

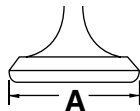

Valve face width B (intake)

1.200–3.100 mm (0.0472–0.1220 in)

Valve face width B (exhaust)

1.500–2.700 mm (0.0591–0.1063 in)

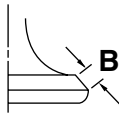

Valve seat width C (intake)

1.10–1.30 mm (0.0433–0.0512 in)

Limit

1.6 mm (0.06 in)

Valve seat width C (exhaust)

1.10–1.30 mm (0.0433–0.0512 in)

Limit

1.6 mm (0.06 in)

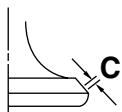

Valve margin thickness D (intake)

1.00 mm (0.0394 in)

ENGINE SPECIFICATIONS

Valve margin thickness D (exhaust) 1.00 mm (0.0394 in)

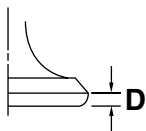

Valve stem diameter (intake)	4.975–4.990 mm (0.1959–0.1965 in)
Limit	4.945 mm (0.1947 in)
Valve stem diameter (exhaust)	4.960–4.975 mm (0.1953–0.1959 in)
Limit	4.930 mm (0.1941 in)
Valve guide inside diameter (intake)	5.000–5.012 mm (0.1969–0.1973 in)
Limit	5.050 mm (0.1988 in)
Valve guide inside diameter (exhaust)	5.000–5.012 mm (0.1969–0.1973 in)
Limit	5.050 mm (0.1988 in)
Valve-stem-to-valve-guide clearance (intake)	0.010–0.037 mm (0.0004–0.0015 in)
Limit	0.080 mm (0.0032 in)
Valve-stem-to-valve-guide clearance (exhaust)	0.025–0.052 mm (0.0010–0.0020 in)
Limit	0.100 mm (0.0039 in)
Valve stem runout	0.010 mm (0.0004 in)

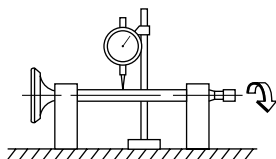

Valve spring

Outer spring	
Free length (intake)	40.78 mm (1.61 in)
Limit	38.74 mm (1.53 in)
Free length (exhaust)	40.78 mm (1.61 in)
Limit	38.74 mm (1.53 in)
Installed length (intake)	33.88 mm (1.33 in)
Installed length (exhaust)	33.88 mm (1.33 in)
Spring rate K1 (intake)	29.00 N/mm (2.96 kgf/mm, 165.59 lb/in)
Spring rate K2 (intake)	39.01 N/mm (3.98 kgf/mm, 222.75 lb/in)
Spring rate K1 (exhaust)	29.00 N/mm (2.96 kgf/mm, 165.59 lb/in)
Spring rate K2 (exhaust)	39.01 N/mm (3.98 kgf/mm, 222.75 lb/in)
Installed compression spring force (intake)	186.00–214.00 N (18.97–21.82 kgf, 41.81–48.11 lbf)
Installed compression spring force (exhaust)	186.00–214.00 N (18.97–21.82 kgf, 41.81–48.11 lbf)
Spring tilt (intake)	2.5°/1.8 mm
Spring tilt (exhaust)	2.5°/1.8 mm

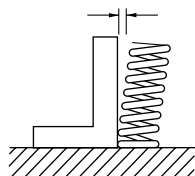

Winding direction (intake) Clockwise
Winding direction (exhaust) Clockwise

ENGINE SPECIFICATIONS

Cylinder

Bore	90.000–90.010 mm (3.5433–3.5437 in)
Taper limit	0.050 mm (0.0020 in)
Out of round limit	0.050 mm (0.0020 in)

Piston

Piston-to-cylinder clearance Limit	0.025–0.050 mm (0.0010–0.0020 in) 0.10 mm (0.0039 in)
Diameter D	89.960–89.975 mm (3.5417–3.5423 in)
Height H	10.0 mm (0.39 in)

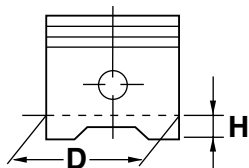

Offset	0.00 mm (0.0000 in)
Piston pin bore inside diameter Limit	19.004–19.015 mm (0.7482–0.7486 in) 19.045 mm (0.7498 in)
Piston pin outside diameter Limit	18.991–19.000 mm (0.7477–0.7480 in) 18.971 mm (0.7469 in)
Piston-pin-to-piston-pin-bore clearance Limit	0.004–0.024 mm (0.0002–0.0009 in) 0.074 mm (0.0029 in)

Piston ring

Top ring	
Ring type	Barrel
Dimensions (B × T)	1.00 × 3.30 mm (0.04 × 0.13 in)

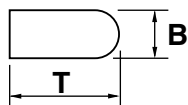

End gap (installed) Limit	0.20–0.35 mm (0.0079–0.0138 in) 0.60 mm (0.0236 in)
Ring side clearance Limit	0.030–0.070 mm (0.0012–0.0028 in) 0.120 mm (0.0047 in)

2nd ring	
Ring type	Taper
Dimensions (B × T)	1.00 × 3.35 mm (0.04 × 0.13 in)

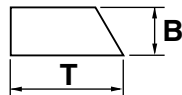

End gap (installed) Limit	0.40–0.55 mm (0.0157–0.0217 in) 0.80 mm (0.0315 in)
Ring side clearance Limit	0.020–0.060 mm (0.0008–0.0024 in) 0.120 mm (0.0047 in)

ENGINE SPECIFICATIONS

Oil ring

Dimensions (B × T)

2.00 × 2.80 mm (0.08 × 0.11 in)

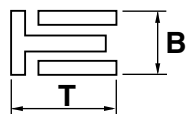

End gap (installed)

0.20–0.50 mm (0.0079–0.0197 in)

Connecting rod

Oil clearance

0.032–0.056 mm (0.0013–0.0022 in)

Bearing color code

1.Blue 2.Black 3.Brown 4.Green

Crankshaft

Width A

83.92–83.97 mm (3.304–3.306 in)

Width B

242.72–243.17 mm (9.56–9.57 in)

Runout limit C

0.030 mm (0.0012 in)

Big end side clearance D

0.320–0.474 mm (0.0126–0.0187 in)

Big end radial clearance E

0.032–0.056 mm (0.0013–0.0022 in)

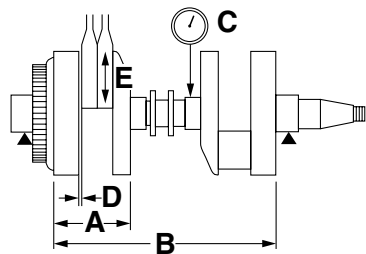

Journal oil clearance

0.032–0.056 mm (0.0013–0.0022 in)

Limit

0.10 mm (0.0039 in)

Bearing color code

1.Blue 2.Black 3.Brown 4.Green 5.Yellow

Balancer

Balancer drive method

Gear

Clutch

Clutch type

Wet, multiple-disc

Clutch release method

Hydraulic inner push

Friction plate thickness

2.92–3.08 mm (0.115–0.121 in)

Wear limit

2.80 mm (0.1102 in)

Plate quantity

10 pcs

Clutch plate thickness

1.90–2.10 mm (0.075–0.083 in)

Plate quantity

9 pcs

Warping limit

0.10 mm (0.0039 in)

Clutch spring height

6.88 mm (0.27 in)

Minimum height

6.38 mm (0.25 in)

Spring quantity

1 pc

Clutch housing thrust clearance

0.100–0.200 mm (0.0039–0.0079 in)

Clutch housing radial clearance

0.001–0.040 mm (0.0000–0.0016 in)

Long clutch push rod bending limit

0.370 mm (0.0146 in)

Transmission

Transmission type

Constant mesh 5-speed

Primary reduction system

Spur gear

ENGINE SPECIFICATIONS

Primary reduction ratio	86/57 (1.509)
Secondary reduction system	Shaft drive
Secondary reduction ratio	22/23 × 29/09 (3.082)
Operation	Left foot operation
Gear ratio	
1st	38/16 (2.375)
2nd	38/21 (1.810)
3rd	35/25 (1.400)
4th	29/26 (1.115)
5th	29/31 (0.935)
Main axle runout limit	0.08 mm (0.0032 in)
Drive axle runout limit	0.08 mm (0.0032 in)

Shifting mechanism	
Shift mechanism type	Shift drum and guide bar
Shift fork guide bar bending limit	0.025 mm (0.0010 in)
Shift fork C thickness	6.26–6.39 mm (0.2465–0.2516 in)
Shift fork L, R thickness	6.76–6.89 mm (0.2261–0.2713 in)
Installed shift rod length	66.5–68.5 mm (2.62–2.70 in)

Air filter	
Air filter element	Oil-coated paper element

Fuel pump	
Pump type	Electrical
Maximum consumption amperage	6.5 A
Output pressure	324.0 kPa (3.24 kgf/cm ² , 47.0 psi)

Fuel injector	
Model/quantity	1240/4

Throttle body	
Type/quantity	EIS48/4
ID mark	2S31 00 (USA) 2S32 00 (California)
Throttle valve size	#50

Throttle position sensor	
Resistance	1.2–2.8 kΩ

Fuel injection sensor	
Crankshaft position sensor resistance	192–288 Ω at 20 °C (68 °F)
Cylinder identification sensor output voltage (ON)	4.8 V
Cylinder identification sensor output voltage (OFF)	0.8 V
Intake air pressure sensor output voltage	3.57–3.71 V
Intake air temperature sensor resistance	290–390 Ω at 80 °C (176 °F)
Atmospheric pressure sensor output voltage	3.57–3.71 V
Coolant temperature sensor resistance	2.45 kΩ at 20 °C (68 °F) 290.0–354.0 Ω at 80 °C (178 °F)

Idling condition	
Engine idling speed	950–1050 r/min
CO%	2.5–3.5%

ENGINE SPECIFICATIONS

Intake vacuum	-26.7 kPa (-200 mmHg, -7.9 inHg)
Water temperature	95.0–105.0 °C (203.00–221.00 °F)
Oil temperature	80.0–90.0 °C (176.00–194.00 °F)
Throttle cable free play	3.0–5.0 mm (0.12–0.20 in)

Air induction system

Solenoid resistance	20–23 Ω at 20 °C (68 °F)
---------------------	---------------------------------

Shaft drive

Middle gear backlash	0.05–0.10 mm (0.002–0.004 in)
Ring-gear-to-thrust-washer clearance	0.15–0.25 mm (0.006–0.010 in)
Final gear backlash	0.1–0.2 mm (0.004–0.008 in)

CHASSIS SPECIFICATIONS

EAS20300

CHASSIS SPECIFICATIONS

Chassis

Frame type	Diamond
Caster angle	31.00°
Trail	148.0 mm (5.83 in)

Front wheel

Wheel type	Cast wheel
Rim size	18M/C × MT3.50
Rim material	Aluminum
Wheel travel	120.0 mm (4.72 in)
Radial wheel runout limit	1.0 mm (0.04 in)
Lateral wheel runout limit	0.5 mm (0.02 in)

Rear wheel

Wheel type	Cast wheel
Rim size	18M/C × MT6.00
Rim material	Aluminum
Wheel travel	110.0 mm (4.33 in)
Radial wheel runout limit	1.0 mm (0.04 in)
Lateral wheel runout limit	0.5 mm (0.02 in)

Front tire

Type	Tubeless
Size	120/70R18M/C 59V
Manufacturer/model	BRIDGESTONE/BT028F
Wear limit (front)	1.0 mm (0.04 in)

Rear tire

Type	Tubeless
Size	200/50R18M/C 76V
Manufacturer/model	BRIDGESTONE/BT028R
Wear limit (rear)	1.0 mm (0.04 in)

Tire air pressure (measured on cold tires)

Loading condition	0–90 kg (0–198 lb)
Front	250 kPa (2.50 kgf/cm ² , 36 psi)
Rear	290 kPa (2.90 kgf/cm ² , 42 psi)
Loading condition	90–190 kg (198–419 lb) (USA)
	90–189 kg (198–417 lb) (California)
Front	250 kPa (2.50 kgf/cm ² , 36 psi)
Rear	290 kPa (2.90 kgf/cm ² , 42 psi)
High-speed riding	
Front	290 kPa (2.90 kgf/cm ² , 42 psi)
Rear	290 kPa (2.90 kgf/cm ² , 42 psi)

Front brake

Type	Dual disc brake
Operation	Right hand operation
Front disc brake	
Disc outside diameter × thickness	320.0 × 5.5 mm (12.60 × 0.22 in)

CHASSIS SPECIFICATIONS

Brake disc thickness limit	5.0 mm (0.20 in)
Brake disc deflection limit	0.10 mm (0.0039 in)
Brake pad lining thickness (inner)	4.5 mm (0.18 in)
Limit	0.8 mm (0.03 in)
Brake pad lining thickness (outer)	4.5 mm (0.18 in)
Limit	0.8 mm (0.03 in)
Master cylinder inside diameter	16.00 mm (0.63 in)
Caliper cylinder inside diameter	24.05 mm × 3 (0.95 in × 3)
Recommended fluid	DOT 4

Rear brake

Type	Single disc brake
Operation	Right foot operation
Brake pedal position	21.0 mm (0.83 in)
Rear disc brake	
Disc outside diameter × thickness	298.0 × 6.0 mm (11.73 × 0.24 in)
Brake disc thickness limit	5.5 mm (0.22 in)
Brake disc deflection limit	0.15 mm (0.0059 in)
Brake pad lining thickness (inner)	5.4 mm (0.21 in)
Limit	0.8 mm (0.03 in)
Brake pad lining thickness (outer)	5.4 mm (0.21 in)
Limit	0.8 mm (0.03 in)
Master cylinder inside diameter	14.0 mm (0.55 in)
Caliper cylinder inside diameter	41.30 mm (1.63 in)
Recommended fluid	DOT 4

Clutch

Recommended fluid	DOT 4
Release cylinder inside diameter	33.6 mm (1.32 in)
Master cylinder inside diameter	14.0 mm (0.55 in)

Steering

Steering bearing type	Taper roller bearing
Center to lock angle (left)	35.0°
Center to lock angle (right)	35.0°

Front suspension

Type	Telescopic fork
Spring/shock absorber type	Coil spring/oil damper
Front fork travel	120.0 mm (4.72 in)
Fork spring free length	255.0 mm (10.04 in)
Limit	251.0 mm (9.88 in)
Collar length	222.6 mm (8.76 in)
Spring rate K1	8.30 N/mm (0.85 kgf/mm, 47.39 lb/in)
Spring stroke K1	0.0–120.0 mm (0.00–4.72 in)
Inner tube outer diameter	52.0 mm (2.05 in)
Inner tube bending limit	0.2 mm (0.01 in)
Optional spring available	No
Recommended oil	Suspension oil M1
Quantity	915.0 cm ³ (30.94 US oz, 32.27 Imp.oz)
Level	104.0 mm (4.09 in)
Spring preload adjusting positions	
Minimum	5

CHASSIS SPECIFICATIONS

Standard	4
Maximum	1
Rebound damping adjusting positions	
Minimum	17 click(s) out*
Standard	12 click(s) out*
Maximum	1 click(s) out*
Compression damping adjusting positions	
Minimum	20 click(s) out*
Standard	12 click(s) out*
Maximum	1 click(s) out*

Rear suspension

Type	Swingarm (link suspension)
Spring/shock absorber type	Coil spring/gas-oil damper
Rear shock absorber assembly travel	50.0 mm (1.97 in)
Spring free length	166.0 mm (6.54 in)
Limit	162.0 mm (6.38 in)
Installed length	159.5 mm (6.28 in)
Spring rate K1	186.40 N/mm (19.01 kgf/mm, 1064.34 lb/in)
Spring stroke K1	0.0–50.0 mm (0.00–1.97 in)
Optional spring available	No
Spring preload adjusting positions	
Minimum	11
Standard	6
Maximum	1
Rebound damping adjusting positions	
Minimum	20 click(s) out*
Standard	12 click(s) out*
Maximum	3 click(s) out*
Compression damping adjusting positions	
Minimum	12 click(s) out*
Standard	10 click(s) out*
Maximum	1 click(s) out*

Swingarm

Swingarm end free play limit (radial)	0.0 mm (0.0 in)
Swingarm end free play limit (axial)	0.0 mm (0.00 in)

ELECTRICAL SPECIFICATIONS

EAS20310

ELECTRICAL SPECIFICATIONS

Voltage

System voltage 12 V

Ignition system

Ignition system TCI (digital)
Advancer type Throttle position sensor and electrical
Ignition timing (B.T.D.C.) 3.0°/900 r/min

Engine control unit

Model/manufacture TBDF56/DENSO

Ignition coil

Minimum ignition spark gap 6.0 mm (0.24 in)
Primary coil resistance 1.19–1.61 Ω
Secondary coil resistance 8.50–11.50 kΩ

AC magneto

Standard output 14.0 V, 30.0 A at 5000 r/min
Stator coil resistance 0.184–0.276 Ω at 20 °C (68 °F)

Voltage regulator

Rectifier/regulator
Regulator type Semi conductor-short circuit
No load regulated voltage 14.2–14.8 V
Rectifier capacity 50.0 A

Battery

Model YTZ14S
Voltage, capacity 12 V, 11.2 Ah
Specific gravity 1.31
Ten hour rate amperage 1.12 A

Headlight

Bulb type Halogen bulb

Bulb voltage, wattage × quantity

Headlight 12 V, 60 W/55.0 W × 1
Auxiliary light 12 V, 5.0 W × 1
Tail/brake light LED
Front turn signal/position light 12 V, 21 W/5.0 W × 2
Rear turn signal light 12 V, 21.0 W × 2
Meter lighting LED

Indicator light

Neutral indicator light LED
Turn signal indicator light LED × 2
Oil level warning light LED
High beam indicator light LED
Fuel level warning light LED
Coolant temperature warning light LED

ELECTRICAL SPECIFICATIONS

Engine trouble warning light	LED
ABS warning light	LED

Electric starting system	
System type	Constant mesh

Starter motor	
Power output	0.90 kW
Armature coil resistance	0.0081–0.0099 Ω
Brush overall length	11.3 mm (0.44 in)
Limit	7.60 mm (0.30 in)
Brush spring force	7.36–11.04 N (750–1126 gf, 26.49–39.74 oz)
Commutator diameter	28.0 mm (1.10 in)
Limit	27.0 mm (1.06 in)
Mica undercut (depth)	1.00 mm (0.04 in)

Starter relay	
Coil resistance	4.18–4.62 Ω

Horn	
Horn type	Plane
Quantity	1 pc
Maximum amperage	3.0 A

Turn signal/hazard relay	
Relay type	Full transistor
Built-in, self-canceling device	No
Turn signal blinking frequency	75–95 cycles/min

Fuel sender unit	
Sender unit resistance (full)	19.0–21.0 Ω
Sender unit resistance (empty)	139.0–141.0 Ω

Starting circuit cut-off relay	
Coil resistance	162.0–198.0 Ω

Headlight relay	
Coil resistance	86.40–105.60 Ω

Fuel pump relay	
Coil resistance	162–198 Ω

Fuses	
Main fuse	50.0 A
Headlight fuse	15.0 A
Signaling system fuse	15.0 A
Ignition fuse	20.0 A
Radiator fan fuse	20.0 A
Sub radiator fan fuse	7.5 A
Fuel injection system fuse	15.0 A
ABS motor fuse	30.0 A
ABS ECU fuse	7.5 A
ABS solenoid fuse	15.0 A

ELECTRICAL SPECIFICATIONS

Backup fuse	7.5 A
Electronic throttle valve fuse	7.5 A
Spare fuse	20.0 A
Spare fuse	15.0 A × 2
Spare fuse	7.5 A
Spare fuse	30.0 A

EAS20320

TIGHTENING TORQUES

EAS20330

GENERAL TIGHTENING TORQUE SPECIFICATIONS

This chart specifies tightening torques for standard fasteners with a standard ISO thread pitch. Tightening torque specifications for special components or assemblies are provided for each chapter of this manual. To avoid warpage, tighten multi-fastener assemblies in a crisscross pattern and progressive stages until the specified tightening torque is reached. Unless otherwise specified, tightening torque specifications require clean, dry threads. Components should be at room temperature.

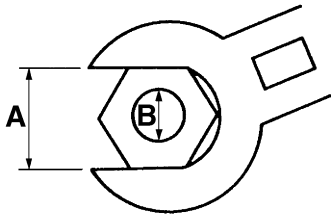



















- A. Distance between flats
- B. Outside thread diameter

A (nut)	B (bolt)	General tightening torques		
		Nm	m·kgf	ft·lbf
10 mm	6 mm	6	0.6	4.3
12 mm	8 mm	15	1.5	11
14 mm	10 mm	30	3.0	22
17 mm	12 mm	55	5.5	40
19 mm	14 mm	85	8.5	61
22 mm	16 mm	130	13.0	94











TIGHTENING TORQUES

EAS20340







ENGINE TIGHTENING TORQUES

Item	Thread size	Q'ty	Tightening torque	Remarks
Throttle body joint bolt	M6	8	10 Nm (1.0 m·kgf, 7.2 ft·lbf)	
Spark plug	M10	4	13 Nm (1.3 m·kgf, 9.4 ft·lbf)	
Cylinder head bolt	M10	16	See TIP.	
Camshaft cap bolt	M6	32	10 Nm (1.0 m·kgf, 7.2 ft·lbf)	
Cylinder head cover bolt	M6	8	12 Nm (1.2 m·kgf, 8.7 ft·lbf)	
Cylinder head stud bolt	M12	2	25 Nm (2.5 m·kgf, 18 ft·lbf)	
Cylinder head stud bolt (exhaust pipe)	M8	8	15 Nm (1.5 m·kgf, 11 ft·lbf)	
Engine oil check bolt	M10	5	20 Nm (2.0 m·kgf, 14 ft·lbf)	
Reed valve cover bolt	M6	6	10 Nm (1.0 m·kgf, 7.2 ft·lbf)	
Cylinder head side cover plate bolt	M5	8	5 Nm (0.5 m·kgf, 3.6 ft·lbf)	
Cylinder head side cover and cylinder head side cover plate bolt	M5	8	5 Nm (0.5 m·kgf, 3.6 ft·lbf)	
Cylinder head side cover bolt	M5	8	5 Nm (0.5 m·kgf, 3.6 ft·lbf)	
Cylinder head breather pipe bolt (upper side)	M6	1	10 Nm (1.0 m·kgf, 7.2 ft·lbf)	
Cylinder head breather pipe bolt (lower side)	M6	1	10 Nm (1.0 m·kgf, 7.2 ft·lbf)	
Crankcase breather pipe bolt	M6	1	10 Nm (1.0 m·kgf, 7.2 ft·lbf)	
Air cut-off valve bracket bolt	M6	2	10 Nm (1.0 m·kgf, 7.2 ft·lbf)	
Connecting rod bolt	M8	8	See TIP.	
Generator rotor bolt	M12	1	80 Nm (8.0 m·kgf, 58 ft·lbf)	
Balancer drive gear bolt	M10	1	40 Nm (4.0 m·kgf, 29 ft·lbf)	
Camshaft sprocket bolt	M7	4	24 Nm (2.4 m·kgf, 17 ft·lbf)	
Camshaft gear bolt	M6	4	24 Nm (2.4 m·kgf, 17 ft·lbf)	
Timing chain tensioner bolt	M6	4	10 Nm (1.0 m·kgf, 7.2 ft·lbf)	
Timing chain guide stopper bolt	M6	2	10 Nm (1.0 m·kgf, 7.2 ft·lbf)	
Timing chain guide assembly bracket bolt	M6	4	10 Nm (1.0 m·kgf, 7.2 ft·lbf)	
Timing chain guide assembly bolt	M6	2	10 Nm (1.0 m·kgf, 7.2 ft·lbf)	
Water pump cover bolt	M6	6	10 Nm (1.0 m·kgf, 7.2 ft·lbf)	
Water pump inlet pipe bolt	M6	1	10 Nm (1.0 m·kgf, 7.2 ft·lbf)	
Water pump outlet pipe bolt	M6	1	10 Nm (1.0 m·kgf, 7.2 ft·lbf)	
Thermostat inlet pipe bolt	M6	4	10 Nm (1.0 m·kgf, 7.2 ft·lbf)	
Thermostat assembly nut	M6	2	10 Nm (1.0 m·kgf, 7.2 ft·lbf)	
Thermostat bracket and thermostat bolt	M6	1	7 Nm (0.7 m·kgf, 5.1 ft·lbf)	



















TIGHTENING TORQUES

Item	Thread size	Q'ty	Tightening torque	Remarks
Thermostat bracket bolt	M6	2	10 Nm (1.0 m·kgf, 7.2 ft·lbf)	
Oil cooler union bolt	M20	1	63 Nm (6.3 m·kgf, 45 ft·lbf)	
Engine oil drain bolt	M14	1	43 Nm (4.3 m·kgf, 31 ft·lbf)	
Oil strainer bolt	M6	1	10 Nm (1.0 m·kgf, 7.2 ft·lbf)	
Oil pipe 2 and oil strainer bolt	M6	1	10 Nm (1.0 m·kgf, 7.2 ft·lbf)	
Oil pump bolt	M6	3	10 Nm (1.0 m·kgf, 7.2 ft·lbf)	
Oil pan bolt	M6	3	10 Nm (1.0 m·kgf, 7.2 ft·lbf)	
Oil pan bolt	M6	10	10 Nm (1.0 m·kgf, 7.2 ft·lbf)	
Oil level switch lead holder and oil pan bolt	M6	1	10 Nm (1.0 m·kgf, 7.2 ft·lbf)	
Oil pipe 1 bolt (lower side)	M6	1	10 Nm (1.0 m·kgf, 7.2 ft·lbf)	
Oil filter cartridge	M20	1	17 Nm (1.7 m·kgf, 12 ft·lbf)	
Oil cooler adapter bolt	M6	4	12 Nm (1.2 m·kgf, 8.7 ft·lbf)	l=40 mm (1.57 in) 
Oil cooler adapter bolt	M6	2	12 Nm (1.2 m·kgf, 8.7 ft·lbf)	l=30 mm (1.18 in)
Oil pipe 3 bolt	M6	1	10 Nm (1.0 m·kgf, 7.2 ft·lbf)	
Oil pipe 1 bolt (upper side)	M10	2	18 Nm (1.8 m·kgf, 13 ft·lbf)	
Oil nozzle bolt	M6	4	10 Nm (1.0 m·kgf, 7.2 ft·lbf)	
Throttle body joint clamp screw	M4	4	3 Nm (0.3 m·kgf, 2.2 ft·lbf)	
Throttle cable locknut	M6	2	5 Nm (0.5 m·kgf, 3.6 ft·lbf)	
Fixed intake funnel bolt	M6	8	6 Nm (0.6 m·kgf, 4.3 ft·lbf)	
Air filter case screw	M5	11	2.5 Nm (0.25 m·kgf, 1.8 ft·lbf)	
Air filter case cover screw	M5	8	2.5 Nm (0.25 m·kgf, 1.8 ft·lbf)	
Variable intake funnel holder shaft	M6	1	4.5 Nm (0.45 m·kgf, 3.3 ft·lbf)	
Intake funnel servo motor bolt	M5	3	3.5 Nm (0.35 m·kgf, 2.5 ft·lbf)	
Throttle servo motor coupler bracket bolt	M6	1	7 Nm (0.7 m·kgf, 5.1 ft·lbf)	
Throttle position sensor screw	M5	2	3.5 Nm (0.35 m·kgf, 2.5 ft·lbf)	
Accelerator position sensor screw	M5	2	3.5 Nm (0.35 m·kgf, 2.5 ft·lbf)	
Intake air temperature sensor screw	M5	1	3.5 Nm (0.35 m·kgf, 2.5 ft·lbf)	
Injector joint screw	M5	4	3.5 Nm (0.35 m·kgf, 2.5 ft·lbf)	
Exhaust pipe nut	M8	8	20 Nm (2.0 m·kgf, 14 ft·lbf)	
Left front exhaust pipe and right front exhaust pipe bolt	M8	1	10 Nm (1.0 m·kgf, 7.2 ft·lbf)	
Rear exhaust pipe and exhaust chamber bolt	M6	2	10 Nm (1.0 m·kgf, 7.2 ft·lbf)	



TIGHTENING TORQUES

Item	Thread size	Q'ty	Tightening torque	Remarks
Front exhaust pipe and exhaust chamber bolt	M8	2	20 Nm (2.0 m·kgf, 14 ft·lbf)	
Rear exhaust pipe protector bolt	M6	4	8 Nm (0.8 m·kgf, 5.8 ft·lbf)	
Exhaust chamber bracket bolt (front side)	M8	1	20 Nm (2.0 m·kgf, 14 ft·lbf)	
Exhaust chamber bracket bolt (left and right sides)	M6	4	7 Nm (0.7 m·kgf, 5.1 ft·lbf)	
Exhaust chamber bolt	M8	3	20 Nm (2.0 m·kgf, 14 ft·lbf)	
Exhaust chamber and muffler bolt	M8	2	20 Nm (2.0 m·kgf, 14 ft·lbf)	
Muffler bolt	M8	2	20 Nm (2.0 m·kgf, 14 ft·lbf)	
Muffler protector bolt	M6	4	10 Nm (1.0 m·kgf, 7.2 ft·lbf)	
O ₂ sensor	M18	1	45 Nm (4.5 m·kgf, 32 ft·lbf)	
EXUP cable locknut	M6	2	6 Nm (0.6 m·kgf, 4.3 ft·lbf)	
EXUP servo motor bolt	M6	2	7 Nm (0.7 m·kgf, 5.1 ft·lbf)	
EXUP valve pulley cover bolt	M6	3	8 Nm (0.8 m·kgf, 5.8 ft·lbf)	
Crankcase bolt	M10	8	See TIP.	l=150 mm (5.91 in) 
Crankcase bolt	M8	3	24 Nm (2.4 m·kgf, 17 ft·lbf)	l=110 mm (4.33 in) 
Crankcase bolt	M8	13	24 Nm (2.4 m·kgf, 17 ft·lbf)	l=90 mm (3.54 in) 
Crankcase bolt	M8	12	24 Nm (2.4 m·kgf, 17 ft·lbf)	l=65 mm (2.56 in) 
Crankcase bolt	M6	6	10 Nm (1.0 m·kgf, 7.2 ft·lbf)	l=65 mm (2.56 in) 
Main gallery bolt	M20	2	8 Nm (0.8 m·kgf, 5.8 ft·lbf)	
Crankshaft end accessing screw	M32	1	2 Nm (0.2 m·kgf, 1.4 ft·lbf)	
Timing mark accessing screw	M14	1	2 Nm (0.2 m·kgf, 1.4 ft·lbf)	
Engine oil filler cap	M27	1	2 Nm (0.2 m·kgf, 1.4 ft·lbf)	
Upper crankcase plug (upper side)	M36	1	8 Nm (0.8 m·kgf, 5.8 ft·lbf)	
Upper crankcase plug (right side)	M14	1	6 Nm (0.6 m·kgf, 4.3 ft·lbf)	
Generator cover bolt	M6	12	10 Nm (1.0 m·kgf, 7.2 ft·lbf)	
Generator cover plate bolt	M6	6	12 Nm (1.2 m·kgf, 8.7 ft·lbf)	
Crankshaft position sensor/stator assembly lead holder 1 bolt	M6	2	10 Nm (1.0 m·kgf, 7.2 ft·lbf)	
Middle gear side cover bolt	M6	6	12 Nm (1.2 m·kgf, 8.7 ft·lbf)	

TIGHTENING TORQUES

Item	Thread size	Q'ty	Tightening torque	Remarks
Crankcase cover bolt	M6	15	10 Nm (1.0 m·kgf, 7.2 ft·lbf)	
Clutch cover bolt	M6	5	12 Nm (1.2 m·kgf, 8.7 ft·lbf)	l=70 mm (2.76 in)
Clutch cover bolt	M6	3	12 Nm (1.2 m·kgf, 8.7 ft·lbf)	l=25 mm (0.98 in)
Plate bolt	M8	1	20 Nm (2.0 m·kgf, 14 ft·lbf)	
Plate bolt	M6	1	10 Nm (1.0 m·kgf, 7.2 ft·lbf)	
Clutch release cylinder cover bolt	M6	4	10 Nm (1.0 m·kgf, 7.2 ft·lbf)	
Clutch release cylinder bolt	M6	2	10 Nm (1.0 m·kgf, 7.2 ft·lbf)	
Clutch hose union bolt (release cylinder side)	M10	1	30 Nm (3.0 m·kgf, 22 ft·lbf)	
Clutch release cylinder bleed screw	M8	1	5 Nm (0.5 m·kgf, 3.6 ft·lbf)	
Gear position switch lead holder bolt	M6	1	10 Nm (1.0 m·kgf, 7.2 ft·lbf)	
Crankshaft position sensor/stator assembly lead holder 2 bolt	M6	1	10 Nm (1.0 m·kgf, 7.2 ft·lbf)	
Clutch cover damper plate bolt	M6	5	10 Nm (1.0 m·kgf, 7.2 ft·lbf)	
Ventilation chamber cover bolt	M6	8	10 Nm (1.0 m·kgf, 7.2 ft·lbf)	
Starter clutch bolt	M8	6	32 Nm (3.2 m·kgf, 23 ft·lbf)	
Clutch boss nut	M20	1	95 Nm (9.5 m·kgf, 68 ft·lbf)	Stake. 
Clutch spring plate retainer bolt	M6	6	8 Nm (0.8 m·kgf, 5.8 ft·lbf)	
Clutch boss plate stud bolt	M8	6	25 Nm (2.5 m·kgf, 18 ft·lbf)	
Main axle bearing retainer bolt	M6	3	12 Nm (1.2 m·kgf, 8.7 ft·lbf)	
Middle drive pinion gear nut	M44	1	110 Nm (11.0 m·kgf, 80 ft·lbf)	Stake.
Middle drive pinion gear bearing retainer bolt	M8	4	24 Nm (2.4 m·kgf, 17 ft·lbf)	
Middle driven pinion gear bearing housing bolt	M8	4	30 Nm (3.0 m·kgf, 22 ft·lbf)	
Stopper lever bolt	M6	1	10 Nm (1.0 m·kgf, 7.2 ft·lbf)	
Shift drum retainer bolt	M6	2	10 Nm (1.0 m·kgf, 7.2 ft·lbf)	
Shift shaft spring stopper bolt	M8	1	22 Nm (2.2 m·kgf, 16 ft·lbf)	
Crankshaft position sensor bolt	M5	2	7 Nm (0.7 m·kgf, 5.1 ft·lbf)	
Stator coil bolt	M6	3	10 Nm (1.0 m·kgf, 7.2 ft·lbf)	
Starter motor assembly bolt	M8	2	20 Nm (2.0 m·kgf, 14 ft·lbf)	
Starter motor terminal nut	M6	1	7 Nm (0.7 m·kgf, 5.1 ft·lbf)	
Oil level switch bolt	M6	2	10 Nm (1.0 m·kgf, 7.2 ft·lbf)	
Gear position switch bolt	M5	2	5 Nm (0.5 m·kgf, 3.6 ft·lbf)	
Coolant temperature sensor	M12	1	18 Nm (1.8 m·kgf, 13 ft·lbf)	

TIGHTENING TORQUES

Item	Thread size	Q'ty	Tightening torque	Remarks
Cylinder identification sensor bolt	M6	1	8 Nm (0.8 m·kgf, 5.8 ft·lbf)	
Upper radiator bracket bolt	M6	2	10 Nm (1.0 m·kgf, 7.2 ft·lbf)	
Lower radiator bracket bolt	M6	6	7 Nm (0.7 m·kgf, 5.1 ft·lbf)	
Upper/lower radiator bracket bolt	M6	2	7 Nm (0.7 m·kgf, 5.1 ft·lbf)	
Coolant reservoir and right lower radiator bracket bolt	M6	1	7 Nm (0.7 m·kgf, 5.1 ft·lbf)	
Upper radiator bolt	M6	1	10 Nm (1.0 m·kgf, 7.2 ft·lbf)	
Coolant reservoir cap guide	M6	1	8 Nm (0.8 m·kgf, 5.8 ft·lbf)	
Radiator cover bolt	M6	4	7 Nm (0.7 m·kgf, 5.1 ft·lbf)	
Radiator side panel bolt	M6	7	8 Nm (0.8 m·kgf, 5.8 ft·lbf)	
Radiator fan motor bolt	M6	5	8 Nm (0.8 m·kgf, 5.8 ft·lbf)	

TIP

Cylinder head bolt

Tighten the cylinder head bolts to 30 Nm (3.0 m·kgf, 22 ft·lbf), and then tighten them further to reach the specified angle 85–95°.

TIP

Crankcase bolt

Tighten the crankcase bolts (M10) to 30 Nm (3.0 m·kgf, 22 ft·lbf) in the proper tightening sequence. Then, retighten the bolts one at a time as follows:

- Loosen the crankcase bolt.
- Tighten the crankcase bolt to 25 Nm (2.5 m·kgf, 11 ft·lbf).
- Tighten the crankcase bolt further to reach the specified angle 80°.

TIP

Connecting rod bolt

Tighten the connecting rod bolts to 20 Nm (2.0 m·kgf, 14 ft·lbf), and then tighten them further to reach the specified angle 130–140°.

Cylinder head tightening sequence

A

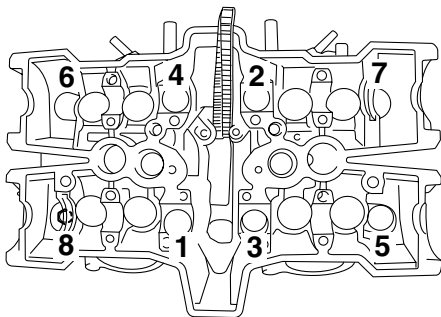

B

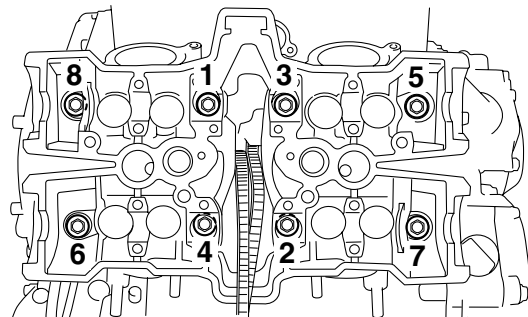

- A. Front cylinder head
B. Rear cylinder head

Crankcase tightening sequence

A

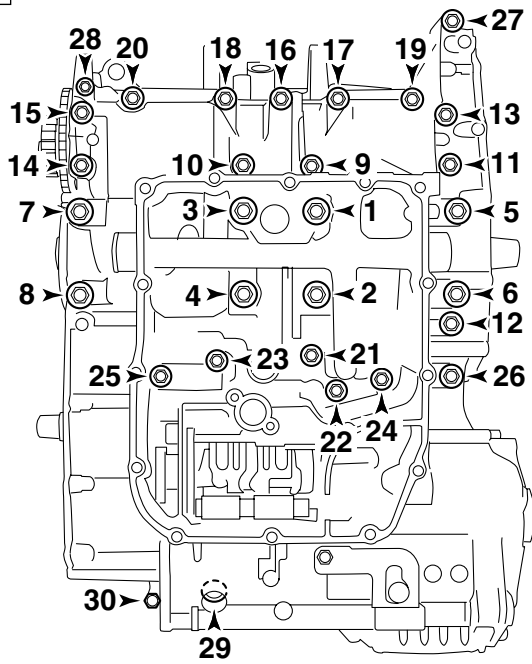

B

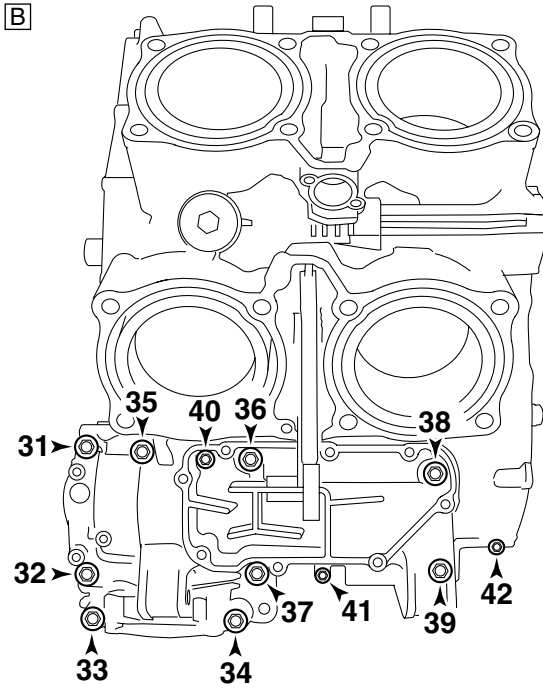







- A. Lower crankcase
- B. Upper crankcase







TIGHTENING TORQUES

EAS20350







CHASSIS TIGHTENING TORQUES

Item	Thread size	Q'ty	Tightening torque	Remarks
Engine bracket bolt (front side)	M12	3	60 Nm (6.0 m·kgf, 43 ft·lbf)	
Engine mounting bolt (front side)	M12	1	60 Nm (6.0 m·kgf, 43 ft·lbf)	
Engine mounting nut (front side)	M12	2	60 Nm (6.0 m·kgf, 43 ft·lbf)	
Engine bracket bolt (left and right sides)	M10	4	60 Nm (6.0 m·kgf, 43 ft·lbf)	
Engine mounting bolt (left and right sides)	M10	4	60 Nm (6.0 m·kgf, 43 ft·lbf)	
Engine mounting bolt (rear upper side)	M12	2	60 Nm (6.0 m·kgf, 43 ft·lbf)	
Engine mounting nut (rear lower side)	M12	1	60 Nm (6.0 m·kgf, 43 ft·lbf)	
Relay arm bracket bolt	M10	3	48 Nm (4.8 m·kgf, 35 ft·lbf)	
Battery box bracket bolt	M8	4	26 Nm (2.6 m·kgf, 19 ft·lbf)	
Rear frame bolt	M10	4	41 Nm (4.1 m·kgf, 30 ft·lbf)	
Rider seat bracket bolt	M6	4	7 Nm (0.7 m·kgf, 5.1 ft·lbf)	
Rider seat bolt	M6	2	7 Nm (0.7 m·kgf, 5.1 ft·lbf)	
Passenger seat bracket bolt	M6	2	7 Nm (0.7 m·kgf, 5.1 ft·lbf)	
Passenger seat bolt	M6	2	10 Nm (1.0 m·kgf, 7.2 ft·lbf)	
Brake fluid reservoir bolt	M6	1	7 Nm (0.7 m·kgf, 5.1 ft·lbf)	
Brake hose joint holder bolt	M6	1	7 Nm (0.7 m·kgf, 5.1 ft·lbf)	
Left pivot bolt	M28	1	100 Nm (10.0 m·kgf, 72 ft·lbf)	
Right pivot bolt	M28	1	7 Nm (0.7 m·kgf, 5.1 ft·lbf)	
Pivot bolt locknut	M28	1	100 Nm (10.0 m·kgf, 72 ft·lbf)	
Connecting arm and swingarm locknut	M10	1	48 Nm (4.8 m·kgf, 35 ft·lbf)	
Connecting arm and swingarm nut	M16	1	48 Nm (4.8 m·kgf, 35 ft·lbf)	
Connecting arm and swingarm bolt	M10	1	8 Nm (0.8 m·kgf, 5.8 ft·lbf)	
Connecting arm and relay arm locknut	M18	1	56 Nm (5.6 m·kgf, 40 ft·lbf)	
Connecting arm and relay arm nut	M12	1	70 Nm (7.0 m·kgf, 50 ft·lbf)	
Connecting arm and relay arm bolt	M12	1	8 Nm (0.8 m·kgf, 5.8 ft·lbf)	
Relay arm and relay arm bracket nut	M12	1	70 Nm (7.0 m·kgf, 50 ft·lbf)	
Relay arm and relay arm bracket locknut	M18	1	56 Nm (5.6 m·kgf, 40 ft·lbf)	
Relay arm and relay arm bracket bolt	M12	1	8 Nm (0.8 m·kgf, 5.8 ft·lbf)	











TIGHTENING TORQUES

Item	Thread size	Q'ty	Tightening torque	Remarks
Rear shock absorber assembly lower bolt	M14	1	45 Nm (4.5 m·kgf, 32 ft·lbf)	
Swingarm damper bolt	M8	1	16 Nm (1.6 m·kgf, 11 ft·lbf)	
Torque stop pin	M22	1	115 Nm (11.5 m·kgf, 85 ft·lbf)	
Rebound damping adjusting hose guide bolt	M6	1	7 Nm (0.7 m·kgf, 5.1 ft·lbf)	
Rebound damping adjusting knob bolt	M6	1	7 Nm (0.7 m·kgf, 5.1 ft·lbf)	
Brake hose guide bolt	M6	2	7 Nm (0.7 m·kgf, 5.1 ft·lbf)	
Rear shock absorber assembly upper nut	M10	1	45 Nm (4.5 m·kgf, 32 ft·lbf)	
Brake hose holder bolt	M6	2	7 Nm (0.7 m·kgf, 5.1 ft·lbf)	
Right rider footrest bolt	M8	2	28 Nm (2.8 m·kgf, 20 ft·lbf)	
Brake hose cover bolt	M6	2	7 Nm (0.7 m·kgf, 5.1 ft·lbf)	
Upper bracket pinch bolt	M8	2	26 Nm (2.6 m·kgf, 19 ft·lbf)	
Grip end bolt	M6	2	7 Nm (0.7 m·kgf, 5.1 ft·lbf)	
Clutch master cylinder holder bolt	M6	2	14 Nm (1.4 m·kgf, 10 ft·lbf)	
Clutch hose union bolt (master cylinder side)	M10	1	30 Nm (3.0 m·kgf, 22 ft·lbf)	
SELECT/RESET button unit bolt	M6	2	7 Nm (0.7 m·kgf, 5.1 ft·lbf)	
Steering stem nut	M22	1	115 Nm (11.5 m·kgf, 85 ft·lbf)	
Handlebar holder bolt	M8	4	28 Nm (2.8 m·kgf, 20 ft·lbf)	
Lower ring nut (initial tightening torque)	M28	1	52 Nm (5.2 m·kgf, 37 ft·lbf)	See TIP.
Lower ring nut (final tightening torque)	M28	1	18 Nm (1.8 m·kgf, 13 ft·lbf)	See TIP.
Lower handlebar holder nut	M10	2	32 Nm (3.2 m·kgf, 23 ft·lbf)	
Brake master cylinder holder bolt	M6	2	14 Nm (1.4 m·kgf, 10 ft·lbf)	
Lower bracket pinch bolt	M8	4	23 Nm (2.3 m·kgf, 17 ft·lbf)	
Front fork cap bolt	M50	2	25 Nm (2.5 m·kgf, 18 ft·lbf)	
Damper assembly locknut	M10	2	22 Nm (2.2 m·kgf, 16 ft·lbf)	
Damper rod bolt	M10	2	35 Nm (3.5 m·kgf, 25 ft·lbf)	
Brake hose union bolt (front brake master cylinder side)	M10	1	30 Nm (3.0 m·kgf, 22 ft·lbf)	
Brake hose holder bolt	M6	3	10 Nm (1.0 m·kgf, 7.2 ft·lbf)	
Front fender holder and front fender bolt	M6	1	10 Nm (1.0 m·kgf, 7.2 ft·lbf)	
Front fender outer bracket bolt	M6	6	10 Nm (1.0 m·kgf, 7.2 ft·lbf)	
Front fender holder and left front fender inner bracket bolt	M6	1	10 Nm (1.0 m·kgf, 7.2 ft·lbf)	
Front fork leg protector bolt	M6	4	10 Nm (1.0 m·kgf, 7.2 ft·lbf)	









TIGHTENING TORQUES

Item	Thread size	Q'ty	Tightening torque	Remarks
Battery box bolt	M6	3	10 Nm (1.0 m·kgf, 7.2 ft·lbf)	
Brake hose holder and bracket of the upper radiator bolt	M6	1	7 Nm (0.7 m·kgf, 5.1 ft·lbf)	
Brake hose flare nut	M10	2	21 Nm (2.1 m·kgf, 15 ft·lbf)	
Brake hose flare nut (hydraulic unit assembly)	M10	4	16 Nm (1.6 m·kgf, 11 ft·lbf)	
Hydraulic unit assembly box bolt	M6	3	7 Nm (0.7 m·kgf, 5.1 ft·lbf)	
Hydraulic unit assembly box bolt	M8	2	16 Nm (1.6 m·kgf, 11 ft·lbf)	
Brake hose holder and battery box bracket bolt	M6	1	7 Nm (0.7 m·kgf, 5.1 ft·lbf)	
Fuel pump nut	M6	6	10 Nm (1.0 m·kgf, 7.2 ft·lbf)	
Filler neck nut	M6	6	10 Nm (1.0 m·kgf, 7.2 ft·lbf)	
Fuel tank protector and brake hose holder bolt	M6	1	7 Nm (0.7 m·kgf, 5.1 ft·lbf)	
Front wheel axle bolt	M14	1	81 Nm (8.1 m·kgf, 59 ft·lbf)	See TIP.
Front wheel axle pinch bolt	M8	4	21 Nm (2.1 m·kgf, 15 ft·lbf)	
Front brake caliper bolt	M10	4	35 Nm (3.5 m·kgf, 25 ft·lbf)	
Front brake caliper bleed screw	M8	2	5 Nm (0.5 m·kgf, 3.6 ft·lbf)	
Front wheel sensor lead holder bolt	M6	1	7 Nm (0.7 m·kgf, 5.1 ft·lbf)	
Brake hose union bolt (front brake caliper side)	M10	1	30 Nm (3.0 m·kgf, 22 ft·lbf)	
Front wheel sensor bolt	M6	1	7 Nm (0.7 m·kgf, 5.1 ft·lbf)	
Rear wheel sensor bolt	M6	1	7 Nm (0.7 m·kgf, 5.1 ft·lbf)	
Rear wheel axle	M24	1	98 Nm (9.8 m·kgf, 71 ft·lbf)	
Rear wheel axle pinch bolt	M8	2	16 Nm (1.6 m·kgf, 11 ft·lbf)	
Rear wheel sensor holder bolt	M6	1	7 Nm (0.7 m·kgf, 5.1 ft·lbf)	
Front brake disc bolt	M6	10	18 Nm (1.8 m·kgf, 13 ft·lbf)	
Rear brake disc bolt	M8	5	23 Nm (2.3 m·kgf, 17 ft·lbf)	
Front wheel sensor rotor bolt	M5	5	8 Nm (0.8 m·kgf, 5.8 ft·lbf)	
Rear wheel sensor rotor bolt	M5	5	8 Nm (0.8 m·kgf, 5.8 ft·lbf)	
Rear wheel ring bolt	M6	5	10 Nm (1.0 m·kgf, 7.2 ft·lbf)	
Rear wheel bearing retainer	M53	1	80 Nm (8.0 m·kgf, 58 ft·lbf)	
Brake hose union bolt (rear brake master cylinder side)	M10	1	30 Nm (3.0 m·kgf, 22 ft·lbf)	
Brake hose union bolt (rear brake caliper cylinder side)	M10	1	30 Nm (3.0 m·kgf, 22 ft·lbf)	
Rear brake master cylinder bolt	M8	2	28 Nm (2.8 m·kgf, 20 ft·lbf)	
Rear brake master cylinder lock-nut	M8	1	16 Nm (1.6 m·kgf, 11 ft·lbf)	

TIGHTENING TORQUES

Item	Thread size	Q'ty	Tightening torque	Remarks
Rear brake caliper retaining bolt	M10	2	27 Nm (2.7 m·kgf, 19 ft·lbf)	
Rear brake caliper bleed screw	M7	1	6 Nm (0.6 m·kgf, 4.3 ft·lbf)	
Brake pedal pinch bolt	M6	1	8 Nm (0.8 m·kgf, 5.8 ft·lbf)	
Brake pedal bolt	M6	1	8 Nm (0.8 m·kgf, 5.8 ft·lbf)	
Rear brake light switch bracket	M5	2	4 Nm (0.4 m·kgf, 2.9 ft·lbf)	
Passenger footrest bolt	M8	4	26 Nm (2.6 m·kgf, 19 ft·lbf)	
Gas tank (rear shock absorber assembly) bolt	M6	2	10 Nm (1.0 m·kgf, 7.2 ft·lbf)	
Spring preload adjusting knob bracket bolt	M6	2	10 Nm (1.0 m·kgf, 7.2 ft·lbf)	
Side cover inner panel bolt (lower and rear side)	M6	4	10 Nm (1.0 m·kgf, 7.2 ft·lbf)	
Side cover inner panel bolt (upper side)	M6	2	10 Nm (1.0 m·kgf, 7.2 ft·lbf)	
Rollover valve bolt	M6	1	2 Nm (0.2 m·kgf, 1.4 ft·lbf)	
EXUP servo motor bracket bolt	M6	2	7 Nm (0.7 m·kgf, 5.1 ft·lbf)	
Wire harness mounting panel bracket bolt	M6	2	7 Nm (0.7 m·kgf, 5.1 ft·lbf)	
Throttle servo motor coupler bracket bolt	M6	1	7 Nm (0.7 m·kgf, 5.1 ft·lbf)	
Pivot bolt cover plate bolt	M6	10	7 Nm (0.7 m·kgf, 5.1 ft·lbf)	
Side panel bolt	M6	4	10 Nm (1.0 m·kgf, 7.2 ft·lbf)	
Side panel and passenger footrest bolt	M6	2	10 Nm (1.0 m·kgf, 7.2 ft·lbf)	
Horn bolt	M8	1	16 Nm (1.6 m·kgf, 11 ft·lbf)	
Horn bracket bolt	M6	2	10 Nm (1.0 m·kgf, 7.2 ft·lbf)	
Horn cover bolt	M5	1	4 Nm (0.4 m·kgf, 2.9 ft·lbf)	
Rectifier/regulator bolt	M6	2	7 Nm (0.7 m·kgf, 5.1 ft·lbf)	
Rear turn signal light assembly bolt	M6	4	10 Nm (1.0 m·kgf, 7.2 ft·lbf)	
License plate light assembly bolt	M6	4	10 Nm (1.0 m·kgf, 7.2 ft·lbf)	
Mudguard 1 bolt	M6	2	7 Nm (0.7 m·kgf, 5.1 ft·lbf)	
License plate bracket nut	M6	2	7 Nm (0.7 m·kgf, 5.1 ft·lbf)	
Coupler holder bolt	M6	2	7 Nm (0.7 m·kgf, 5.1 ft·lbf)	
Front turn signal/position light bolt	M6	2	7 Nm (0.7 m·kgf, 5.1 ft·lbf)	
Turn signal/position light pinch bolt	M6	2	7 Nm (0.7 m·kgf, 5.1 ft·lbf)	
Headlight top cover and meter assembly 1 bracket bolt	M6	2	7 Nm (0.7 m·kgf, 5.1 ft·lbf)	

TIGHTENING TORQUES

Item	Thread size	Q'ty	Tightening torque	Remarks
Headlight top cover and headlight side cover bolt	M6	2	10 Nm (1.0 m·kgf, 7.2 ft·lbf)	
Meter assembly 1 bolt	M8	2	10 Nm (1.0 m·kgf, 7.2 ft·lbf)	
Meter assembly 1 bracket bolt	M6	4	7 Nm (0.7 m·kgf, 5.1 ft·lbf)	
Headlight lower bracket and headlight side cover bolt	M6	2	10 Nm (1.0 m·kgf, 7.2 ft·lbf)	
Headlight lower bracket bolt	M6	2	7 Nm (0.7 m·kgf, 5.1 ft·lbf)	
Meter assembly 2 cover bolt	M6	1	7 Nm (0.7 m·kgf, 5.1 ft·lbf)	
Top cover bolt	M6	2	7 Nm (0.7 m·kgf, 5.1 ft·lbf)	
Top cover rubber damper bolt	M6	2	7 Nm (0.7 m·kgf, 5.1 ft·lbf)	
Top cover bracket bolt	M6	4	7 Nm (0.7 m·kgf, 5.1 ft·lbf)	
Top cover and main switch cover bolt	M6	2	7 Nm (0.7 m·kgf, 5.1 ft·lbf)	
Main switch cover bolt	M6	2	7 Nm (0.7 m·kgf, 5.1 ft·lbf)	
Intake duct assembly bolt	M6	6	7 Nm (0.7 m·kgf, 5.1 ft·lbf)	
Intake duct bracket bolt	M5	4	4 Nm (0.4 m·kgf, 2.9 ft·lbf)	
Meter assembly 2 bracket and main switch cover bolt	M6	2	7 Nm (0.7 m·kgf, 5.1 ft·lbf)	
Left rider footrest bolt	M8	2	28 Nm (2.8 m·kgf, 20 ft·lbf)	
Shift arm pinch bolt	M6	1	10 Nm (1.0 m·kgf, 7.2 ft·lbf)	
Shift rod locknut (shift arm side)	M6	1	7 Nm (0.7 m·kgf, 5.1 ft·lbf)	
Shift rod locknut (shift pedal side)	M6	1	7 Nm (0.7 m·kgf, 5.1 ft·lbf)	Left-hand thread
Sidestand bolt	M8	3	18 Nm (1.8 m·kgf, 13 ft·lbf)	
Dust cover bolt	M6	1	10 Nm (1.0 m·kgf, 7.2 ft·lbf)	
Final gear oil filler/breather assembly	M20	1	23 Nm (2.3 m·kgf, 17 ft·lbf)	
Final drive assembly nut	M10	4	42 Nm (4.2 m·kgf, 30 ft·lbf)	
Final gear oil check bolt	M6	1	10 Nm (1.0 m·kgf, 7.2 ft·lbf)	
Final gear oil drain bolt	M14	1	23 Nm (2.3 m·kgf, 17 ft·lbf)	
Ring gear bearing housing bolt	M12	2	85 Nm (8.5 m·kgf, 61 ft·lbf)	
Bearing retainer (ring gear) bolt	M6	6	10 Nm (1.0 m·kgf, 7.2 ft·lbf)	
Final drive case bolt	M8	6	19 Nm (1.9 m·kgf, 13 ft·lbf)	
Universal joint yoke nut	M20	1	130 Nm (13.0 m·kgf, 94 ft·lbf)	 Stake
Drive shaft end cap bolt	M6	1	9 Nm (0.9 m·kgf, 6.5 ft·lbf)	
Bearing retainer (final drive pinion gear)	M80	1	130 Nm (13.0 m·kgf, 94 ft·lbf)	Left-hand thread 
Baffle plate bolt	M6	3	7 Nm (0.7 m·kgf, 5.1 ft·lbf)	

TIGHTENING TORQUES

Item	Thread size	Q'ty	Tightening torque	Remarks
Dowel pin retainer bolt	M6	1	7 Nm (0.7 m·kgf, 5.1 ft·lbf)	

TIP

1. First, tighten the lower ring nut to approximately 52 Nm (5.2 m·kgf, 37 ft·lbf) with a torque wrench, then loosen the lower ring nut completely.
2. Retighten the lower ring nut to 18 Nm (1.8 m·kgf, 13 ft·lbf) with a torque wrench.

TIP

Front wheel axle pinch bolt

1. Insert the front wheel axle from the left side and tighten it with the flange bolt from the right side to 81 Nm (8.1 m·kgf, 59 ft·lbf).
2. In the order pinch bolt "2" → pinch bolt "1" → pinch bolt "2", tighten each bolt to 21 Nm (2.1 m·kgf, 15 ft·lbf) without performing temporary tightening.
3. Check that the left end of the front axle is flush with the front fork. If necessary, manually push the front axle or lightly tap it with a soft hammer until its end is flush with the front fork. However, if the surface of the front axle end is not parallel to the surface of the front fork, align a point on the outer edge of the axle with the fork, making sure that the axle does not protrude past the fork.
4. In the order pinch bolt "3" → pinch bolt "4" → pinch bolt "3", tighten each bolt to 21 Nm (2.1 m·kgf, 15 ft·lbf) without performing temporary tightening.

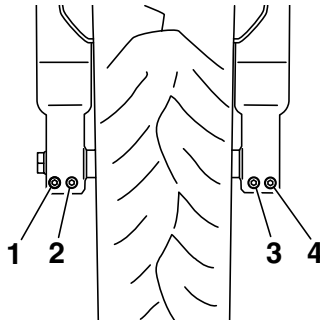

TIP

Rear wheel axle pinch bolt

- In the order pinch bolt "1" → pinch bolt "2" → pinch bolt "1", tighten each bolt to 21 Nm (2.1 m·kgf, 15 ft·lbf) without performing temporary tightening.

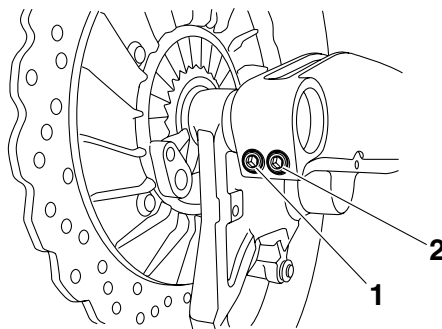

































LUBRICATION POINTS AND LUBRICANT TYPES

EAS20360





LUBRICATION POINTS AND LUBRICANT TYPES

EAS20370

ENGINE

Lubrication point	Lubricant
Oil seal lips	
O-rings	
Bearings	
Camshaft lobes and camshaft journals	
Valve lifters	
Valve stems (intake and exhaust)	
Valve stem ends (intake and exhaust)	
Crankshaft big ends	
Piston surfaces	
Piston pins	
Crankshaft journals	
Balancer shaft journals	
Camshaft sprockets and gears	
Decompression camshaft moving point	
Water pump impeller shaft	
Cooling system pipe O-rings	
Oil pump rotors (inner and outer)	
Oil strainer	
Starter idle gear shaft	
Starter clutch idle gear shaft	
Starter clutch gear	
Starter clutch	
Primary driven gear	
Long clutch push rod	
Short clutch push rod	
Ball	
Clutch boss nut thread and seat	
Transmission gears (wheel and pinion) and collars	
Main axle and drive axle	
Torque damper cam	
Middle drive pinion gear inner surface	
Middle drive pinion gear	
Middle driven pinion gear	

LUBRICATION POINTS AND LUBRICANT TYPES

Lubrication point	Lubricant
Shift forks and shift fork guide bars	
Shift drum assembly	
Shift shaft washer	
Stopper lever seat	
Ring gear thrust washer	Shaft drive gear oil (9079E-SH001-00)
Ring gear splines	
Ring gear bearing	Shaft drive gear oil (9079E-SH001-00)
Cylinder head cover mating surface	Yamaha bond No.1215 (Three bond No.1215®)
Cylinder head cover gasket	Yamaha bond No.1215 (Three bond No.1215®)
Crankcase mating surfaces	Yamaha bond No.1215 (Three bond No.1215®)
Stator assembly lead grommet	Yamaha bond No.1215 (Three bond No.1215®)

LUBRICATION POINTS AND LUBRICANT TYPES

EAS20380

CHASSIS

Lubrication point	Lubricant
Engine bracket bolt thread (front center, front right and front left)	
Engine mounting bolt thread (front and rear)	
Steering bearings and upper bearing cover lip	
Lower bearing dust seal lip	
Steering nut thread (upper and lower)	
Front wheel oil seal lips (right and left)	
Front wheel axle bolt	
Rear wheel axle thread	
Rear wheel oil seal lip	
Rear wheel drive hub mating surface	
O-ring (rear wheel)	
Tube guide (throttle grip) inner surface and throttle cables	
Brake lever pivot bolt and metal-to-metal moving parts	
Clutch lever pivot bolt and metal-to-metal moving parts	
Rear brake pedal pivoting point	
Passenger footrest pivoting point and ball	
Sidestand pivoting point and metal-to-metal moving parts	
Link and sidestand switch contact point	
Sidestand hook and link contact point	
Pivot shaft (right and left)	
Pivot shaft bearings and collars	
Pivot shaft oil seal lips	
Rear shock absorber assembly bearing and collar	
Rear shock absorber assembly spacer	
Relay arm bearings, spacer and oil seal lips	
Connecting arm bearings, spacer and oil seal lips	
Shift pedal pivoting point	
Seat lock lever pivoting point and collar	

LUBRICATION POINTS AND LUBRICANT TYPES

LUBRICATION SYSTEM CHART AND DIAGRAMS

EAS20390

LUBRICATION SYSTEM CHART AND DIAGRAMS

EAS20400

ENGINE OIL LUBRICATION CHART

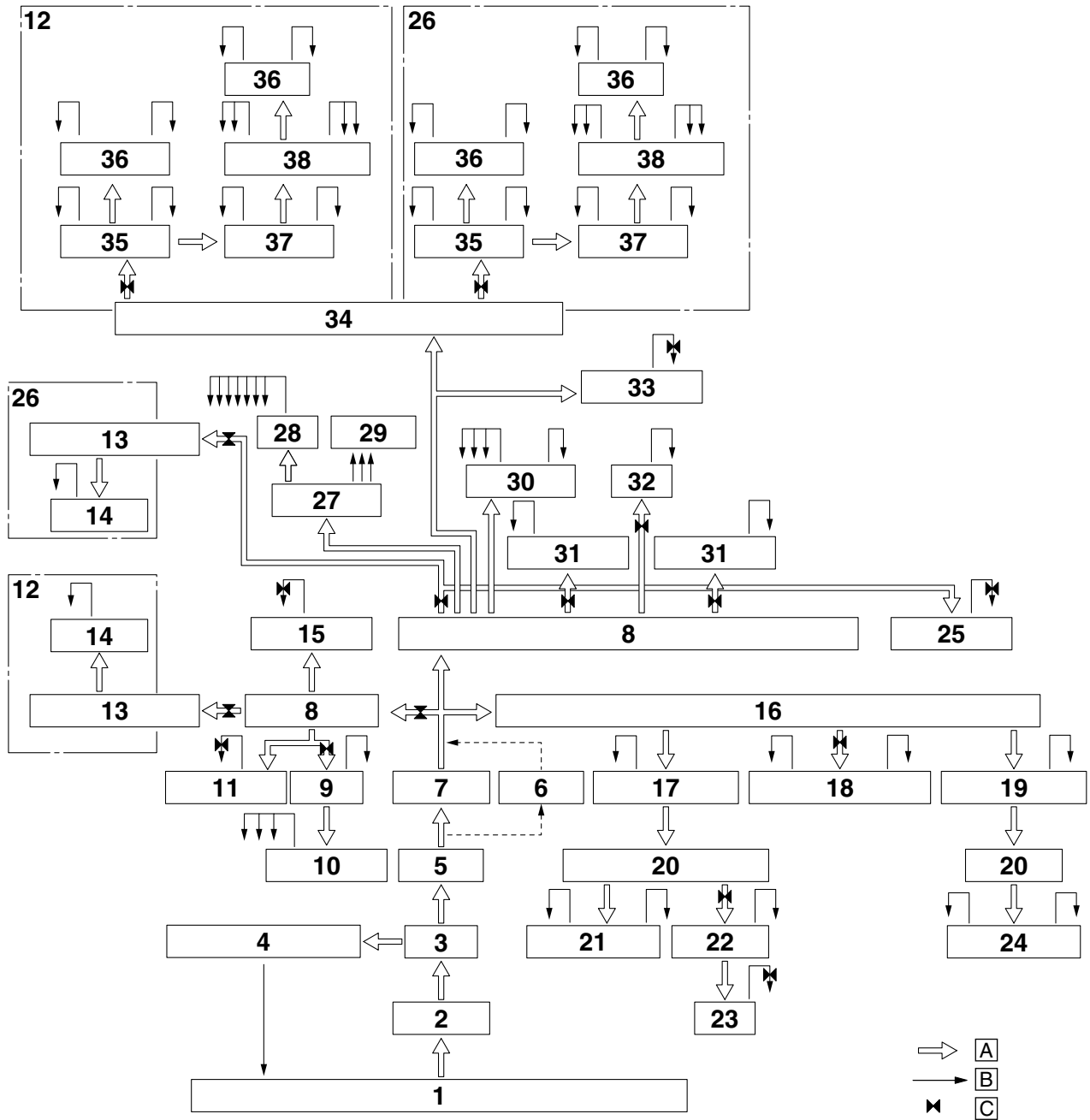

LUBRICATION SYSTEM CHART AND DIAGRAMS

1. Oil pan
2. Oil strainer
3. Oil pump
4. Relief valve
5. Oil cooler
6. Bypass valve
7. Oil filter cartridge
8. Crankcase oil gallery
9. Balancer
10. Balancer journal
11. Oil nozzle #4
12. Front cylinder head
13. Cylinder head
14. Timing chain tensioner
15. Oil nozzle #2
16. Main gallery
17. Crankshaft journal #1
18. Crankshaft journals #2/#3
19. Crankshaft journal #4
20. Crankshaft
21. Connecting rods #1/#2
22. Starter idle gear
23. AC magneto
24. Connecting rods #3/#4
25. Oil nozzle #3
26. Rear cylinder head
27. Oil pipe 3
28. Drive axle
29. Shift fork
30. Main axle
31. Shift fork guide bar
32. Middle driven pinion gear
33. Oil nozzle #1
34. Oil pipe
35. Intake camshaft
36. Camshaft journal
37. Exhaust camshaft
38. Camshaft cap
- A. Pressure feed
- B. Gravity feed
- C. Aperture

LUBRICATION SYSTEM CHART AND DIAGRAMS

EAS20410

LUBRICATION DIAGRAMS

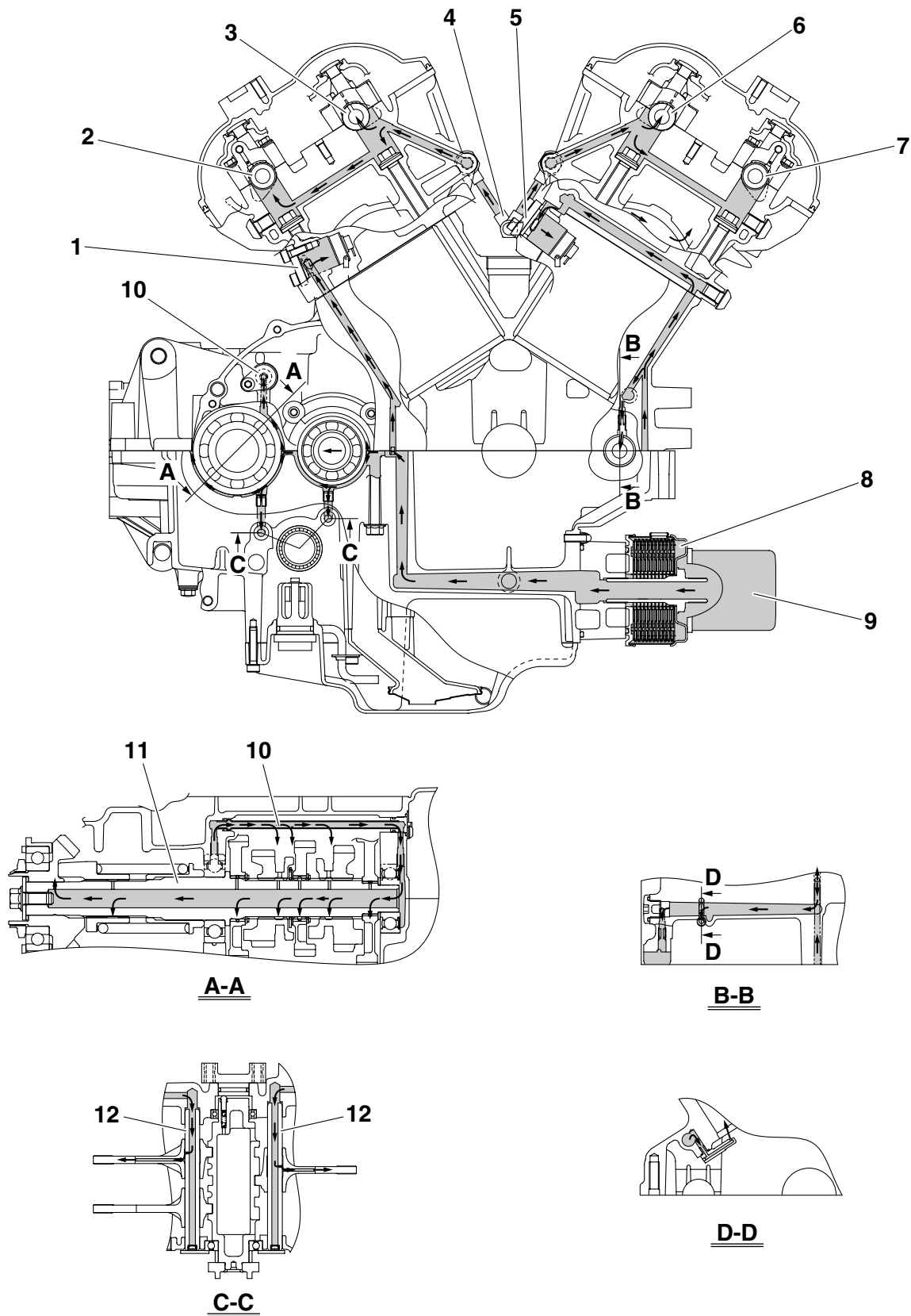

LUBRICATION SYSTEM CHART AND DIAGRAMS

1. Timing chain tensioner (rear cylinders)
2. Exhaust camshaft (rear cylinders)
3. Intake camshaft (rear cylinders)
4. Oil pipe 1
5. Timing chain tensioner (front cylinders)
6. Intake camshaft (front cylinders)
7. Exhaust camshaft (front cylinders)
8. Oil cooler
9. Oil filter cartridge
10. Oil pipe 3
11. Drive axle
12. Shift fork guide bar

LUBRICATION SYSTEM CHART AND DIAGRAMS

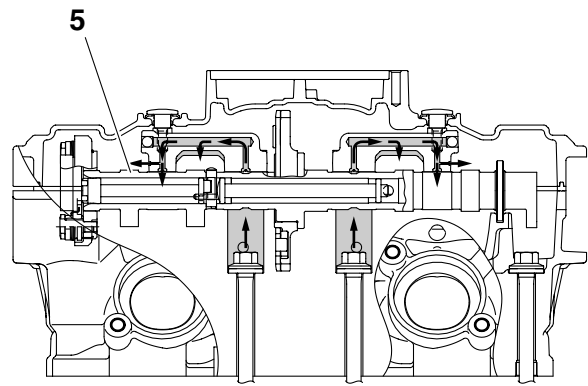
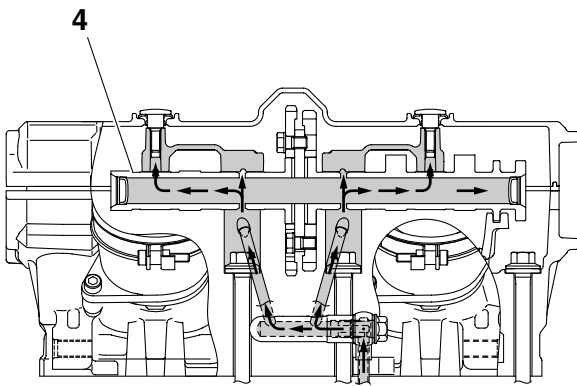
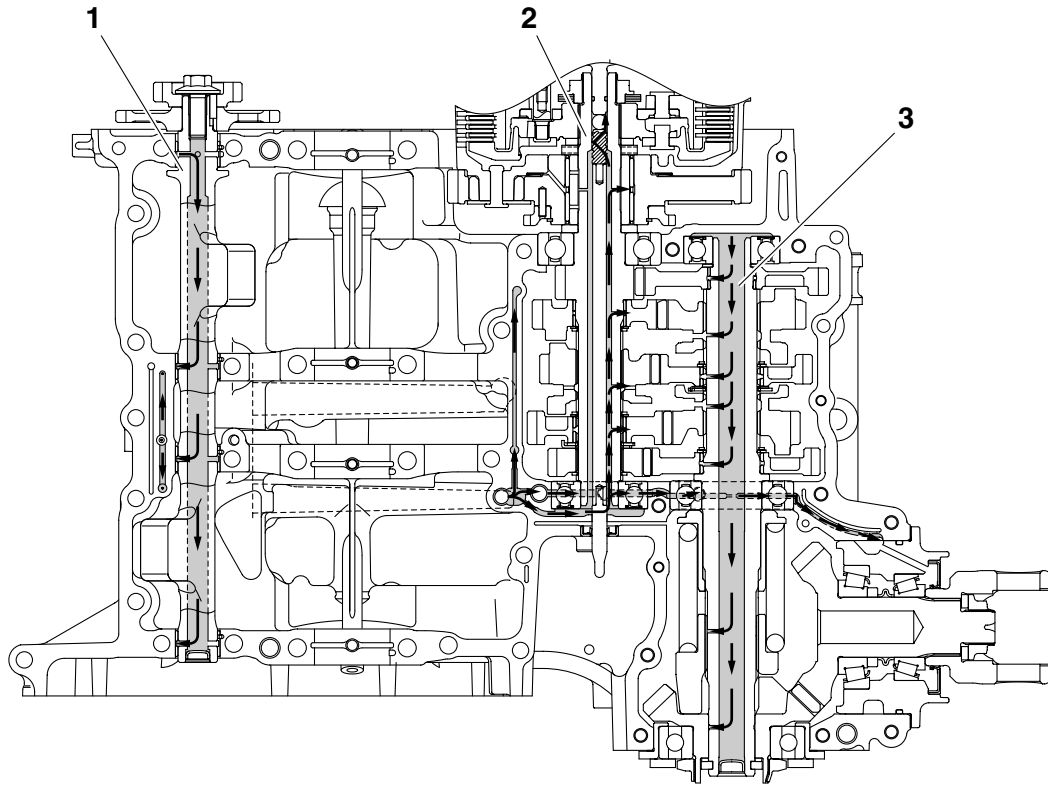

LUBRICATION SYSTEM CHART AND DIAGRAMS

1. Balancer shaft
2. Main axle
3. Drive axle
4. Intake camshaft
5. Exhaust camshaft

LUBRICATION SYSTEM CHART AND DIAGRAMS

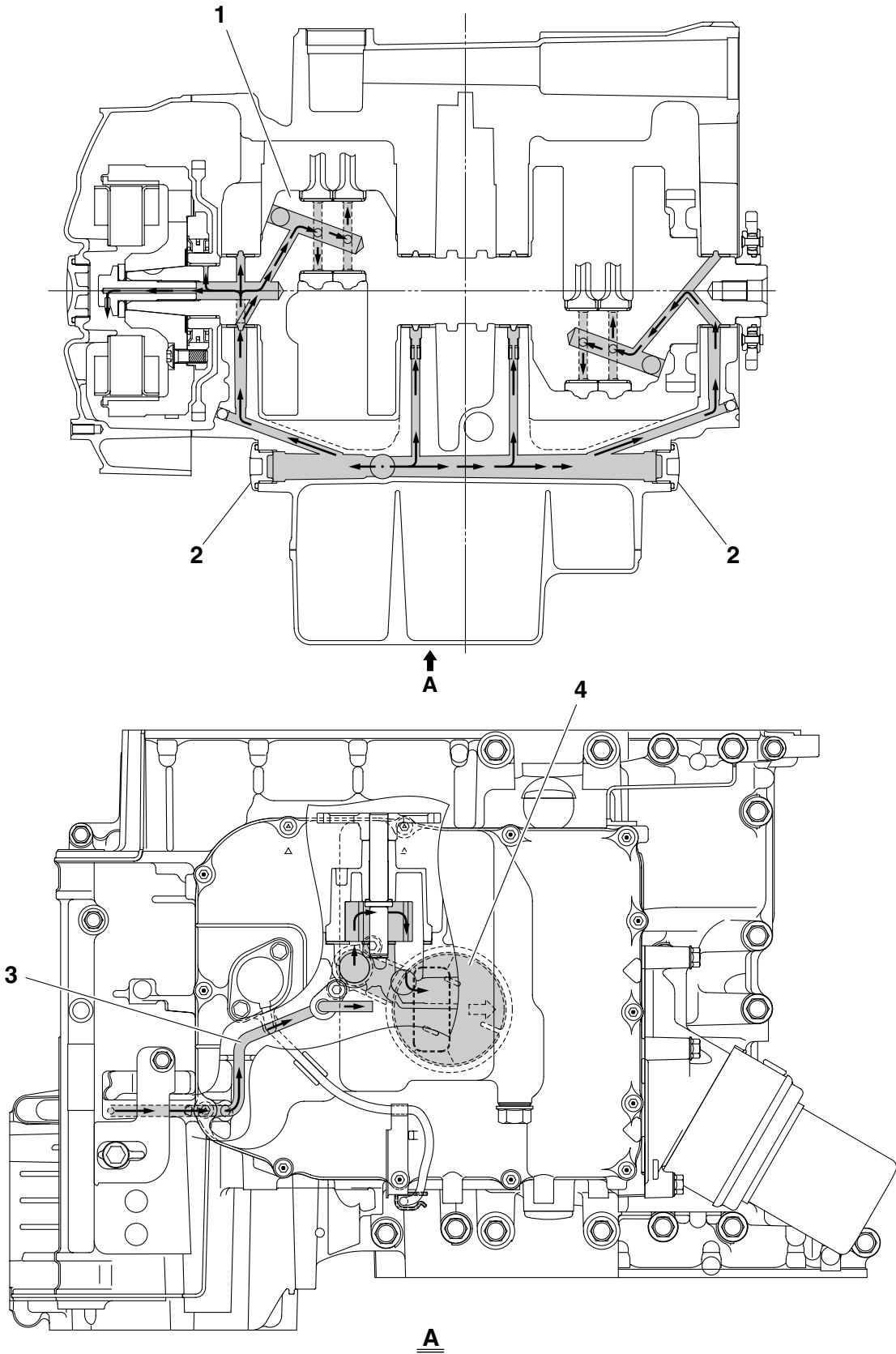

LUBRICATION SYSTEM CHART AND DIAGRAMS

1. Crankshaft
2. Main gallery bolt
3. Oil pipe 2
4. Oil strainer

LUBRICATION SYSTEM CHART AND DIAGRAMS

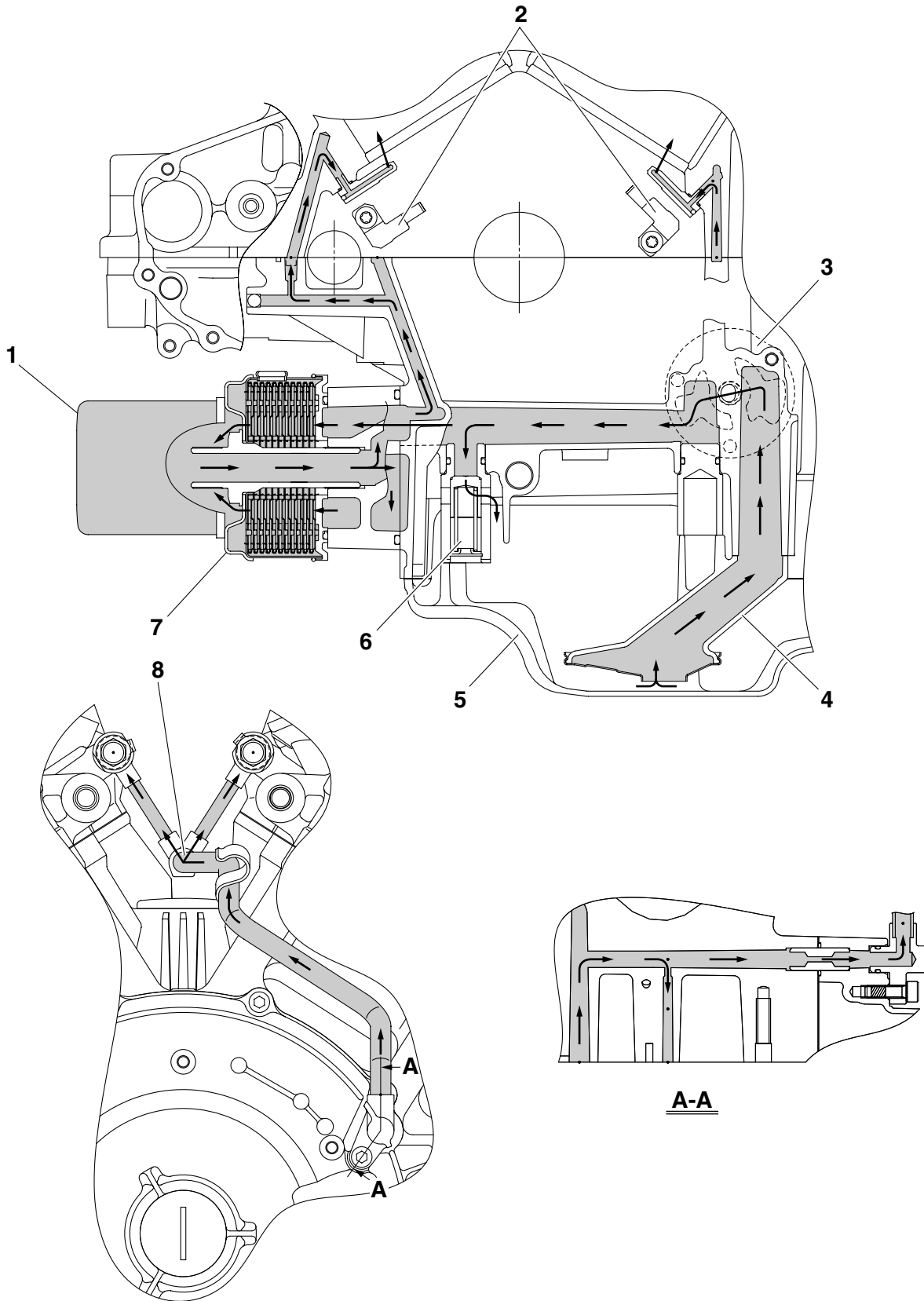

LUBRICATION SYSTEM CHART AND DIAGRAMS

1. Oil filter cartridge
2. Oil nozzle
3. Oil pump
4. Oil strainer
5. Oil pan
6. Relief valve assembly
7. Oil cooler
8. Oil pipe 1

COOLING SYSTEM DIAGRAMS

EAS20420

COOLING SYSTEM DIAGRAMS

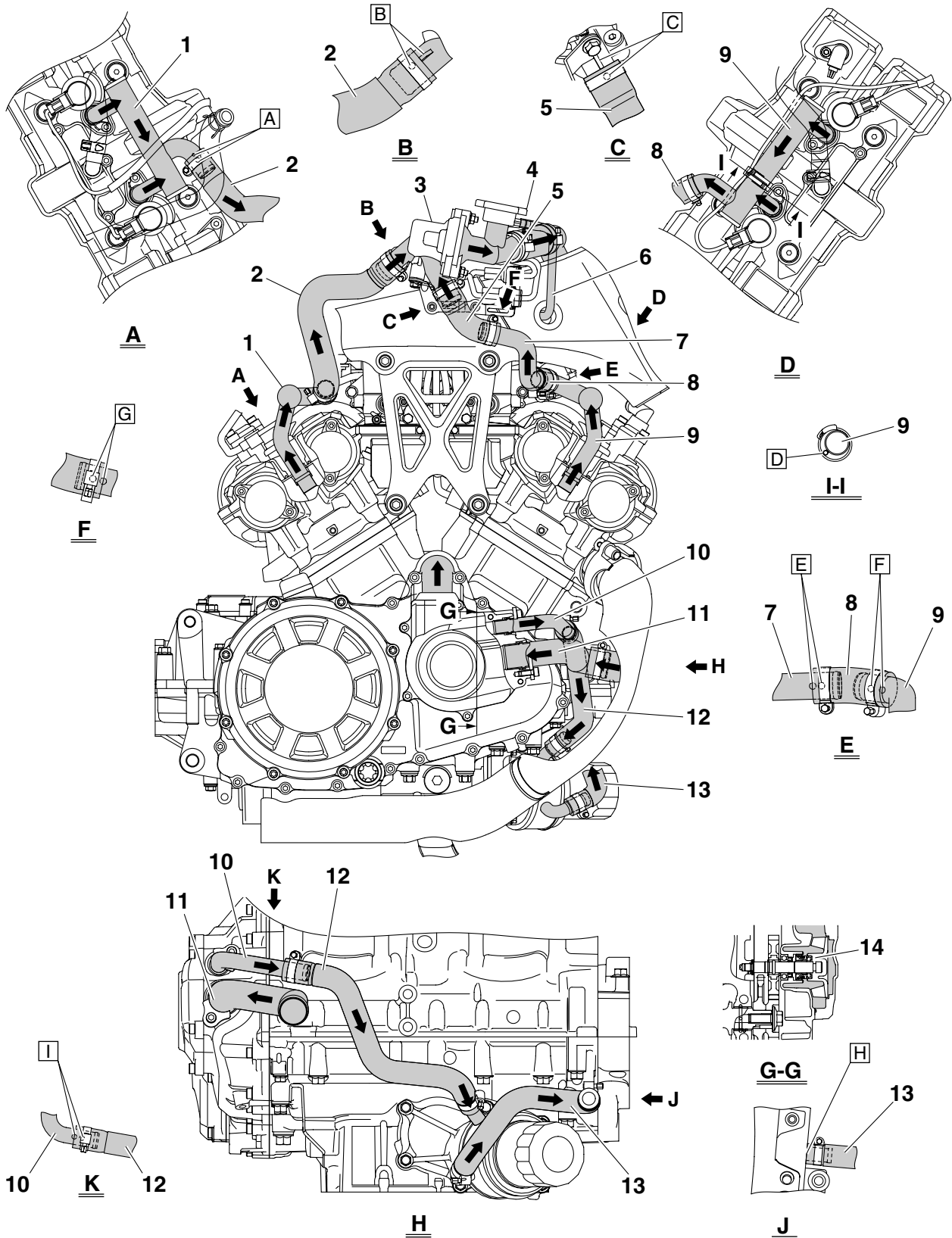

1. Thermostat inlet pipe (rear cylinder side)
 2. Thermostat inlet hose (rear cylinder side)
 3. Thermostat housing
 4. Radiator cap
 5. Thermostat inlet hose 2 (front cylinder side)
 6. Coolant reservoir hose
 7. Thermostat inlet pipe 2 (front cylinder side)
 8. Thermostat inlet hose 1 (front cylinder side)
 9. Thermostat inlet pipe 1 (front cylinder side)
 10. Water pump outlet pipe
 11. Water pump inlet pipe
 12. Oil cooler inlet hose
 13. Oil cooler outlet hose
 14. Impeller shaft
- A. Align the paint mark on the thermostat inlet pipe (rear cylinder side) with the paint mark on the thermostat inlet hose (rear cylinder side).
 - B. Align the paint mark on the thermostat inlet hose (rear cylinder side) with the rib on the thermostat housing.
 - C. Align the paint mark on the thermostat inlet hose 2 (front cylinder side) with the rib on the thermostat housing.
 - D. Align the tape on the ignition coil sub-wire harness 2 with the paint mark on the thermostat inlet pipe 1 (front cylinder side) and then fasten the ignition coil sub-wire harness 2 to the thermostat inlet pipe 1 (front cylinder side) with the plastic holder.
 - E. Align the paint mark on the thermostat inlet pipe 2 (front cylinder side) with the paint mark on the thermostat inlet hose 1 (front cylinder side).
 - F. Align the paint mark on the thermostat inlet pipe 1 (front cylinder side) with the paint mark on the thermostat inlet hose 1 (front cylinder side).
 - G. Align the paint mark on the thermostat inlet pipe 2 (front cylinder side) with the paint mark on the thermostat inlet hose 2 (front cylinder side).
 - H. Install the oil cooler outlet hose with its paint mark facing upward.
 - I. Align the paint mark on the water pump outlet pipe with the paint mark on the oil cooler inlet hose.

COOLING SYSTEM DIAGRAMS

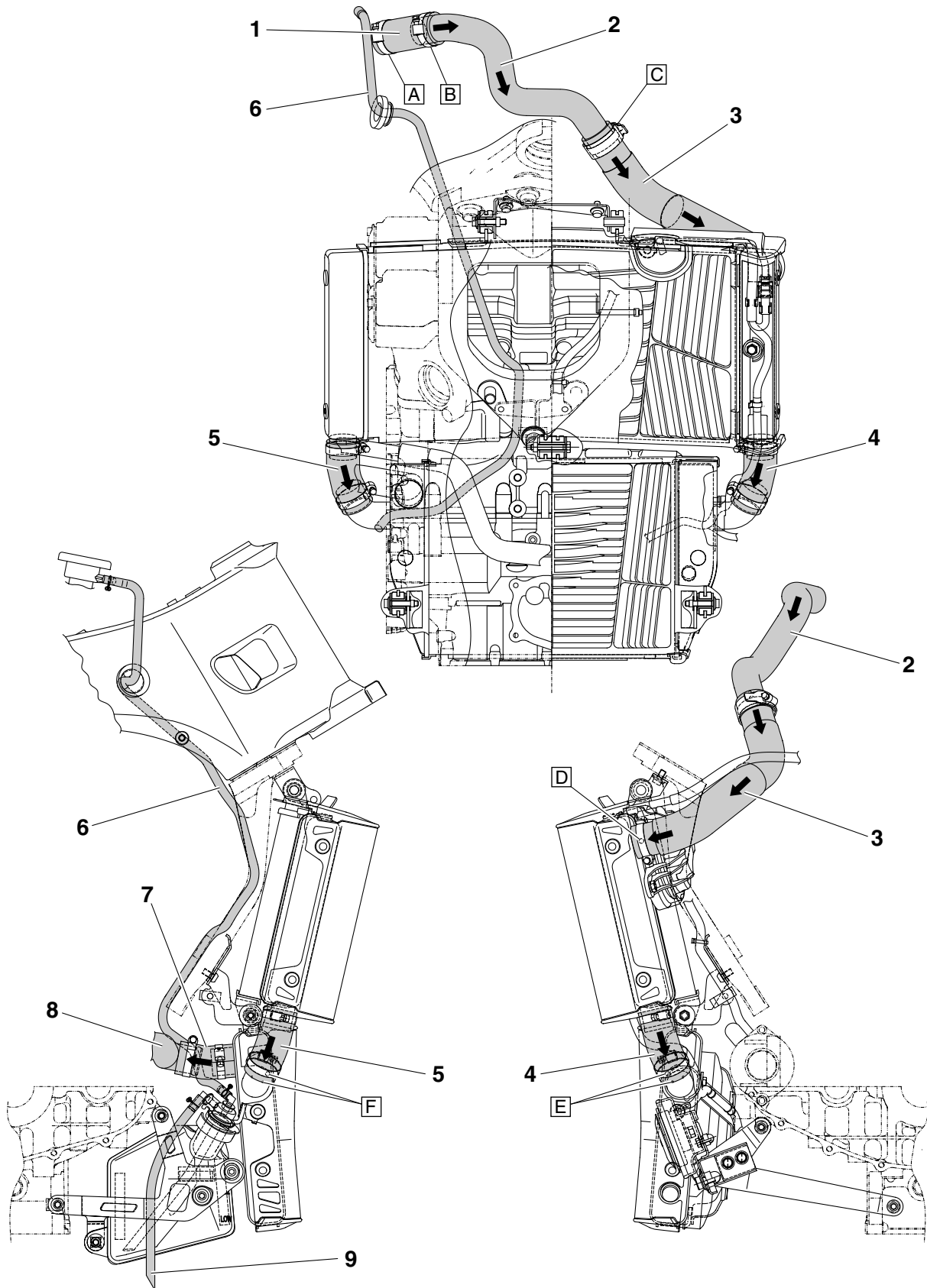

1. Thermostat outlet hose
2. Upper radiator inlet pipe
3. Upper radiator inlet hose
4. Left lower radiator inlet hose
5. Right lower radiator inlet hose
6. Coolant reservoir hose
7. Lower radiator outlet hose
8. Water pump inlet pipe
9. Coolant reservoir breather hose
- A. Align the paint mark on the thermostat outlet hose with the rib on the thermostat cover/radiator filler pipe.
- B. Align the paint mark on the upper radiator inlet pipe with the paint mark on the thermostat outlet hose.
- C. Align the paint mark on the upper radiator inlet pipe with the paint mark on the upper radiator inlet hose.
- D. Install the upper radiator inlet hose with its paint mark facing outward.
- E. Align the paint mark on the left lower radiator inlet hose with the front projection on the lower radiator joint.
- F. Align the paint mark on the right lower radiator inlet hose with the front projection on the lower radiator joint.

EAS20430

CABLE ROUTING

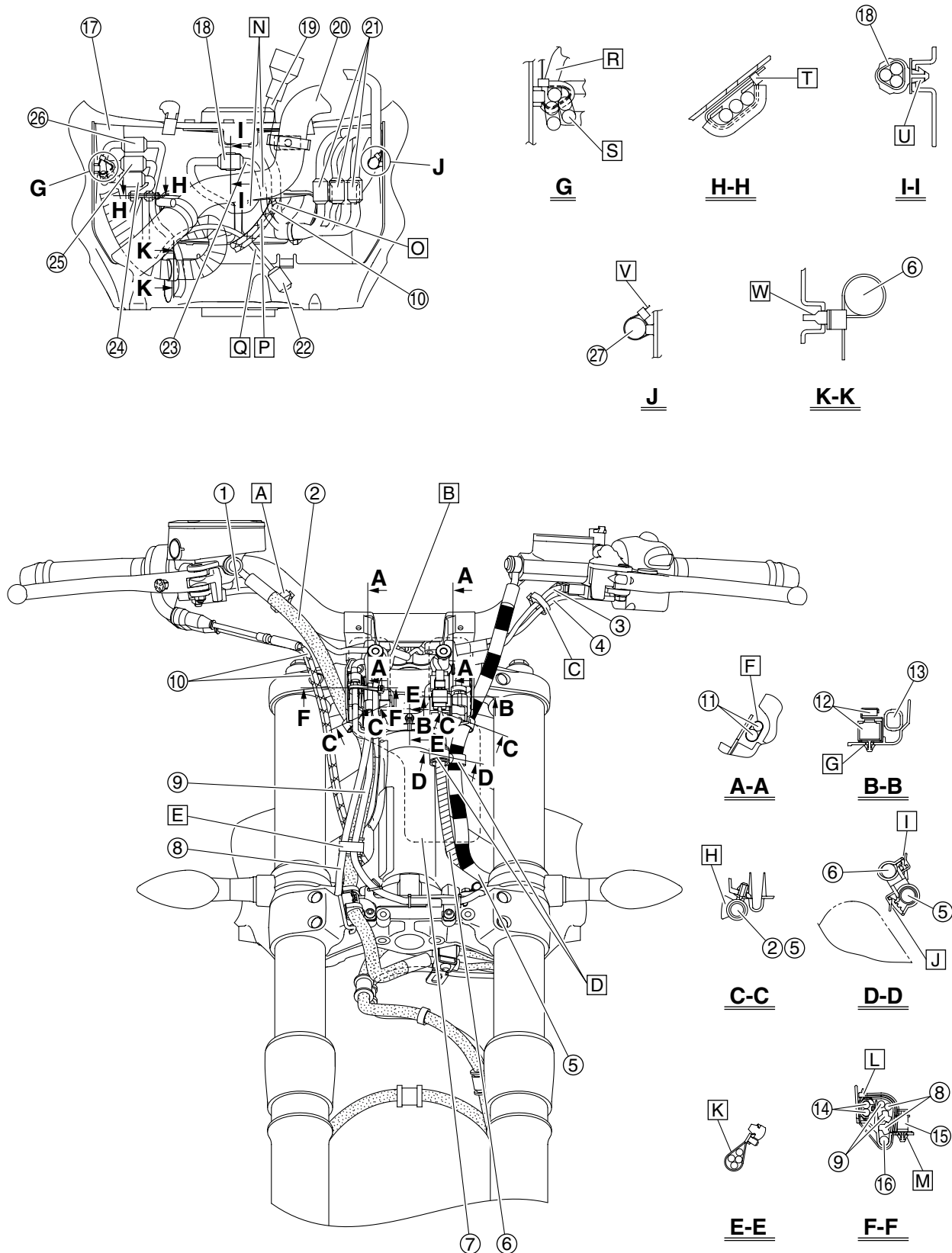

1. Front brake light switch lead
 2. Brake hose (front brake master cylinder to hydraulic unit)
 3. Clutch switch lead
 4. Left handlebar switch lead
 5. Clutch hose
 6. Wire harness
 7. Coupler cover
 8. Front right turn signal/position light lead
 9. Front left turn signal/position light lead
 10. Throttle cables
 11. Left and right handlebar switch leads
 12. Left handlebar switch couplers
 13. Intake air temperature sensor
 14. Right handlebar switch lead
 15. Right handlebar switch coupler
 16. SELECT/RESET button unit lead
 17. Wire harness mounting panel
 18. SELECT/RESET button unit coupler
 19. Meter assembly 2 lead
 20. Upper radiator inlet pipe
 21. Meter assembly 1 couplers
 22. Accelerator position sensor coupler
 23. SELECT/RESET button unit lead
 24. Cylinder identification sensor coupler
 25. Ignition coil sub-wire harness 2 coupler
 26. Front wheel sensor coupler
 27. Meter assembly 1 lead
- A. Fasten the right handlebar switch lead and front brake light switch lead with the holder. Face the catch of the holder forward.
 - B. Fit the SELECT/RESET button unit lead in the groove in the coupler holder.
 - C. Fasten the left handlebar switch lead and clutch switch lead with the holder. Face the catch of the holder forward.
 - D. Fasten the wire harness and grommet on the clutch hose with the holder.
 - E. Fasten the front left turn signal/position light lead, front right turn signal/position light lead, and grommet on the brake hose (front brake master cylinder to hydraulic unit) with the holder.
 - F. Route the left and right handlebar switch leads to the rear of the coupler holder.
 - G. Insert the projection on the left handlebar switch coupler into the hole in the coupler holder.
 - H. The catch of the holder may be facing to the left or right.
 - I. Face the catch of the holder outward.
 - J. Face the catch of the holder inward.
 - K. Fasten the front right turn signal/position light lead, front left turn signal/position light lead, right handlebar switch lead, and front brake light switch lead with the plastic band. The leads may be fastened in any order.
 - L. Point the end of the plastic locking tie forward, and then cut off the excess end of the tie to 2–5 mm (0.08–0.20 in).
 - M. Insert the projection on the right handlebar switch coupler into the hole in the coupler holder.
 - N. Route the SELECT/RESET button unit lead between the upper radiator inlet pipe and the wire harness mounting panel.
 - O. Route the throttle cables between the wire harness mounting panel and the meter assembly 2 lead.
 - P. Route the throttle cables between the wire harness mounting panel and the SELECT/RESET button unit lead.
 - Q. Route the accelerator position sensor lead between the throttle cables and the wire harness mounting panel.
 - R. Position the end of the plastic locking tie along the front frame. Make sure that the plastic locking tie does not protrude out of its protective tube.
 - S. Pass a plastic locking tie through the holes in the wire harness mounting panel, and then fasten the cylinder identification sensor lead, front wheel sensor lead, ignition coil sub-wire harness 2, starter motor lead, and meter assembly 2 lead with the tie. Align the plastic locking tie with the positioning tape on the starter motor lead. The leads may be fastened in any order.
 - T. Pass a plastic locking tie through the holes in the wire harness mounting panel, and then fasten the cylinder identification sensor lead, front wheel sensor lead, and ignition coil sub-wire harness 2 with the tie. Position the end of the plastic locking tie along the wire harness mounting panel, and then cut off the excess end of the tie to 1–5 mm (0.04–0.20 in).
 - U. Insert the projection on the SELECT/RESET button unit coupler into the hole in the wire harness mounting panel.
 - V. Fasten the meter assembly 1 lead at the split in the harness with a plastic locking tie. Point the end of the plastic locking tie toward the front frame, and then cut off the excess end of the tie to 1–5 mm (0.04–0.20 in).
 - W. Insert the projection on the plastic band into the hole in the wire harness mounting panel, and then fasten the wire harness with the band.

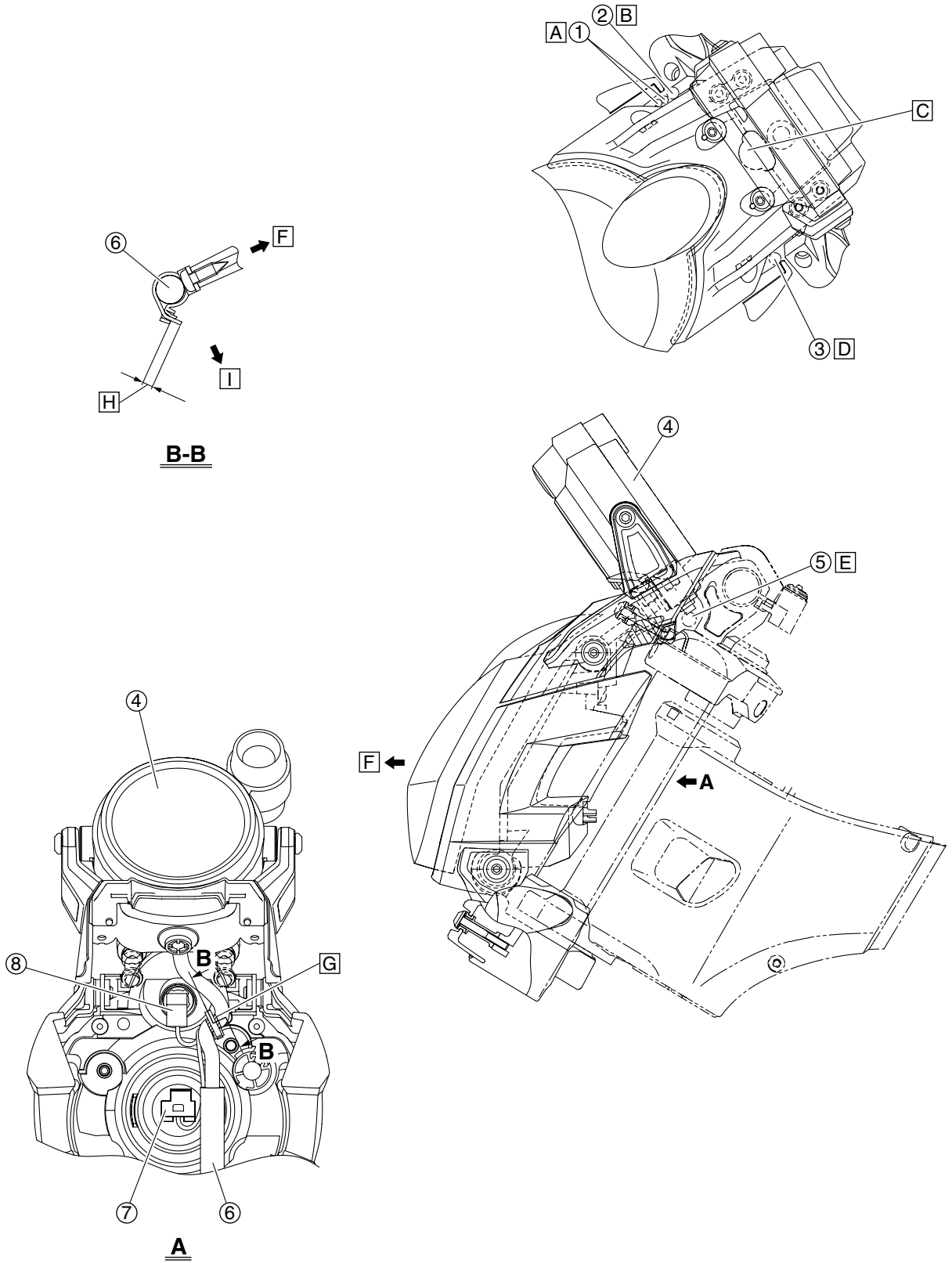

1. Throttle cables
2. Brake hose (front brake master cylinder to hydraulic unit)
3. Clutch hose
4. Meter assembly 1
5. Left handlebar switch lead
6. Meter assembly 1 lead
7. Headlight coupler
8. Auxiliary light coupler
- A. Route the throttle cables as shown in the illustration. When installing the headlight, make sure that the cables are not pinched.
- B. Route the brake hose (front brake master cylinder to hydraulic unit) as shown in the illustration. When installing the headlight, make sure that the hose is not pinched.
- C. Route the meter assembly 1 lead through the opening in the headlight top cover.
- D. Route the clutch hose as shown in the illustration. When installing the headlight, make sure that the hose is not pinched.
- E. Route the left handlebar switch lead as shown in the illustration. When installing the headlight, make sure that the lead is not pinched. Route the right handlebar switch lead in the same way on the right side of the vehicle.
- F. Forward
- G. Fasten the meter assembly 1 lead at the positioning tape with a plastic locking tie.
- H. Position the buckle of the plastic locking tie under the lead with its end pointing inward as shown in the illustration. Cut off the excess end of the plastic locking tie to 2–5 mm (0.08–0.20 in).
- I. Down

CABLE ROUTING

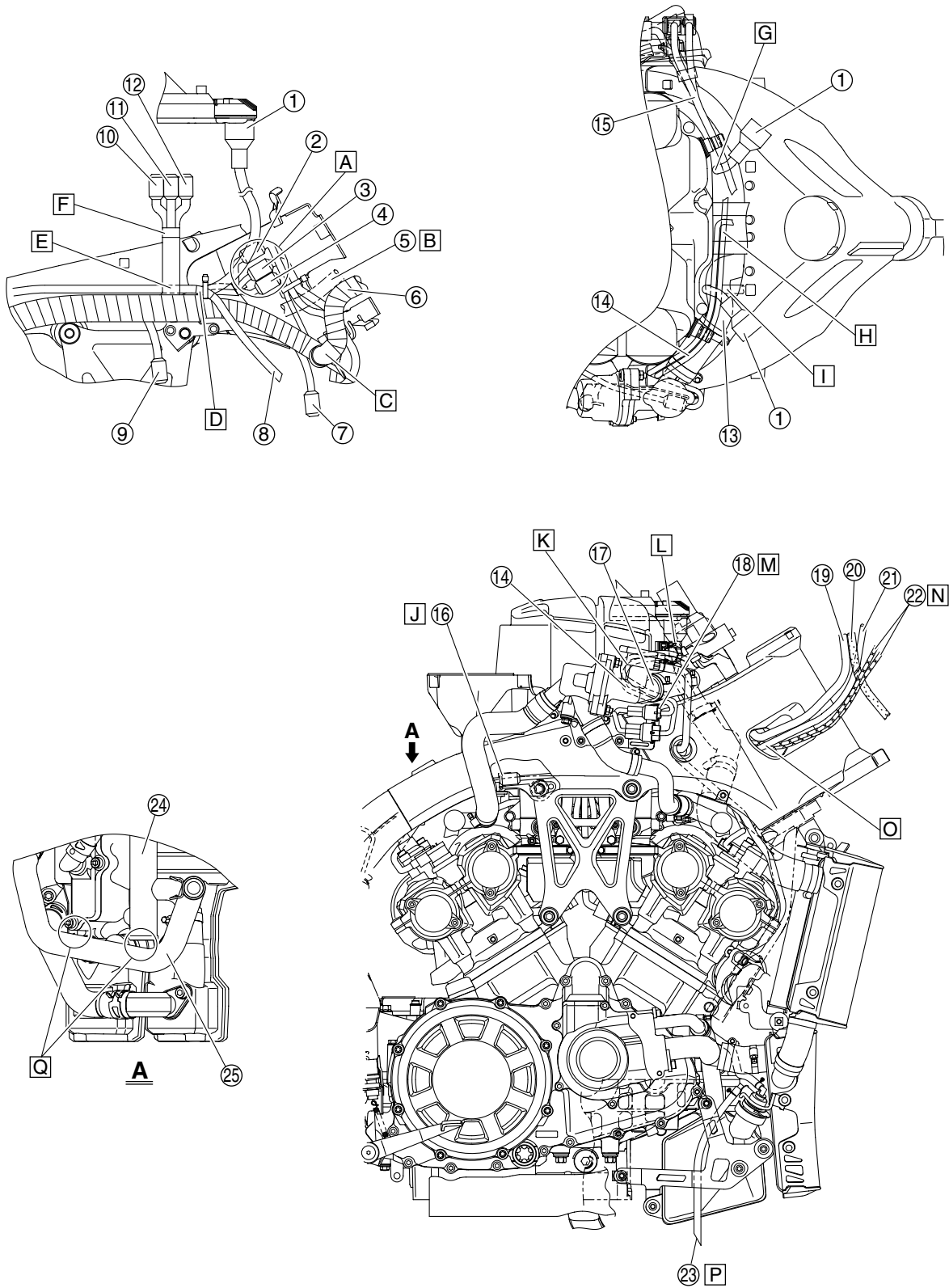

1. Meter assembly 2 coupler
 2. Ignition coil sub-wire harness 2 coupler
 3. Front wheel sensor coupler
 4. Cylinder identification sensor coupler
 5. Clutch hose
 6. Wire harness
 7. Accelerator position sensor coupler
 8. Starter motor lead
 9. Throttle position sensor coupler
 10. Radiator fan motor sub-wire harness coupler
 11. Air induction system solenoid coupler
 12. Atmospheric pressure sensor coupler
 13. Upper radiator inlet pipe
 14. Intake funnel servo motor lead
 15. Main switch leads
 16. Throttle servo motor coupler
 17. Thermostat outlet hose
 18. Intake funnel servo motor coupler
 19. SELECT/RESET button unit lead
 20. Brake hose (front brake master cylinder to hydraulic unit)
 21. Meter assembly 1 lead
 22. Throttle cables
 23. Coolant reservoir breather hose
 24. Thermostat inlet pipe (rear cylinders)
 25. Crankcase breather hose
- A. The ignition coil sub-wire harness 2 coupler, front wheel sensor coupler, and cylinder identification sensor coupler may be positioned in any order.
 - B. Route the clutch hose to the inside of ignition coil sub-wire harness 2, front wheel sensor lead, and cylinder identification sensor lead.
 - C. Insert the projection on the plastic band into the hole in the wire harness mounting panel, and then fasten the wire harness at the positioning tape with the band.
 - D. Fasten the starter motor lead, ignition coil sub-wire harness 2, front wheel sensor lead, and cylinder identification sensor lead with a plastic locking tie. Align the plastic locking tie with the positioning tape on the starter motor lead.
 - E. Route the starter motor lead between the frame and the leads (air induction system solenoid lead, atmospheric pressure sensor lead, and radiator fan motor sub-wire harness).
 - F. Make sure that the positioning tape on the radiator fan motor sub-wire harness is higher than the front frame as shown in the illustration.
 - G. Route the meter assembly 2 lead between the main switch leads and the air filter case.
 - H. Route the intake funnel servo motor lead above the sponge damper.
 - I. Route the meter assembly 2 lead to the front of the upper radiator inlet pipe, then to the rear of the intake funnel servo motor lead.
 - J. Install the throttle servo motor coupler onto the throttle servo motor coupler bracket so that the coupler is positioned between the bracket and the front frame.
 - K. Route the intake funnel servo motor lead between the air filter case and the thermostat assembly, and route the lead to the rear of thermostat outlet hose.
 - L. Fasten the intake funnel servo motor lead with the holder on the right side of the air filter case.
 - M. Insert the projection on the intake funnel servo motor coupler into the hole in the thermostat housing bracket.
 - N. Route the throttle cables to the outside of the brake hose (front brake master cylinder to hydraulic unit) and SELECT/RESET button unit lead.
 - O. Route the meter assembly 1 lead above the throttle cables.
 - P. Install the coolant reservoir breather hose so that the end of the hose is positioned as shown in the illustration.
 - Q. When routing the crankcase breather hose make sure that the hose is not pinched between the thermostat inlet pipe (rear cylinders) and the front frame or between the rear reed valve cover and the front frame.

CABLE ROUTING

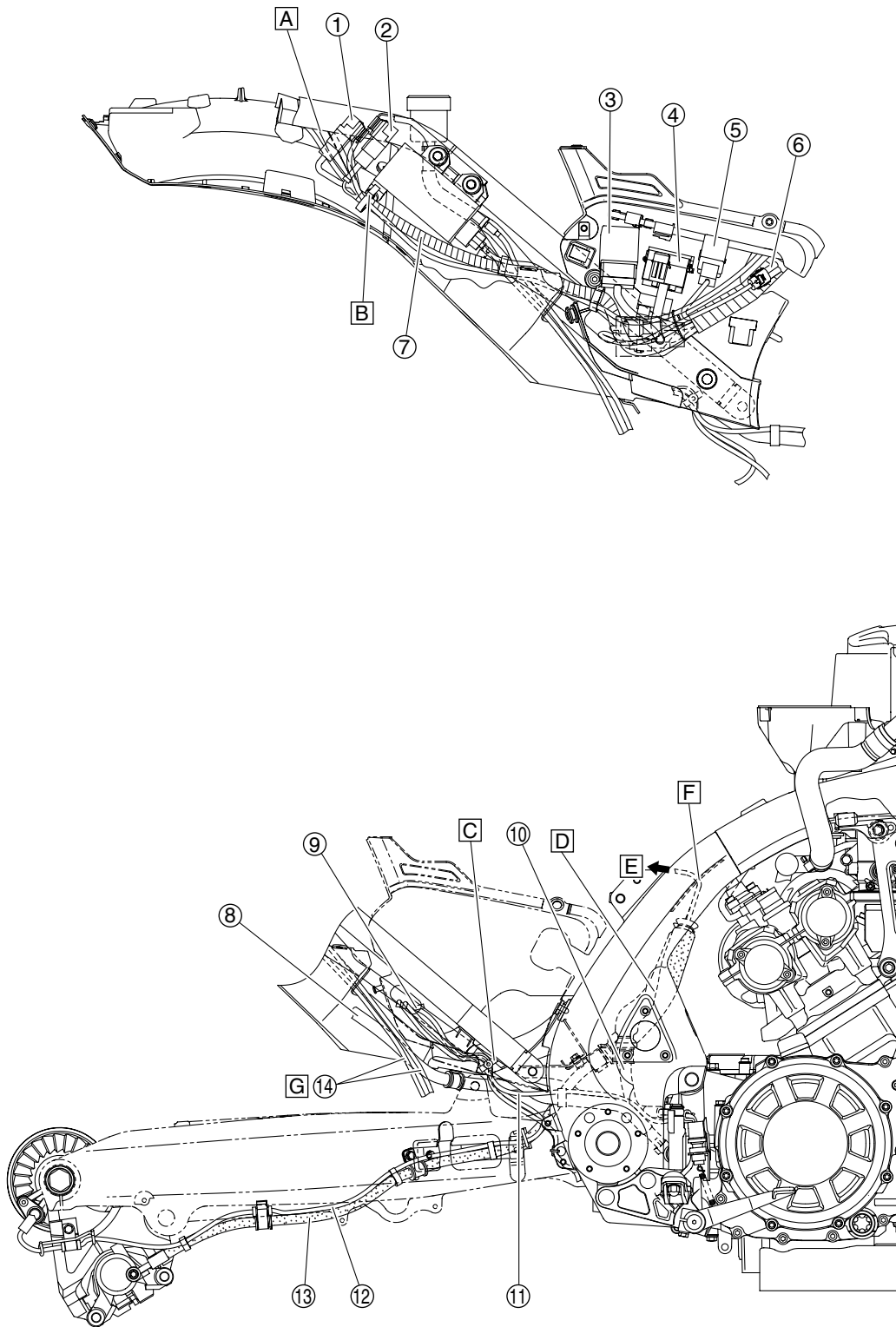

1. Radiator fan motor relay
2. Headlight relay
3. Relay unit
4. Fuse box 1
5. Turn signal/hazard relay
6. Rear wheel sensor coupler
7. Wire harness
8. Gas cylinder hose (rear shock absorber assembly)
9. O₂ sensor lead
10. Brake hose (rear brake master cylinder to hydraulic unit)
11. Rear brake light switch lead
12. Rear wheel sensor lead
13. Brake hose (hydraulic unit to rear brake caliper)
14. EXUP cables
 - A. Route the rectifier/regulator leads, rear left turn signal light lead, rear right turn signal light lead, tail/brake light lead, and license plate light lead between the rear frame and mud guard 1.
 - B. Fasten the wire harness at the split in the harness with the holder. Face the catch of the holder outward.
 - C. Insert the projection on the plastic locking tie into the hole in the right side cover from the inside, and then fasten the rear brake light switch lead, rear wheel sensor lead, and O₂ sensor lead with the tie.
 - D. Cross the brake hose (hydraulic unit to rear brake caliper) in front of the brake hose (rear brake master cylinder to hydraulic unit).
 - E. To hydraulic unit assembly
 - F. Route the brake hose (hydraulic unit to rear brake caliper) and brake hose (rear brake master cylinder to hydraulic unit) through the cutout in the fuel tank protector.
 - G. Route the EXUP cables to the outside of the gas cylinder hose (rear shock absorber assembly).

CABLE ROUTING

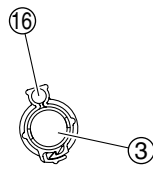
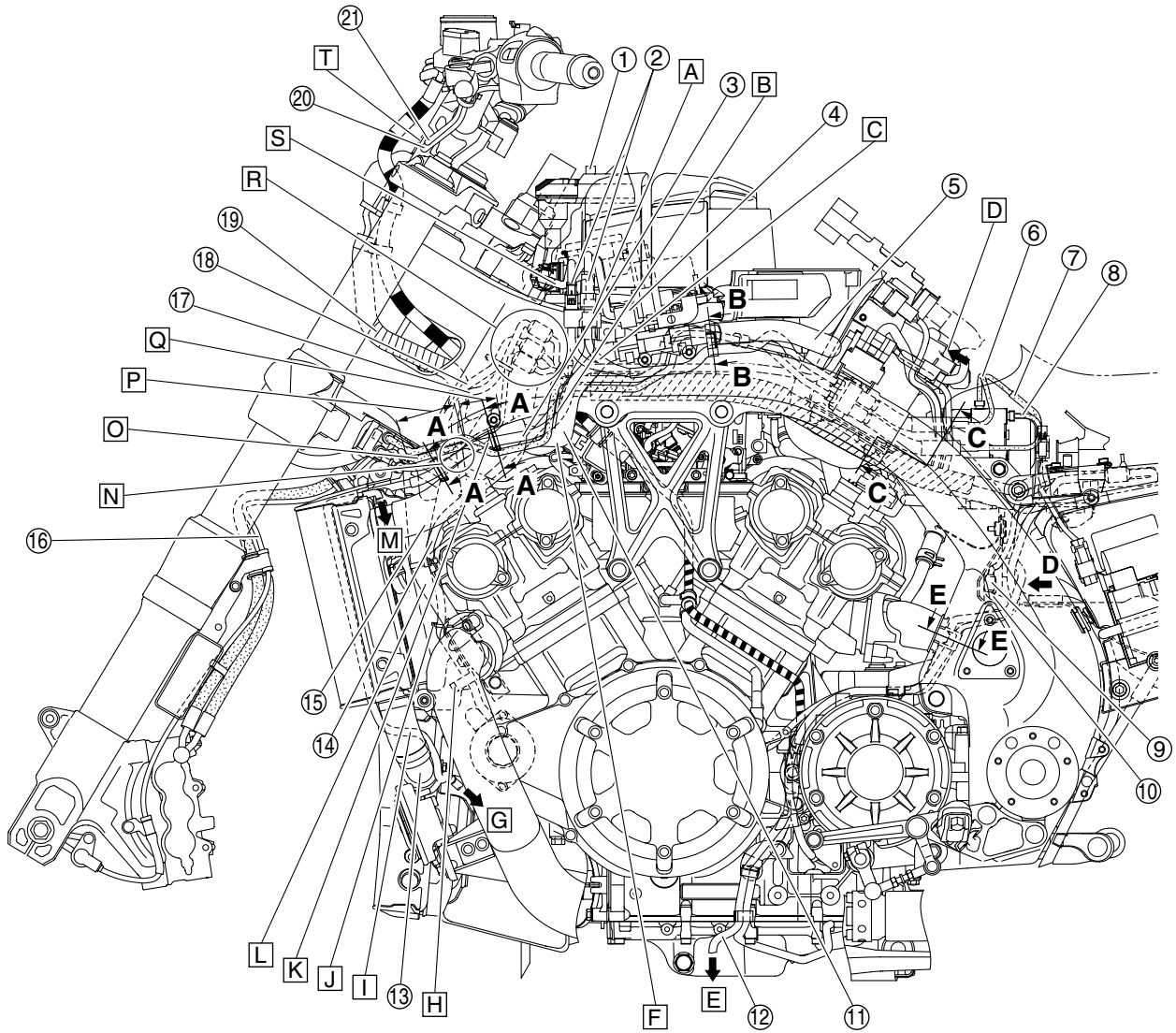

A-A

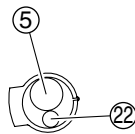

B-B

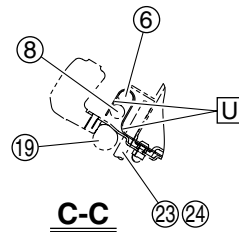

C-C

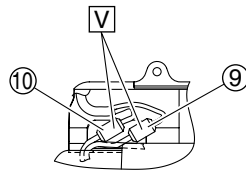

D

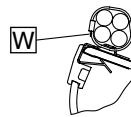

E-E

1. Meter assembly 2
2. Main switch couplers
3. Radiator fan motor sub-wire harness
4. Air induction system solenoid coupler
5. Air induction system hose (air cut-off valve to rear reed valve cover)
6. Brake hose (hydraulic unit to left front brake caliper)
7. Brake hose (hydraulic unit to rear brake caliper)
8. Brake hose (front brake master cylinder to hydraulic unit)
9. Crankshaft position sensor coupler
10. Oil level switch coupler
11. Air induction system hose (air cut-off valve to front reed valve cover)
12. Sidestand switch lead
13. Left lower radiator inlet hose
14. Starter motor lead
15. Upper radiator inlet hose
16. Front wheel sensor lead
17. Ignition coil sub-wire harness 2
18. Cylinder identification sensor lead
19. Wire harness
20. Left handlebar switch lead
21. Clutch switch lead
22. Main switch lead
23. Main fuse lead
24. Starter relay lead
- A. Fit the main switch coupler rubber holder onto the tab on the air cut-off valve bracket.
- B. Route the radiator fan motor sub-wire harness between the brake hoses and the air induction system hose (air cut-off valve to front reed valve cover).
- C. Route the main switch leads to the outside of the air induction system hose (air cut-off valve to front reed valve cover).
- D. To positive battery terminal
- E. To sidestand switch
- F. Route the air induction system hose (air cut-off valve to front reed valve cover) to the rear of upper radiator inlet hose.
- G. To main radiator fan motor
- H. Fasten the starter motor lead with the holder. Face the catch of the holder forward.
- I. Route the radiator fan motor sub-wire harness to the inside of the left lower radiator inlet hose.
- J. Fasten the starter motor lead to the upper/lower radiator bracket with a plastic locking tie.
- K. Route the radiator fan motor sub-wire harness above upper radiator inlet hose, under the brake hose (hydraulic unit to left front brake caliper) and brake hose (front brake master cylinder to hydraulic unit), and to the inside of the air induction system hose (air cut-off valve to front reed valve cover).
- L. When routing the starter motor lead, make sure that the lead is not pinched between the upper radiator and the engine.
- M. To sub radiator fan motor
- N. Route ignition coil sub-wire harness 2, front wheel sensor lead, and cylinder identification sensor lead above upper radiator inlet hose.
- O. Route the radiator fan motor sub-wire harness to the inside of the brake hose (hydraulic unit to left front brake caliper) and brake hose (front brake master cylinder to hydraulic unit).
- P. Fasten the front wheel sensor lead and radiator fan motor sub-wire harness with the holder. Position the holder in the center of the area shown in the illustration.
- Q. Fasten the front wheel sensor lead and radiator fan motor sub-wire harness with the holder. Position the holder in the area shown in the illustration.
- R. Position the ignition coil sub-wire harness 2 coupler, front wheel sensor coupler, and cylinder identification sensor coupler as shown in the illustration. The couplers may be positioned in any order.
- S. Fasten the main switch leads with the holder on the left side of the air filter case.
- T. Route the left handlebar switch lead and clutch switch lead between the left handlebar holder and the coupler holder.
- U. Wrap the battery box heat shield around the brake hose (front brake master cylinder to hydraulic unit) and brake hose (hydraulic unit to left front brake caliper) so that it hangs down as shown in the illustration. Be sure to position the battery box heat shield between the brake hoses and the leads (main fuse and starter relay)
- V. Insert the projections on the oil level switch coupler and crankshaft position sensor coupler into the holes in the fuel tank protector.
- W. Fasten the oil level switch lead, crankshaft position sensor lead, sidestand switch lead, stator coil lead, and gear position switch lead with a plastic locking tie. Point the end of the plastic locking tie forward, and then cut off the excess end of the tie to 1–5 mm (0.04–0.20 in).

CABLE ROUTING

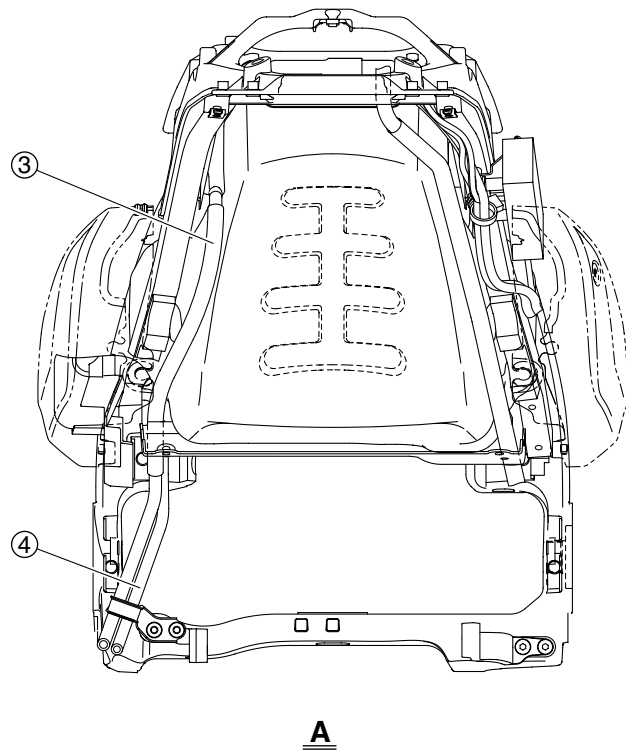
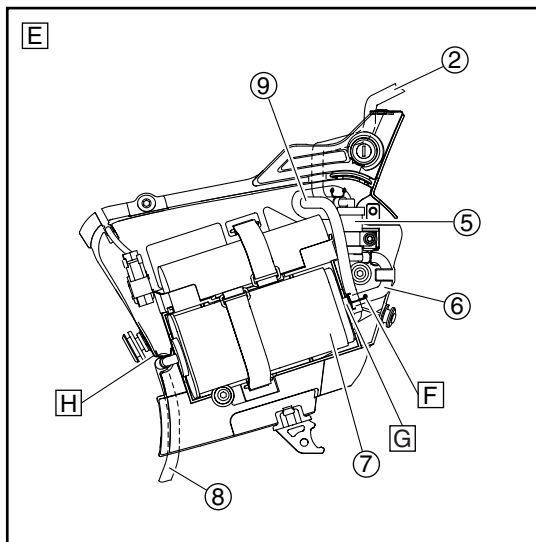
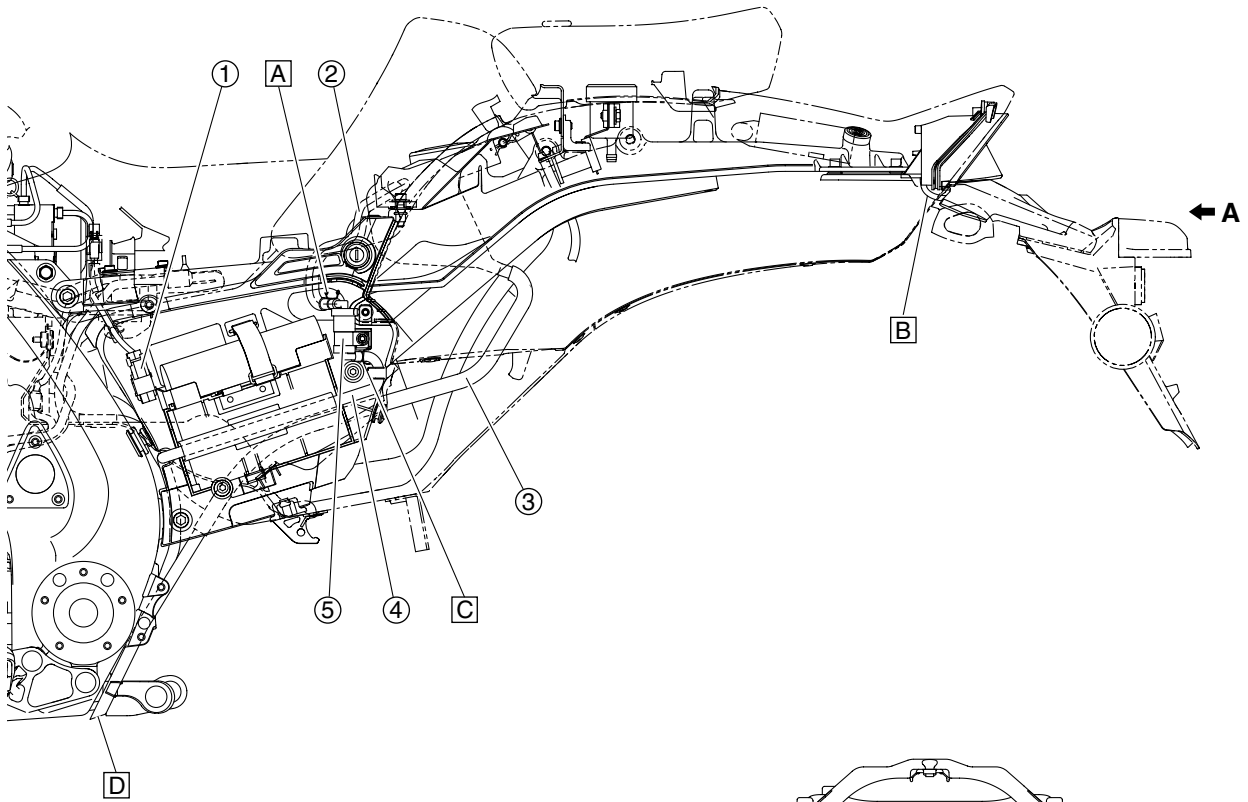

1. ABS test coupler
2. Fuel tank breather hose (fuel tank to rollover valve)
3. Fuel overflow hose
4. Fuel tank breather hose
5. Rollover valve
6. Fuel tank breather hose (rollover valve to canister) (for California only)
7. Canister (for California only)
8. Canister breather hose (for California only)
9. Canister purge hose (for California only)
- A. Install the hose onto the hose fitting of the rollover valve, making sure that the hose contacts the valve. Position the hose clamp 5 mm (0.20 in) from the end of the hose, making sure to point the ends of the clamp upward.
- B. Do not allow the rear left turn signal light lead, rear right turn signal light lead, tail/brake light lead, or license plate light lead to hang down in this area.
- C. Install the hose onto the hose fitting of the rollover valve, making sure that the hose contacts the valve. Position the hose clamp 5 mm (0.20 in) from the end of the hose, making sure to point the ends of the clamp outward.
- D. Install the fuel overflow hose, fuel tank breather hose, and canister breather hose (for California only) so that the end of each hose is positioned as shown in the illustration.
- E. For California only
- F. Install the hose onto the hose fitting of the canister up to the bend in the fitting. Position the hose clamp 5 mm (0.20 in) from the end of the hose, making sure to point the ends of the clamp rearward.
- G. Install the hose onto the hose fitting of the canister, making sure that the hose contacts the canister. Position the hose clamp 5 mm (0.20 in) from the end of the hose, making sure to point the ends of the clamp inward.
- H. Install the hose onto the hose fitting of the canister up to the bend in the fitting. Position the hose clamp 5 mm (0.20 in) from the end of the hose, making sure to point the ends of the clamp upward.

CABLE ROUTING

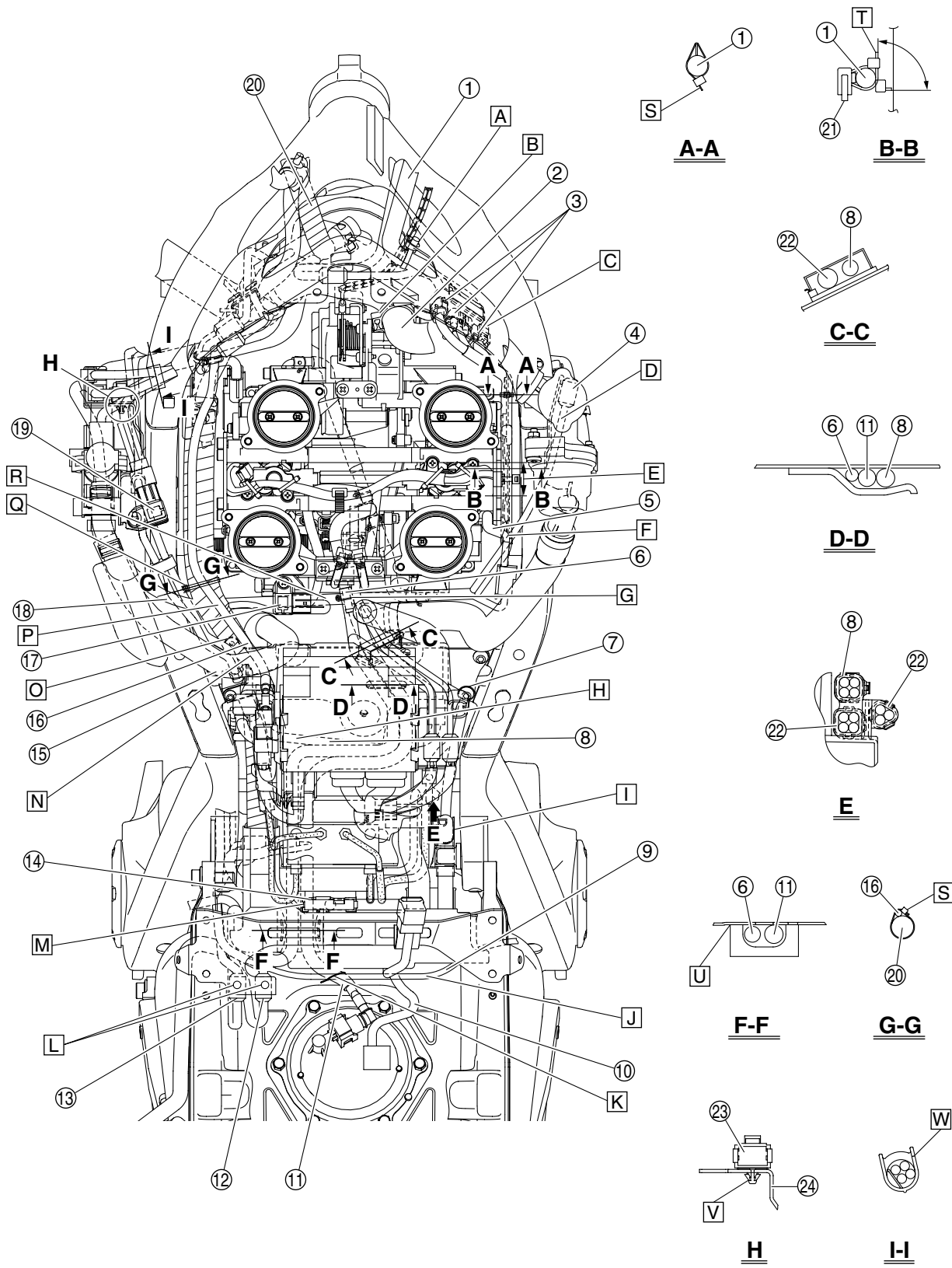

1. Meter assembly 1 lead
 2. Upper radiator inlet pipe
 3. Meter assembly couplers
 4. Intake funnel servo motor coupler
 5. Throttle servo motor lead
 6. Canister purge hose (for California only)
 7. Frame ground
 8. Ignition coil sub-wire harness 1
 9. Stator coil lead
 10. Fuel pump lead
 11. Fuel hose
 12. Sidestand switch coupler
 13. Gear position switch coupler
 14. Fuse box 2
 15. Air induction system hose (air cut-off valve to rear reed valve cover)
 16. Starter motor lead
 17. Intake air pressure sensor
 18. Main switch lead
 19. Atmospheric pressure sensor
 20. Wire harness
 21. Throttle bodies
 22. Sub-wire harness
 23. Radiator fan motor sub-wire harness coupler
 24. Air cut-off valve bracket
- A. Insert the projection on the plastic locking tie into the hole in the wire harness mounting panel, and then fasten the meter assembly 1 lead with the tie.
 - B. Fasten the upper radiator inlet pipe with the holder. Face the catch of the holder to the left.
 - C. Fit the meter assembly coupler rubber holder onto the tab on the wire harness mounting panel.
 - D. Route the intake funnel servo motor lead between the thermostat assembly and the front frame.
 - E. Install the plastic locking tie holder onto the throttle bodies in the area shown in the illustration.
 - F. Route the intake funnel servo motor lead under the throttle servo motor lead.
 - G. Point the ends of the hose clamp for the canister purge hose to the left. (for California only)
 - H. Route ignition coil sub-wire harness 1 under the fuel hose and canister purge hose (for California only).
 - I. Position the wire harness L-shaped guide between the hydraulic unit assembly box and the rear frame.
 - J. Route the stator coil lead above the fuel hose and fuel pump lead.
 - K. Fasten the stator coil lead and fuel hose with a plastic locking tie. Position the end of the plastic locking tie along the fuel tank. Do not cut off the excess end of the plastic locking tie.
 - L. Insert the projections on the sidestand switch coupler and gear position switch coupler into the holes in the rider seat bracket from below.
 - M. Fit fuse box 2 into the holder on the hydraulic unit assembly box.
 - N. Route the starter relay lead under the air induction system hose (air cut-off valve to rear reed valve cover).
 - O. Insert the projection on the wire harness holder into the hole in the battery box bracket.
 - P. Route the starter motor lead to the inside of the main switch lead.
 - Q. Fasten the wire harness and starter relay lead with a plastic locking tie at the location shown in the illustration.
 - R. Route the wire harness under the intake air pressure sensor, fuel hose, and canister purge hose (for California only).
 - S. Point the end of the plastic locking tie outward, and then cut off the excess end of the tie to 1–5 mm (0.04–0.20 in).
 - T. Position the end of the plastic locking tie within the range shown in the illustration, and then cut off the excess end of the tie to 0–3 mm (0.00–0.12 in).
 - U. Make sure that the rubber damper contacts the wire harness guide.
 - V. Insert the projection on the radiator fan motor sub-wire harness coupler into the hole in the air cut-off valve bracket.
 - W. Fasten the main switch leads, air induction system solenoid lead, and radiator fan motor sub-wire harness with the holder. Align the holder with the white tape on the radiator fan motor sub-wire harness.

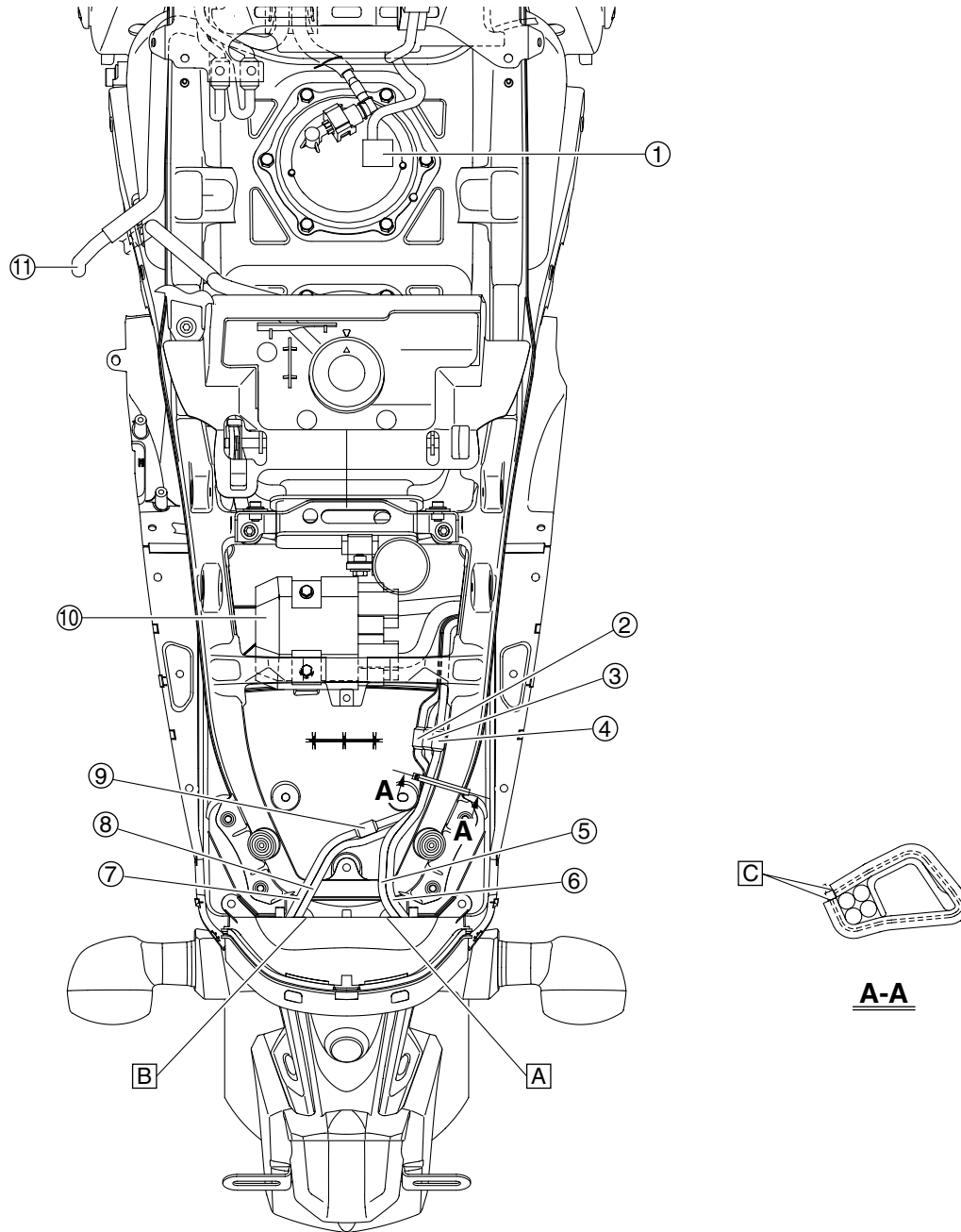

1. Fuel pump coupler
2. Rear left turn signal light coupler
3. Tail/brake light coupler
4. Rear right turn signal light coupler
5. Tail/brake light lead
6. Rear right turn signal light lead
7. License plate light lead
8. Rear left turn signal light lead
9. License plate light coupler (yellow)
10. Rectifier/regulator
11. Canister purge hose (for California only)
 - A. Route the tail/brake light lead and rear right turn signal light lead through the hole in the mud guard rubber cover.
 - B. Route the license plate light lead and rear left turn signal light lead through the hole in the mud guard rubber cover.
 - C. Make sure that the plastic locking tie does not protrude out of its protective tube.

CABLE ROUTING

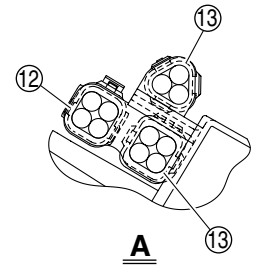
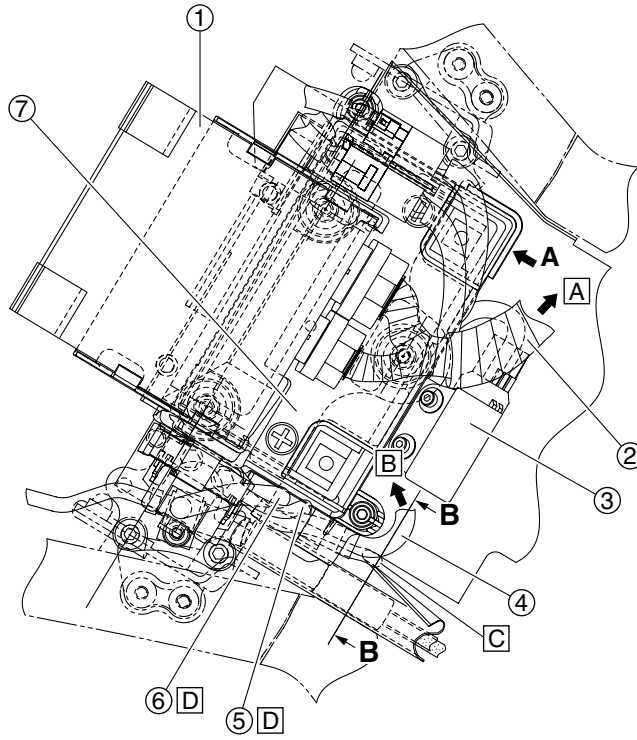

A

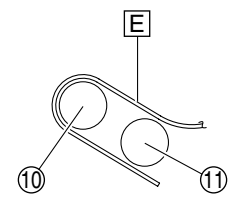

B-B

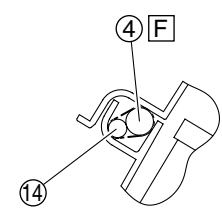

C-C

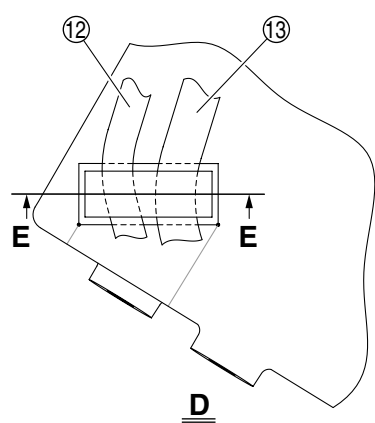
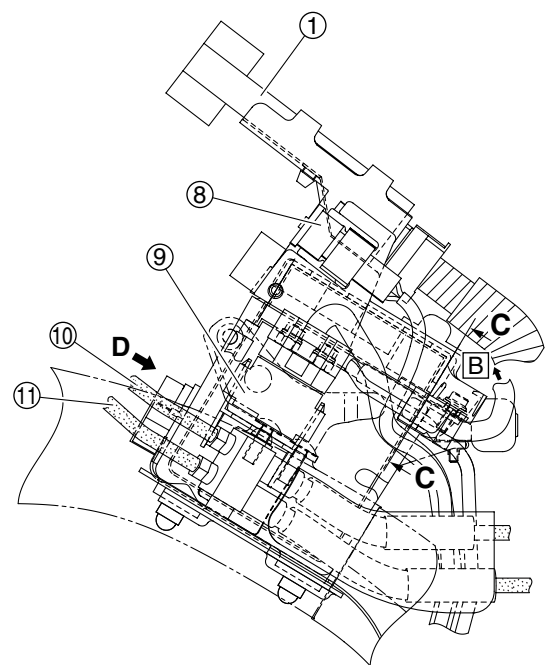

D

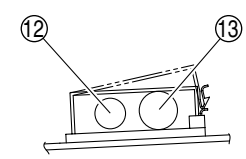

E-E

1. ECU (engine control unit)
2. Wire harness
3. Lean angle sensor
4. Positive battery lead (to positive battery terminal)
5. Main fuse lead
6. Starter relay lead
7. Battery
8. Main fuse
9. Starter relay
10. Brake hose (hydraulic unit to left front brake caliper)
11. Brake hose (front brake master cylinder to hydraulic unit)
12. Ignition coil sub-wire harness 1
13. Sub-wire harness
14. Positive battery lead (to wire harness)
 - A. To wire harness
 - B. To positive battery terminal
 - C. Route the leads that branch off from the wire harness through the slit in the battery box heat shield.
 - D. Route the main fuse lead and starter relay lead between the positive battery lead and the battery box.
 - E. Wrap the battery box heat shield around the brake hose (front brake master cylinder to hydraulic unit) and brake hose (hydraulic unit to left front brake caliper) as shown in the illustration.
 - F. Make sure that the positive battery lead (to positive battery terminal) is not pinched between the ECU tray and the battery box.

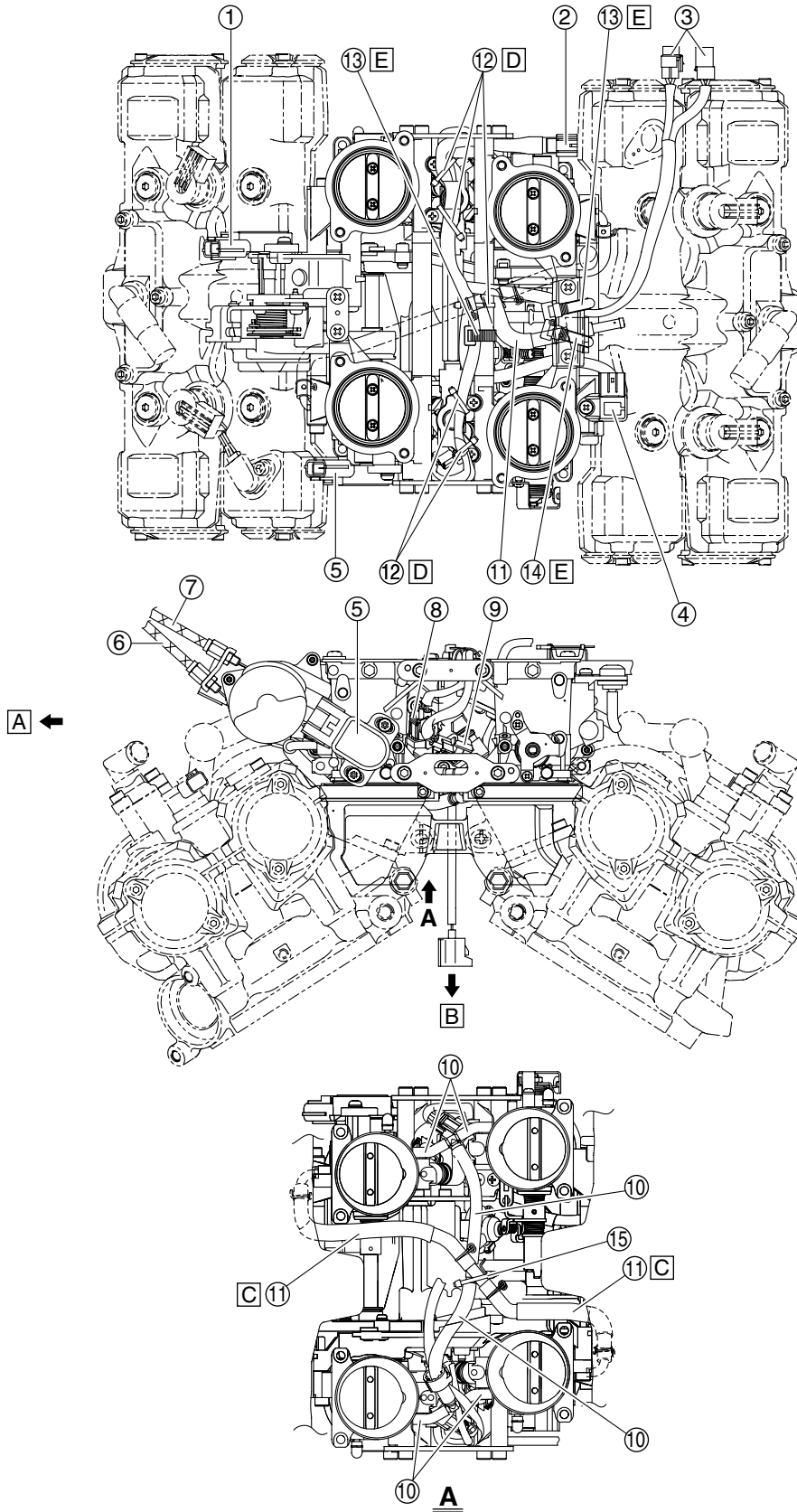

1. Accelerator position sensor
 2. Throttle servo motor coupler
 3. Sub-wire harness couplers
 4. Intake air pressure sensor
 5. Throttle position sensor
 6. Throttle cable (accelerator cable)
 7. Throttle cable (decelerator cable)
 8. Injector #2 coupler
 9. Injector #1 coupler
 10. Negative pressure hose
 11. Canister purge hose (California only)
 12. Plastic locking tie
 13. Plastic band
 14. Plastic band (California only)
 15. Plastic locking tie (California only)
- A. Forward
 - B. To coolant temperature sensor
 - C. Make sure that the canister purge hoses are not pinched between the cylinder head covers and the throttle valve shafts.
 - D. Position the plastic locking ties as shown in the illustration.
 - E. Position the plastic bands as shown in the illustration.

CABLE ROUTING

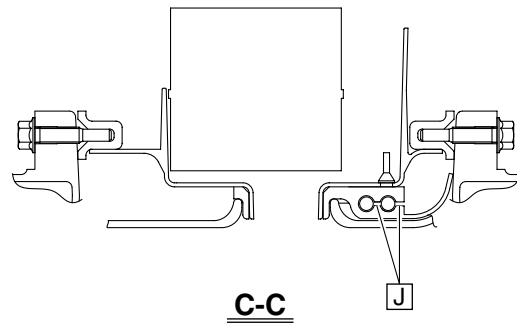
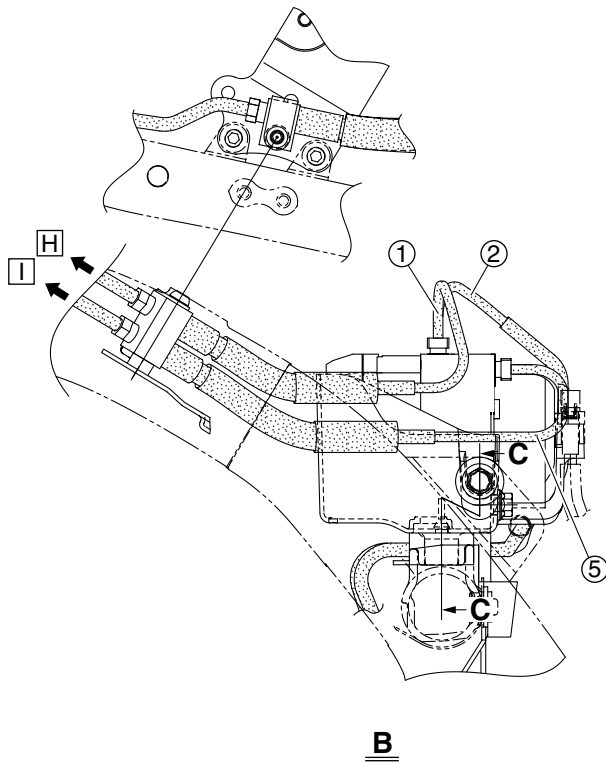
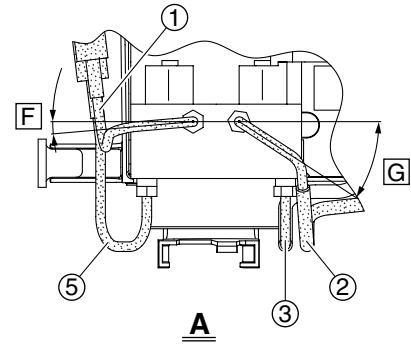
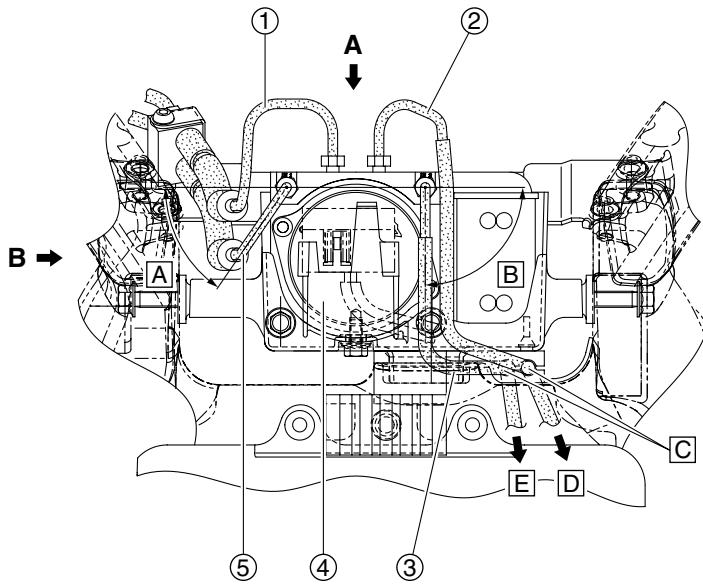

1. Brake hose (hydraulic unit to left front brake caliper)
2. Brake hose (hydraulic unit to rear brake caliper)
3. Brake hose (rear brake master cylinder to hydraulic unit)
4. Hydraulic unit assembly
5. Brake hose (front brake master cylinder to hydraulic unit)
 - A. 54–58°
 - B. 89–93°
- C. Fasten the brake hose (hydraulic unit to rear brake caliper) and brake hose (rear brake master cylinder to hydraulic unit) with the holder.
- D. To rear brake caliper
- E. To rear brake master cylinder
- F. 3–7°
- G. 30–34°
- H. To left front brake caliper
- I. To front brake master cylinder
- J. Be sure to position the brake hose (hydraulic unit to rear brake caliper) and brake hose (rear brake master cylinder to hydraulic unit) in the openings in the holder so that they are not pinched by the holder.

CABLE ROUTING

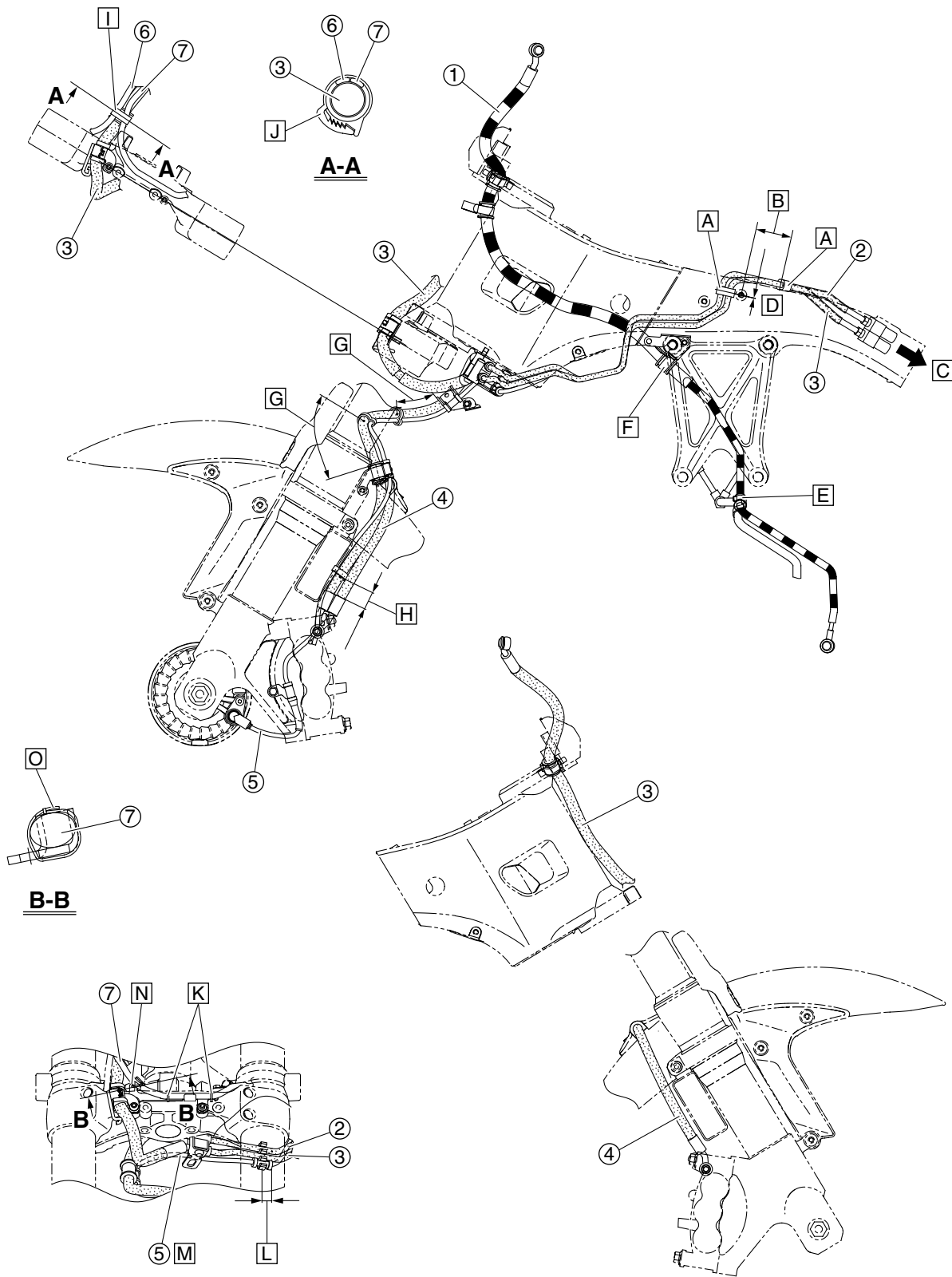

1. Clutch hose
2. Brake hose (hydraulic unit to left front brake caliper)
3. Brake hose (front brake master cylinder to hydraulic unit)
4. Brake hose (left front brake caliper to right front brake caliper)
5. Front wheel sensor lead
6. Front right turn signal/position light lead
7. Front left turn signal/position light lead
- A. Install the rubber damper so that the slits in the damper are toward the front frame.
- B. 45–51 mm (1.77–2.01 in)
- C. To hydraulic unit
- D. 0–3 mm (0–0.12 in)
- E. Fasten the clutch hose with the holder on the oil pipe 1.
- F. Insert the projection on the holder into the hole in the clutch hose holder bracket, and then fasten the clutch hose with the holder. Face the catch of the holder inward.
- G. 60–80 mm (2.36–3.15 in)
- H. 10–30 mm (0.39–1.18 in)
- I. Fasten the front right turn signal/position light lead, front left turn signal/position light lead, and grommet on the brake hose (front brake master cylinder to hydraulic unit) with the holder.
- J. Face the catch of the holder rearward.
- K. Fasten the front left turn signal/position light lead to the brake hose and front left turn signal/position light lead guide with plastic locking ties. Align the plastic locking ties with the cutouts in the guide. Cut off the excess end of each plastic locking tie to 2–5 mm (0.08–0.20 in). The end of each plastic locking tie may be pointing in any direction.
- L. 7–13 mm (0.28–0.51 in)
- M. Route the front wheel sensor lead between the brake hose guide and the front frame.
- N. Fasten the front left turn signal/position light lead with a plastic locking tie. Position the plastic locking tie under the bent portion of the brake hose and front left turn signal/position light lead guide.
- O. Point the end of the plastic locking tie to the left, and then cut off the excess end of the tie to 2–5 mm (0.08–0.20 in).

PERIODIC CHECKS AND ADJUSTMENTS

PERIODIC MAINTENANCE	3-1
INTRODUCTION	3-1
PERIODIC MAINTENANCE CHART FOR THE EMISSION CONTROL SYSTEM.....	3-1
GENERAL MAINTENANCE AND LUBRICATION CHART	3-1
ENGINE	3-4
ADJUSTING THE VALVE CLEARANCE	3-4
SYNCHRONIZING THE THROTTLE BODIES.....	3-7
ADJUSTING THE THROTTLE CABLE FREE PLAY	3-9
CHECKING THE SPARK PLUGS	3-9
CHECKING THE ENGINE OIL LEVEL.....	3-10
CHANGING THE ENGINE OIL	3-11
MEASURING THE ENGINE OIL PRESSURE	3-12
ADJUSTING THE CLUTCH LEVER.....	3-12
CHECKING THE CLUTCH FLUID LEVEL	3-13
BLEEDING THE HYDRAULIC CLUTCH SYSTEM	3-13
REPLACING THE AIR FILTER ELEMENT	3-14
CHECKING THE THROTTLE BODY JOINTS	3-15
CHECKING THE FUEL LINE	3-15
CHECKING THE CYLINDER HEAD BREATHER HOSE	3-15
CHECKING THE CRANKCASE BREATHER HOSE	3-16
CHECKING THE EXHAUST SYSTEM.....	3-16
CHECKING THE CANISTER (for California only).....	3-17
ADJUSTING THE EXUP CABLES	3-17
CHECKING THE COOLANT LEVEL.....	3-18
CHECKING THE COOLING SYSTEM	3-18
CHANGING THE COOLANT.....	3-19
CHECKING THE AIR INDUCTION SYSTEM.....	3-21

CHASSIS	3-22
ADJUSTING THE FRONT DISC BRAKE	3-22
CHECKING THE BRAKE FLUID LEVEL.....	3-22
CHECKING THE FRONT BRAKE PADS	3-23
CHECKING THE REAR BRAKE PADS	3-23
CHECKING THE BRAKE HOSES.....	3-23
CHECKING THE BRAKE LIGHT SWITCHES.....	3-23
ADJUSTING THE REAR BRAKE LIGHT SWITCH	3-23
BLEEDING THE HYDRAULIC BRAKE SYSTEM (ABS).....	3-24
ADJUSTING THE SHIFT PEDAL.....	3-25
CHECKING THE FINAL GEAR OIL LEVEL	3-25
CHANGING THE FINAL GEAR OIL	3-26
CHECKING AND ADJUSTING THE STEERING HEAD	3-26
CHECKING THE FRONT FORK	3-27
CHECKING THE REAR SUSPENSION	3-28
CHECKING THE SWINGARM PIVOT	3-28
ADJUSTING THE FRONT FORK LEGS	3-28
ADJUSTING THE REAR SHOCK ABSORBER ASSEMBLY	3-29
CHECKING THE TIRES.....	3-31
CHECKING THE WHEELS	3-32
CHECKING THE SIDESTAND.....	3-33
CHECKING AND LUBRICATING THE CABLES	3-33
LUBRICATING THE LEVERS	3-33
LUBRICATING THE PEDALS	3-33
LUBRICATING THE SIDESTAND.....	3-33
LUBRICATING THE REAR SUSPENSION.....	3-33
LUBRICATING THE SWINGARM PIVOT	3-33
LUBRICATING THE STEERING HEAD.....	3-33
CHECKING THE FASTENERS.....	3-33
ELECTRICAL SYSTEM	3-34
CHECKING AND CHARGING THE BATTERY	3-34
CHECKING THE FUSES	3-34
REPLACING THE HEADLIGHT BULB.....	3-34
ADJUSTING THE HEADLIGHT BEAM	3-34
CHECKING THE SWITCHES, LIGHTS AND SIGNALS	3-35
CHECKING THE SWITCHES	3-35



PERIODIC MAINTENANCE

EAS20450

PERIODIC MAINTENANCE

EAS20460

INTRODUCTION

This chapter includes all information necessary to perform recommended checks and adjustments. If followed, these preventive maintenance procedures will ensure more reliable vehicle operation, a longer service life and reduce the need for costly overhaul work. This information applies to vehicles already in service as well as to new vehicles that are being prepared for sale. All service technicians should be familiar with this entire chapter.

EAU17600

PERIODIC MAINTENANCE CHART FOR THE EMISSION CONTROL SYSTEM

No.	ITEM	ROUTINE	INITIAL	ODOMETER READINGS					
			600 mi (1000 km) or 1 month	4000 mi (7000 km) or 6 months	8000 mi (13000 km) or 12 months	12000 mi (19000 km) or 18 months	16000 mi (25000 km) or 24 months	20000 mi (31000 km) or 30 months	
1	* Fuel line	<ul style="list-style-type: none"> Check fuel hoses for cracks or damage. Replace if necessary. 		√	√	√	√	√	√
2	* Spark plugs	<ul style="list-style-type: none"> Check condition. Clean. Replace every 12000 mi (19000 km) or 18 months. 		√		Replace.			√
3	* Valve clearance	<ul style="list-style-type: none"> Check and adjust valve clearance when engine is cold. 	Every 26600 mi (42000 km)						
4	* Crankcase breather system	<ul style="list-style-type: none"> Check breather hose for cracks or damage. Replace if necessary. 		√	√	√	√	√	√
5	* Fuel injection	<ul style="list-style-type: none"> Adjust synchronization. 		√	√	√	√	√	√
6	* Exhaust system	<ul style="list-style-type: none"> Check for leakage. Tighten if necessary. Replace gasket(s) if necessary. 		√	√	√	√	√	√
7	* Evaporative emission control system (for California only)	<ul style="list-style-type: none"> Check control system for damage. Replace if necessary. 				√			√
8	* Air induction system	<ul style="list-style-type: none"> Check the air cut-off valve, reed valve, and hose for damage. Replace any damaged parts. 			√			√	

* Since these items require special tools, data and technical skills, have a Yamaha dealer perform the service.

EAU32185

GENERAL MAINTENANCE AND LUBRICATION CHART

No.	ITEM	ROUTINE	INITIAL	ODOMETER READINGS					
			600 mi (1000 km) or 1 month	4000 mi (7000 km) or 6 months	8000 mi (13000 km) or 12 months	12000 mi (19000 km) or 18 months	16000 mi (25000 km) or 24 months	20000 mi (31000 km) or 30 months	
1	* Air filter element	<ul style="list-style-type: none"> Replace. 	Every 24000 mi (37000 km)						
2	* Clutch	<ul style="list-style-type: none"> Check operation and fluid leakage. Correct if necessary. 	√	√	√	√	√	√	√
3	* Front brake	<ul style="list-style-type: none"> Check operation, fluid level, and for fluid leakage. Replace brake pads if necessary. 	√	√	√	√	√	√	√

PERIODIC MAINTENANCE

No.	ITEM	ROUTINE	INITIAL	ODOMETER READINGS					
			600 mi (1000 km) or 1 month	4000 mi (7000 km) or 6 months	8000 mi (13000 km) or 12 months	12000 mi (19000 km) or 18 months	16000 mi (25000 km) or 24 months	20000 mi (31000 km) or 30 months	
4	* Rear brake	<ul style="list-style-type: none"> Check operation, fluid level, and for fluid leakage. Replace brake pads if necessary. 	√	√	√	√	√	√	
5	* Brake hoses	<ul style="list-style-type: none"> Check for cracks or damage. Replace. 		√	√	√	√	√	
6	* Wheels	<ul style="list-style-type: none"> Check runout and for damage. Replace if necessary. 		√	√	√	√	√	
7	* Tires	<ul style="list-style-type: none"> Check tread depth and for damage. Replace if necessary. Check air pressure. Correct if necessary. 		√	√	√	√	√	
8	* Wheel bearings	<ul style="list-style-type: none"> Check bearings for smooth operation. Replace if necessary. 		√	√	√	√	√	
9	* Swingarm pivot bearings	<ul style="list-style-type: none"> Check bearing assemblies for looseness. Moderately repack with lithium-soap-based grease. 			√		Repack.		
10	* Steering bearings	<ul style="list-style-type: none"> Check bearing assemblies for looseness. Moderately repack with lithium-soap-based grease every 16000 mi (25000 km) or 24 months. 	√	√	√	√	Repack.	√	
11	* Chassis fasteners	<ul style="list-style-type: none"> Check all chassis fitting and fasteners. Correct if necessary. 		√	√	√	√	√	
12	Brake lever pivot shaft	<ul style="list-style-type: none"> Apply silicone grease lightly. 		√	√	√	√	√	
13	Brake pedal pivot shaft	<ul style="list-style-type: none"> Apply lithium-soap-based grease lightly. 		√	√	√	√	√	
14	Clutch lever pivot shaft	<ul style="list-style-type: none"> Apply silicone grease lightly. 		√	√	√	√	√	
15	Shift pedal pivot shaft	<ul style="list-style-type: none"> Apply lithium-soap-based grease lightly. 		√	√	√	√	√	
16	Sidestand pivot	<ul style="list-style-type: none"> Check operation. Apply lithium-soap-based grease lightly. 		√	√	√	√	√	
17	* Sidestand switch	<ul style="list-style-type: none"> Check operation and replace if necessary. 	√	√	√	√	√	√	
18	* Front fork	<ul style="list-style-type: none"> Check operation and for oil leakage. Replace if necessary. 		√	√	√	√	√	
19	* Shock absorber assembly	<ul style="list-style-type: none"> Check operation and for oil leakage. Replace if necessary. 		√	√	√	√	√	
20	* Rear suspension link pivots	<ul style="list-style-type: none"> Check operation. Correct if necessary. 			√		√		
21	Engine oil	<ul style="list-style-type: none"> Change (warm engine before draining). 	√	√	√	√	√	√	
22	* Engine oil filter cartridge	<ul style="list-style-type: none"> Replace. 	√		√		√		
23	* Cooling system	<ul style="list-style-type: none"> Check hoses for cracks or damage. Replace if necessary. 		√	√	√	√	√	
		<ul style="list-style-type: none"> Change with ethylene glycol anti-freeze coolant every 24 months. 					Change.		
24	* EXUP system	<ul style="list-style-type: none"> Check operation, cable free play and pulley position. 	√	Every 12000 mi (19000 km)					

PERIODIC MAINTENANCE

No.	ITEM	ROUTINE	INITIAL	ODOMETER READINGS				
			600 mi (1000 km) or 1 month	4000 mi (7000 km) or 6 months	8000 mi (13000 km) or 12 months	12000 mi (19000 km) or 18 months	16000 mi (25000 km) or 24 months	20000 mi (31000 km) or 30 months
25	Final gear oil	<ul style="list-style-type: none"> Check oil level and for oil leakage. Change at initial 600 mi (1000 km) or 1 month, and thereafter every 16000 mi (25000 km) or 24 months. 	Change.	√	√	√	Change.	√
26	* Front and rear brake switches	<ul style="list-style-type: none"> Check operation. 	√	√	√	√	√	√
27	* Control cables	<ul style="list-style-type: none"> Apply Yamaha chain and cable lube or engine oil thoroughly. 	√	√	√	√	√	√
28	* Throttle grip housing and cable	<ul style="list-style-type: none"> Check operation and free play. Adjust the throttle cable free play if necessary. Lubricate the throttle grip housing and cable. 		√	√	√	√	√
29	* Lights, signals and switches	<ul style="list-style-type: none"> Check operation. Adjust headlight beam. 	√	√	√	√	√	√

* Since these items require special tools, data and technical skills, have a Yamaha dealer perform the service.

TIP

From 24000 mi (37000 km) or 36 months, repeat the maintenance intervals starting from 8000 mi (13000 km) or 12 months.

EAU38440

TIP

- Air filter
 - This model's air filter is equipped with a disposable oil-coated paper element, which must not be cleaned with compressed air to avoid damaging it.
 - The air filter element needs to be replaced more frequently when riding in unusually wet or dusty areas.
- Hydraulic brake and clutch systems
 - After disassembling the brake or clutch master cylinders, caliper cylinders or clutch release cylinder, always change the fluid. Regularly check the brake and clutch fluid levels and fill the reservoirs as required.
 - Replace the oil seals on the inner parts of the brake or clutch master cylinders, caliper cylinders and clutch release cylinder every two years.
 - Replace the brake and clutch hoses every four years or if cracked or damaged.

EAS20472

ENGINE

EAS20530

ADJUSTING THE VALVE CLEARANCE

The following procedure applies to all of the valves.

TIP

- Valve clearance adjustment should be made on a cold engine, at room temperature.
- When the valve clearance is to be measured or adjusted, the piston must be at top dead center (TDC) on the compression stroke.

1. Remove:
 - Generator cover plate
Refer to "GENERATOR AND STARTER CLUTCH" on page 5-37.
 - Cylinder head covers
Refer to "CAMSHAFTS" on page 5-9.
2. Remove:
 - Timing mark accessing screw "1"
 - Crankshaft end cover "2"

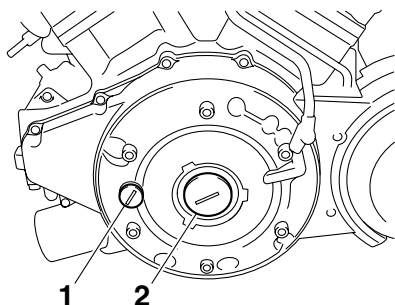

3. Measure:
 - Valve clearance
Out of specification → Adjust.

	Valve clearance (cold)
	Intake 0.10–0.17 mm (0.0039–0.0067 in)
	Exhaust 0.22–0.29 mm (0.0087–0.0114 in)

TIP

- If the valve clearance is incorrect, record the measured reading.
- Measure the valve clearance in the following sequence.

Valve clearance measuring sequence
Cylinder #1 → #3 → #2 → #4

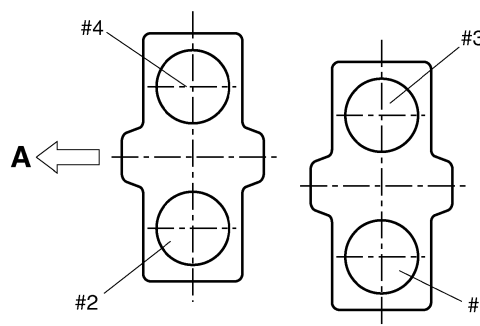

A. Front

Piston #1 TDC

- a. Position piston #1 at TDC by turning the crankshaft counterclockwise until the "T1" mark "a" on the generator rotor is aligned with the stationary pointer "b" on the generator cover.

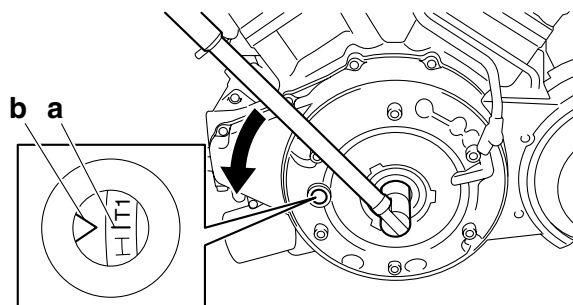

- b. Check that the punch mark "c", punch mark "d", and "1" mark "e" are aligned as shown.

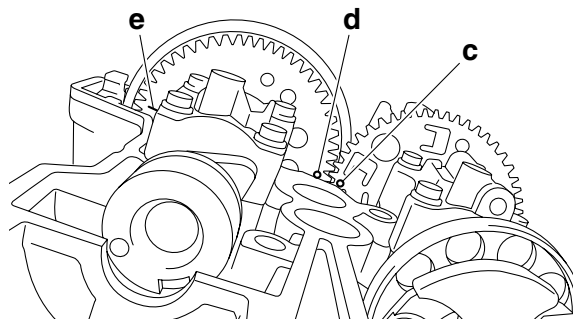

- c. Measure the valve clearance with a thickness gauge.

	Thickness gauge
	90890-03180
	Feeler gauge set
	YU-26900-9

Piston #3 TDC

- a. Position piston #1 at TDC.

- b. Turn the crankshaft almost 1/2 of a turn (167 degrees) counterclockwise until the "R" mark "a" on the generator rotor is aligned with the stationary pointer "b" on the generator cover.

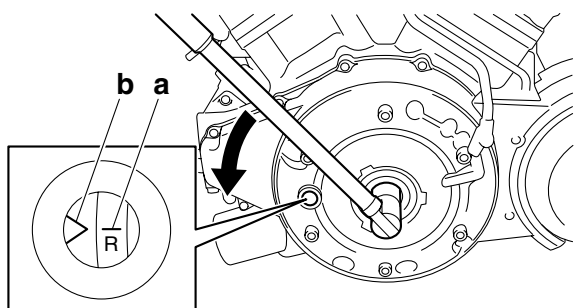

- c. Measure the valve clearance with a thickness gauge.

	Thickness gauge 90890-03180 Feeler gauge set YU-26900-9
--	--



Piston #2 TDC

- a. Position piston #2 at TDC by turning the crankshaft counterclockwise until the "T2" mark "a" on the generator rotor is aligned with the stationary pointer "b" on the generator cover.

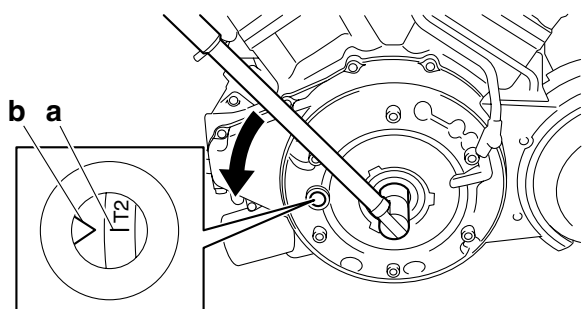

- b. Check that the punch mark "c", punch mark "d", and "I" mark "e" are aligned as shown.

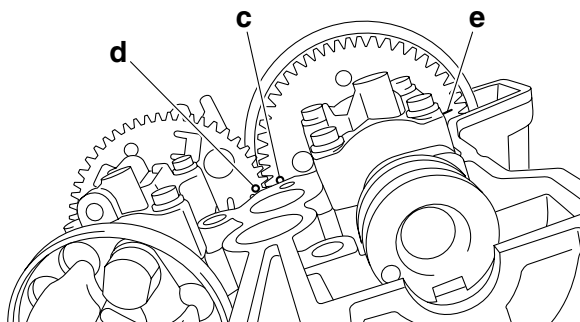

- c. Measure the valve clearance with a thickness gauge.

	Thickness gauge 90890-03180 Feeler gauge set YU-26900-9
--	--



Piston #4 TDC

- a. Position piston #2 at TDC.
b. Turn the crankshaft almost 2/3 of a turn (223 degrees) counterclockwise until the "F" mark "a" on the generator rotor is aligned with the stationary pointer "b" on the generator cover.

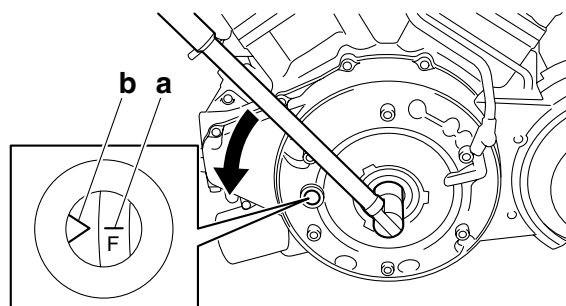

- c. Measure the valve clearance with a thickness gauge.

	Thickness gauge 90890-03180 Feeler gauge set YU-26900-9
--	--



4. Remove:
- Camshafts

TIP

- Refer to "CAMSHAFTS" on page 5-9.
- When removing the timing chain and camshafts, fasten the timing chain with a wire to retrieve it if it falls into the crankcase.

5. Adjust:
- Valve clearance



- a. Remove the valve lifter "1" and the valve pad "2" with a valve lapper "3".

	Valve lapper 90890-04101 Valve lapping tool YM-A8998
--	---

TIP

- Cover the timing chain opening with a rag to prevent the valve pad from falling into the crankcase.
- Make a note of the position of each valve lifter “1” and valve pad “2” so that they can be installed in the correct place.

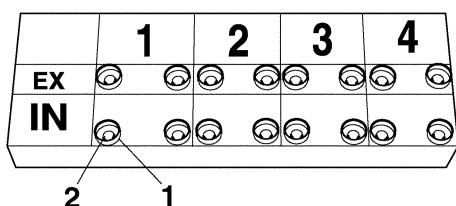
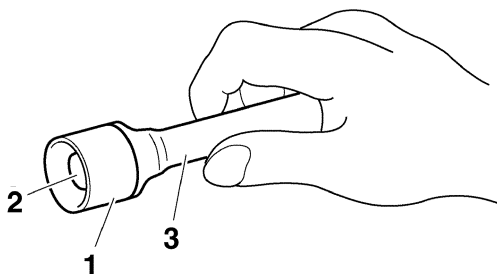

- b. Calculate the difference between the specified valve clearance and the measured valve clearance.

Example:

Specified valve clearance = 0.10–0.17 mm (0.0039–0.0067 in)

Measured valve clearance = 0.20 mm (0.0079 in)

$0.20 \text{ mm (0.0079 in)} - 0.17 \text{ mm (0.0067 in)} = 0.03 \text{ mm (0.001 in)}$

- c. Check the thickness of the current valve pad.

TIP

The thickness “a” of each valve pad is marked in hundredths of millimeters on the side that touches the valve lifter.

Example:

If the valve pad is marked “155”, the pad thickness is 1.55 mm (0.061 in).

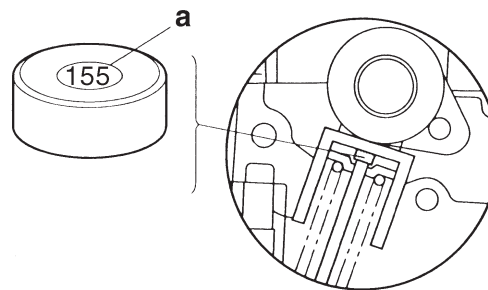

- d. Calculate the sum of the values obtained in steps (b) and (c) to determine the required valve pad thickness and the valve pad number.

Example:

$1.55 \text{ mm (0.061 in)} + 0.03 \text{ mm (0.001 in)} = 1.58 \text{ mm (0.062 in)}$

The valve pad number is 158.

- e. Round off the valve pad number according to the following table, and then select the suitable valve pad.

Last digit	Rounded value
0, 1, 2	0
3, 4, 5, 6	5
7, 8, 9	10

TIP

Refer to the following table for the available valve pads.

Valve pad range	No. 120–240
Valve pad thickness	1.20–2.40 mm (0.0472–0.0945 in)
Available valve pads	25 thicknesses in 0.05 mm (0.002 in) increments

Example:

Valve pad number = 158

Rounded value = 160

New valve pad number = 160

- f. Install the new valve pad “1” and the valve lifter “2”.

TIP

- Lubricate the valve lifter with engine oil.
- The valve lifter must turn smoothly when rotated by hand.
- Install the valve lifter and the valve pad in the correct place.

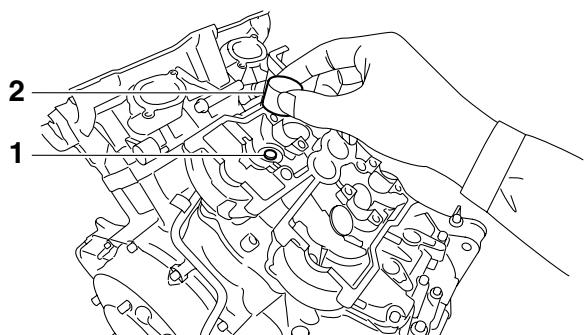

g. Install the exhaust and intake camshafts, timing chain and camshaft caps.



Camshaft cap bolt
10 Nm (1.0 m·kgf, 7.2 ft·lbf)

TIP

- Refer to “CAMSHAFTS” on page 5-9.
- Lubricate the camshaft lobes and camshaft journals.
- Turn the crankshaft clockwise several full turns to seat the parts.

h. Measure the valve clearance again.

i. If the valve clearance is still out of specification, repeat all of the valve clearance adjustment steps until the specified clearance is obtained.



6. Install:

- All removed parts

TIP

For installation, reverse the removal procedure.

EAS20571

SYNCHRONIZING THE THROTTLE BODIES

TIP

Before synchronizing the throttle bodies, check the following items:

- Valve clearance
- Spark plugs
- Air filter element
- Throttle body joints
- Fuel hoses
- Air induction system
- Exhaust system
- Canister purge hoses (for California only)
- Breather hoses

Checking the throttle body synchronization

1. Stand the vehicle on a level surface.

TIP

Place the vehicle on a suitable stand.

2. Remove:

- Caps “1”

A

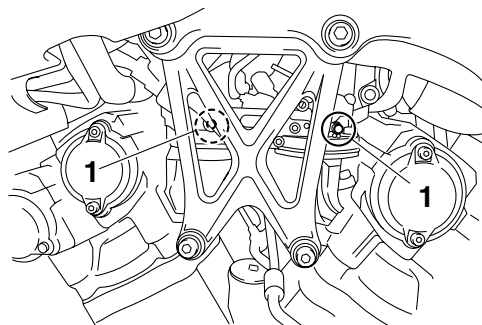

B

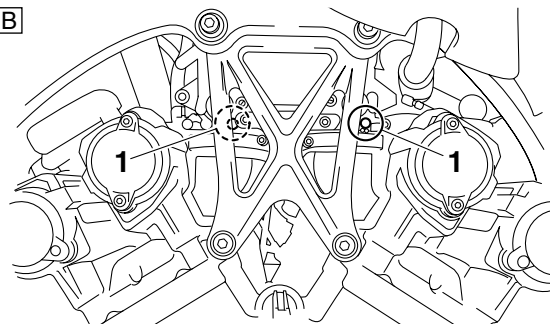

- A. Left side
- B. Right side

3. Install:

- Vacuum gauge “1”
- Digital tachometer



Vacuum gauge
90890-03094
Carburetor synchronizer
YU-44456

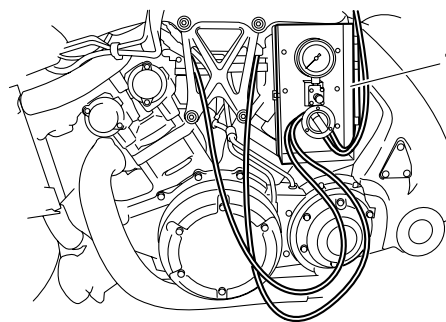

4. Check:

- Throttle body synchronization

EAS20630

ADJUSTING THE THROTTLE CABLE FREE PLAY

TIP

Prior to adjusting the throttle cable free play, the engine idling speed and throttle body synchronization should be adjusted properly.

1. Check:
 - Throttle cable free play "a"
Out of specification → Adjust.

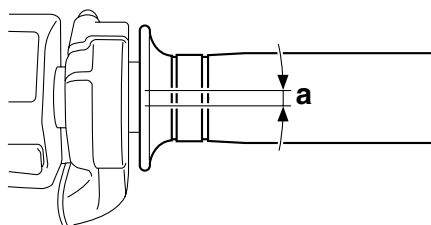

**Throttle cable free play
3.0–5.0 mm (0.12–0.20 in)**

2. Adjust:
 - Throttle cable free play

- a. Slide back the rubber cover "1".
- b. Loosen the locknut "2".
- c. Turn the adjusting nut "3" in direction "a" or "b" until the specified throttle cable free play is obtained.

Direction "a"
Throttle cable free play is increased.
Direction "b"
Throttle cable free play is decreased.

- d. Tighten the locknut.
- e. Slide the rubber cover to its original position.

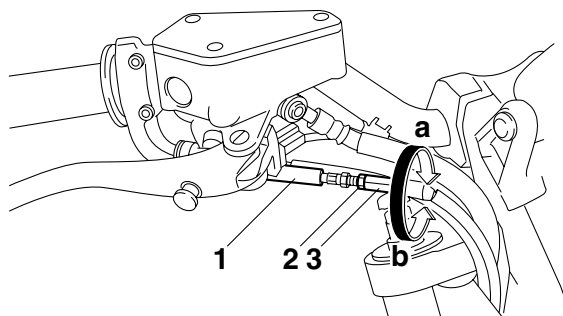

EAS20680

CHECKING THE SPARK PLUGS

The following procedure applies to all of the spark plugs.

1. Remove:
 - Battery box
Refer to "GENERAL CHASSIS" on page 4-1.
2. Disconnect:
 - Spark plug cap
3. Remove:
 - Spark plug

ECA13320

NOTICE

Before removing the spark plugs, blow away any dirt accumulated in the spark plug wells with compressed air to prevent it from falling into the cylinders.

4. Check:
 - Spark plug type
Incorrect → Change.



**Manufacturer/model
NGK/CR9EIA
Manufacturer/model
DENSO/IU27D**

5. Check:
 - Electrode "1"
Damage/wear → Replace the spark plug.
 - Insulator "2"
Abnormal color → Replace the spark plug.
Normal color is medium-to-light tan.
6. Clean:
 - Spark plug
(with a spark plug cleaner)

ECA2S31057

NOTICE

Do not use a wire brush to clean the spark plugs, as it will damage the iridium coating on the electrode.

7. Measure:
 - Spark plug gap "a"
(with a wire thickness gauge)
Out of specification → Replace.



**Spark plug gap
0.8–0.9 mm (0.031–0.035 in)**

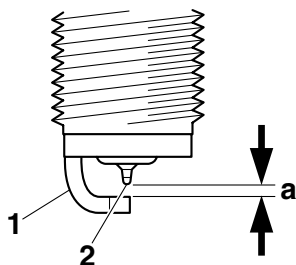

8. Install:

- Spark plug



Spark plug
13 Nm (1.3 m·kgf, 9.4 ft·lbf)

TIP

Before installing the spark plug, clean the spark plug and gasket surface.

9. Connect:

- Spark plug cap

10. Install:

- Battery box

Refer to “GENERAL CHASSIS” on page 4-1.

EAS28910

CHECKING THE ENGINE OIL LEVEL

1. Stand the vehicle on a level surface.

TIP

- Place the vehicle on a suitable stand.
- Make sure the vehicle is upright.

2. Start the engine, warm it up for several minutes, and then turn it off.

3. Check:

- Engine oil level

The engine oil level should be between the minimum level mark “a” and maximum level mark “b”.

Below the minimum level mark → Add the recommended engine oil to the proper level.

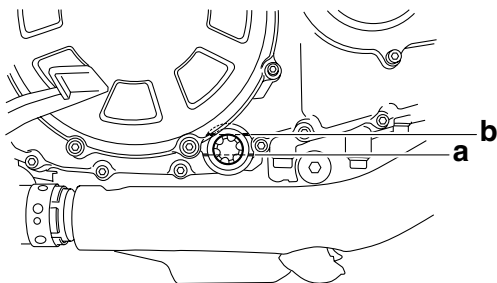

Type
YAMALUBE 4 10W-40 or 20W-50, SAE 10W-40 or SAE 20W-50
Recommended engine oil grade
API service SG type or higher,
JASO standard MA

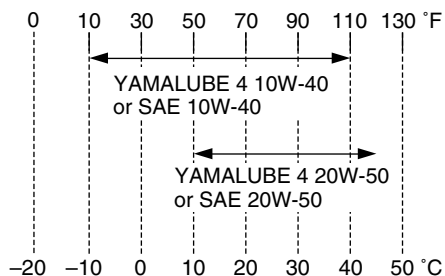

ECA2S31003

NOTICE

- Engine oil also lubricates the clutch and the wrong oil types or additives could cause clutch slippage. Therefore, do not add any chemical additives or use engine oils with a grade of CD “c” or higher and do not use oils labeled “ENERGY CONSERVING II” “d”.
- Do not allow foreign materials to enter the crankcase.

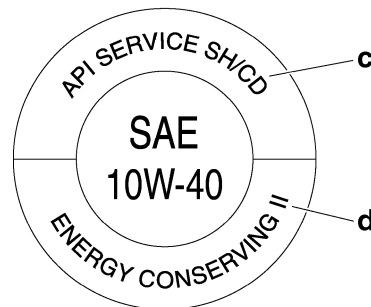

TIP

Before checking the engine oil level, wait a few minutes until the oil has settled.

4. Start the engine, warm it up for several minutes, and then turn it off.

5. Check the engine oil level again.

TIP

Before checking the engine oil level, wait a few minutes until the oil has settled.

EAS20780

CHANGING THE ENGINE OIL

1. Start the engine, warm it up for several minutes, and then turn it off.
2. Place a container under the engine oil drain bolt.
3. Remove:
 - Engine oil filler cap "1"
 - Engine oil drain bolt "2" (along with the gasket)

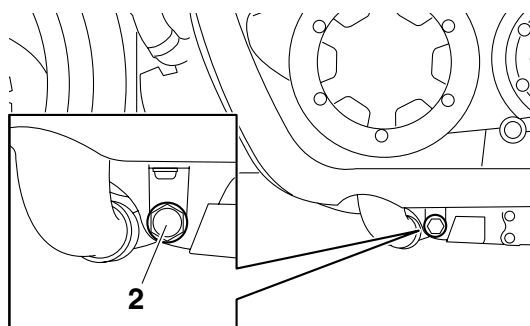
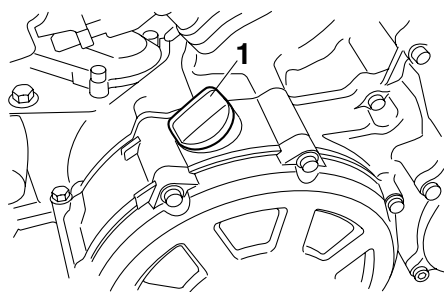

4. Drain:
 - Engine oil (completely from the crankcase)
5. If the oil filter cartridge is also to be replaced, perform the following procedure.

- a. Remove the oil filter cartridge "1" with an oil filter wrench "2".

	Oil filter wrench 90890-01426 YU-38411
--	---

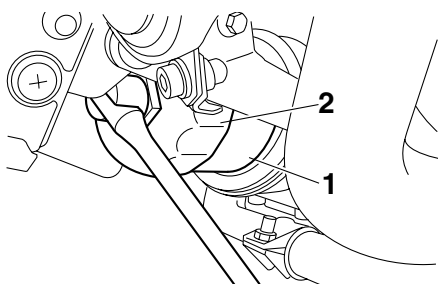

- b. Lubricate the O-ring "3" of the new oil filter cartridge with a thin coat of engine oil.

ECA13390

NOTICE

Make sure the O-ring "3" is positioned correctly in the groove of the oil filter cartridge.

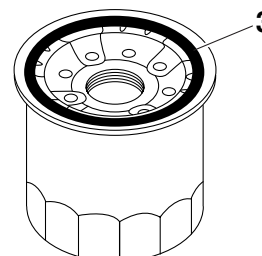

- c. Tighten the new oil filter cartridge to specification with an oil filter wrench.

	Oil filter cartridge 17 Nm (1.7 m·kgf, 12 ft·lbf)
--	--



6. Check:
 - Engine oil drain bolt gasket
Damage → Replace.
7. Install:
 - Engine oil drain bolt (along with the gasket)

	Engine oil drain bolt 43 Nm (4.3 m·kgf, 31 ft·lbf)
--	---

8. Fill:
 - Crankcase (with the specified amount of the recommended engine oil)

	Engine oil quantity Total amount 5.90 L (6.24 US qt, 5.19 Imp.qt) Without oil filter cartridge replacement 4.30 L (4.55 US qt, 3.78 Imp.qt) With oil filter cartridge replacement 4.70 L (4.97 US qt, 4.14 Imp.qt)
--	---

9. Install:
 - Engine oil filler cap
10. Start the engine, warm it up for several minutes, and then turn it off.
11. Check:
 - Engine (for engine oil leaks)

12. Check:

- Engine oil level
Refer to “CHECKING THE ENGINE OIL LEVEL” on page 3-10.

13. Check:

- Engine oil pressure
Refer to “MEASURING THE ENGINE OIL PRESSURE” on page 3-12.

EAS20820

MEASURING THE ENGINE OIL PRESSURE

1. Check:

- Engine oil level
Below the minimum level mark → Add the recommended engine oil to the proper level.

2. Start the engine, warm it up for several minutes, and then turn it off.

ECA13410

NOTICE

When the engine is cold, the engine oil will have a higher viscosity, causing the engine oil pressure to increase. Therefore, be sure to measure the engine oil pressure after warming up the engine.

3. Remove:

- Main gallery bolt

EWA12980

WARNING

The engine, muffler and engine oil are extremely hot.

4. Install:

- Oil pressure gauge “1”
- Oil pressure adapter “2”



**Oil pressure gauge set
90890-03120**
**Oil pressure adapter B
90890-03124**

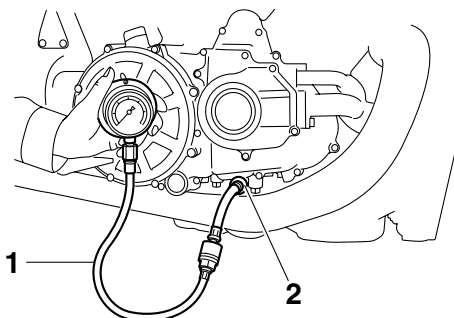

5. Measure:

- Engine oil pressure
(at the following conditions)



Oil pressure
50.0 kPa/1000 r/min (0.50 kgf/cm²/1000 r/min, 7.3 psi/1000 r/min)
Oil temperature
80.0–90.0 °C (176.00–194.00 °F)

Out of specification → Adjust.

Engine oil pressure	Possible causes
Below specification	<ul style="list-style-type: none"> • Faulty oil pump • Clogged oil filter • Leaking oil passage • Broken or damaged oil seal
Above specification	<ul style="list-style-type: none"> • Leaking oil passage • Faulty oil filter • Oil viscosity too high

6. Install:

- Main gallery bolt



Main gallery bolt
8 Nm (0.8 m·kgf, 5.8 ft·lbf)

EAS20860

ADJUSTING THE CLUTCH LEVER

1. Adjust:

- Clutch lever position
(distance “a” from the handlebar grip to the clutch lever)



- While pushing the clutch lever forward, turn the adjusting dial “1” until the clutch lever is in the desired position.

TIP

Be sure to align the setting on the adjusting dial with the arrow mark “2” on the clutch lever holder.

Position #1
Distance “a” is the largest.
Position #4
Distance “a” is the smallest.

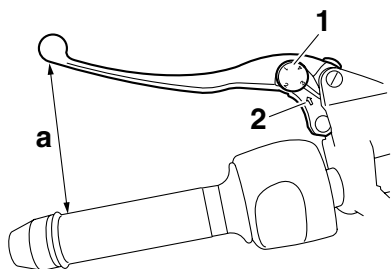

EAS20890

CHECKING THE CLUTCH FLUID LEVEL

1. Stand the vehicle on a level surface.

TIP

Place the vehicle on a suitable stand.

2. Check:

- Clutch fluid level

Below the minimum level mark “a” → Add the recommended clutch fluid to the proper level.



**Recommended fluid
DOT 4**

3. Remove:

- Clutch master cylinder reservoir cap
- Clutch master cylinder reservoir diaphragm holder
- Clutch master cylinder reservoir diaphragm

Refer to “CLUTCH” on page 5-48.

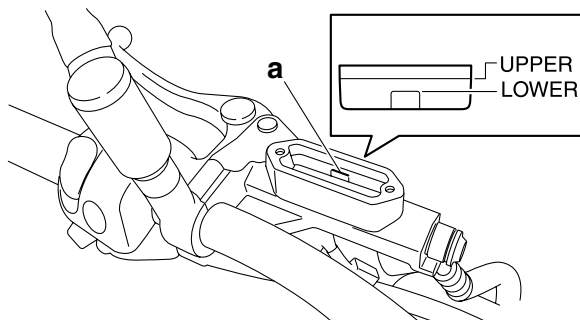

EWA13370

WARNING

- **Use only the designated clutch fluid. Other clutch fluids may cause the rubber seals to deteriorate, causing leakage and poor clutch performance.**
- **Refill with the same type of clutch fluid that is already in the system. Mixing clutch fluids may result in a harmful chemical reaction, leading to poor clutch performance.**

- **When refilling, be careful that water does not enter the clutch fluid reservoir. Water will significantly lower the boiling point of the clutch fluid and could cause vapor lock.**

ECA13420

NOTICE

Clutch fluid may damage painted surfaces or plastic parts. Therefore, always clean up any spilled clutch fluid immediately.

TIP

In order to ensure a correct reading of the clutch fluid level, make sure the top of the reservoir is horizontal.

4. Install:

- Clutch master cylinder reservoir diaphragm
- Clutch master cylinder reservoir diaphragm holder
- Clutch master cylinder reservoir cap

Refer to “CLUTCH” on page 5-48.

EAS20900

BLEEDING THE HYDRAULIC CLUTCH SYSTEM

EWA13000

WARNING

Bleed the hydraulic clutch system whenever:

- **the system was disassembled,**
- **a clutch hose was loosened or removed,**
- **the clutch fluid level is very low,**
- **clutch operation is faulty.**

TIP

- Be careful not to spill any clutch fluid or allow the clutch master cylinder reservoir to overflow.
- When bleeding the hydraulic clutch system, make sure there is always enough clutch fluid before applying the clutch lever. Ignoring this precaution could allow air to enter the hydraulic clutch system, considerably lengthening the bleeding procedure.
- If bleeding is difficult, it may be necessary to let the clutch fluid settle for a few hours. Repeat the bleeding procedure when the tiny bubbles in the hose have disappeared.

1. Remove:

- Clutch release cylinder cover “1”

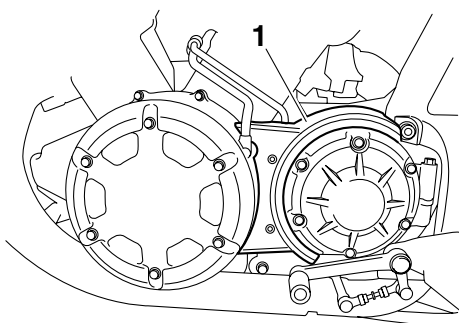

2. Bleed:
 • Hydraulic clutch system

- a. Add the recommended clutch fluid to the proper level.
 b. Install the clutch master cylinder reservoir diaphragm.
 c. Connect a clear plastic hose “1” tightly to the bleed screw “2”.

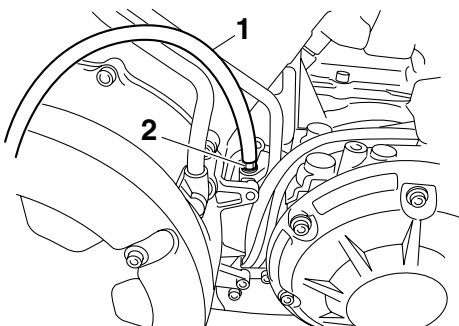

- d. Place the other end of the hose into a container.
 e. Slowly squeeze the clutch lever several times.
 f. Fully squeeze the clutch lever without releasing it.
 g. Loosen the bleed screw. This will release the tension and cause the clutch lever to contact the handlebar grip.
 h. Tighten the bleed screw and then release the clutch lever.
 i. Repeat steps (e) to (h) until all of the air bubbles have disappeared from the clutch fluid in the plastic hose.
 j. Tighten the bleed screw to specification.



Bleed screw
 5 Nm (0.5 m·kgf, 3.6 ft·lbf)

- k. Add the recommended clutch fluid to the proper level.
 Refer to “CHECKING THE CLUTCH FLUID LEVEL” on page 3-13.

EWA13010

WARNING

After bleeding the hydraulic clutch system, check the clutch operation.



EAS20961

REPLACING THE AIR FILTER ELEMENT

1. Remove:
 - Top cover
 - Intake duct assemblies
 - ECU tray
 Refer to “GENERAL CHASSIS” on page 4-1.
2. Remove:
 - Air filter case cover “1”

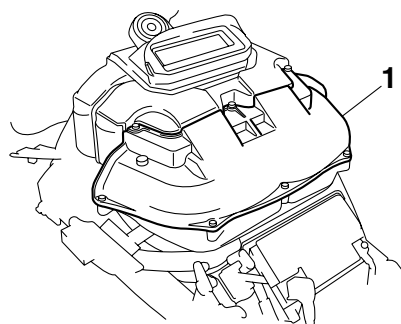

3. Remove:
 - Air filter element “1”

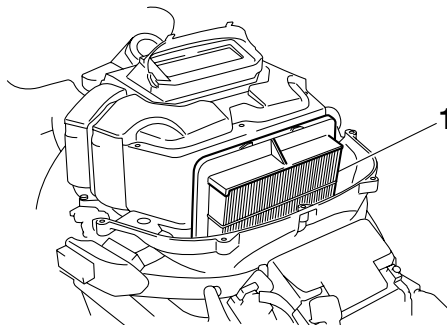

4. Check:
 - Air filter element
 Damage → Replace.

ECA2S31072

NOTICE

- Replace the air filter element every 37000 km (24000 mi) of operation.
- The air filter needs more frequent service if you are riding in unusually wet or dusty areas.

5. Install:
 - Air filter case cover

ECA2S31058

NOTICE

Never operate the engine without the air filter element installed. Unfiltered air will cause rapid wear of engine parts and may damage the engine. Operating the engine without the air filter element will also affect throttle body synchronization, leading to poor engine performance and possible overheating.

TIP

When installing the air filter element into the air filter case cover, make sure that the sealing surfaces are aligned to prevent any air leaks.

6. Install:
 - ECU tray
 - Intake duct assemblies
 - Top cover
 Refer to “GENERAL CHASSIS” on page 4-1.

EAS21010

CHECKING THE THROTTLE BODY JOINTS

1. Remove:
 - Top cover
 - Intake duct assemblies
Refer to “GENERAL CHASSIS” on page 4-1.
 - Lower air filter case
Refer to “AIR FILTER CASE” on page 7-6.
 - Throttle bodies
Refer to “THROTTLE BODIES” on page 7-11.
2. Check:
 - Throttle body joints “1”
Cracks/damage → Replace.

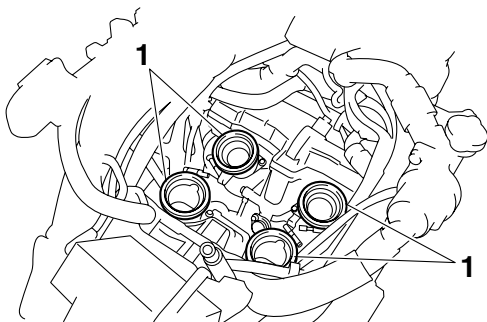

3. Install:
 - Throttle bodies
Refer to “THROTTLE BODIES” on page 7-11.
 - Air filter case
Refer to “AIR FILTER CASE” on page 7-6.
 - Intake duct assemblies
 - Top cover
Refer to “GENERAL CHASSIS” on page 4-1.

EAS21030

CHECKING THE FUEL LINE

1. Remove:
 - Rider seat
Refer to “GENERAL CHASSIS” on page 4-1.
2. Check:
 - Fuel hose “1”
 - Fuel tank breather hose “2”
Cracks/damage → Replace.
Loose connection → Connect properly.

ECA14940

NOTICE

Make sure the fuel tank breather hose is routed correctly.

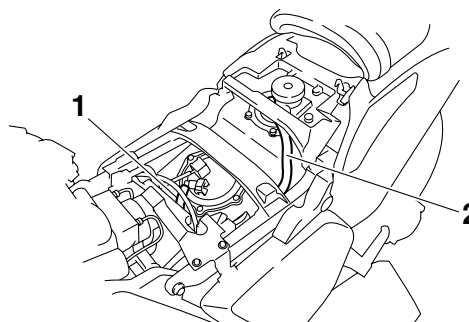

3. Install:
 - Rider seat
Refer to “GENERAL CHASSIS” on page 4-1.

EAS21050

CHECKING THE CYLINDER HEAD BREATHER HOSE

1. Check:
 - Cylinder head breather hose “1”
 - Cylinder head breather pipes
Cracks/damage → Replace.
Loose connection → Connect properly.

ECA14920

NOTICE

Make sure the cylinder head breather hose is routed correctly.

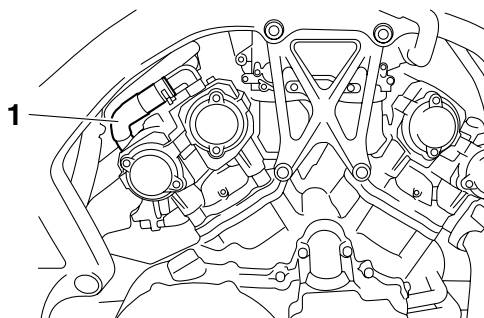

EAS21070

CHECKING THE CRANKCASE BREATHER HOSE

- Remove:
 - Top cover
 - Battery box

Refer to "GENERAL CHASSIS" on page 4-1.
- Pull back the battery box heat shield "1".
- Check:
 - Crankcase breather hose "2"
 - Crankcase breather pipe

Cracks/damage → Replace.
Loose connection → Connect properly.

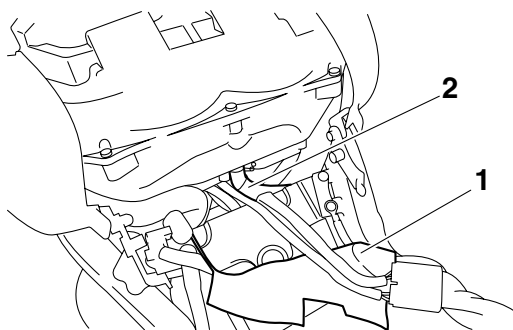

ECA13450

NOTICE

Make sure the crankcase breather hose is routed correctly.

- Return the battery box heat shield to its original position.
- Install:
 - Battery box
 - Top cover

Refer to "GENERAL CHASSIS" on page 4-1.

EAS21080

CHECKING THE EXHAUST SYSTEM

- Check:
 - Right front exhaust pipe "1"
 - Left front exhaust pipe "2"
 - Exhaust chamber "3"
 - Right muffler "4"
 - Left muffler "5"

Cracks/damage → Replace.
Gasket "6", "7", "8", "9"
Exhaust gas leaks → Replace.
- Remove:
 - Passenger seat
 - Rear fender

Refer to "GENERAL CHASSIS" on page 4-1.

 - Fuel tank

Refer to "FUEL TANK" on page 7-1.
- Check:
 - Rear exhaust pipe "10"

Cracks/damage → Replace.

- Gasket "11"
Exhaust gas leaks → Replace.

TIP

The rear exhaust pipe cannot be removed without removing the engine.

- Check:

Tightening torque

 - Front exhaust pipe nuts "12"
 - Left front exhaust pipe and right front exhaust pipe bolt "13"
 - Front exhaust pipe and exhaust chamber bolts "14"
 - Exhaust chamber and muffler bolts "15"
 - Rear exhaust pipe and exhaust chamber bolts "16"
 - Muffler bolts "17"
 - Exhaust chamber bolts "18"
 - Exhaust chamber bracket (front side) bolt "19"
 - Exhaust chamber bracket (left and right sides) bolts "20"
 - Rear exhaust pipe nuts "21"



Front exhaust pipe nut	20 Nm (2.0 m·kgf, 14 ft·lbf)
Left front exhaust pipe and right front exhaust pipe bolt	10 Nm (1.0 m·kgf, 7.2 ft·lbf)
Front exhaust pipe and exhaust chamber bolt	20 Nm (2.0 m·kgf, 14 ft·lbf)
Exhaust chamber and muffler bolt	20 Nm (2.0 m·kgf, 14 ft·lbf)
Rear exhaust pipe and exhaust chamber bolt	10 Nm (1.0 m·kgf, 7.2 ft·lbf)
Muffler bolt	20 Nm (2.0 m·kgf, 14 ft·lbf)
Exhaust chamber bolt	20 Nm (2.0 m·kgf, 14 ft·lbf)
Exhaust chamber bracket (front side) bolt	20 Nm (2.0 m·kgf, 14 ft·lbf)
Exhaust chamber bracket (left and right sides) bolt	7 Nm (0.7 m·kgf, 5.1 ft·lbf)
Rear exhaust pipe nut	20 Nm (2.0 m·kgf, 14 ft·lbf)

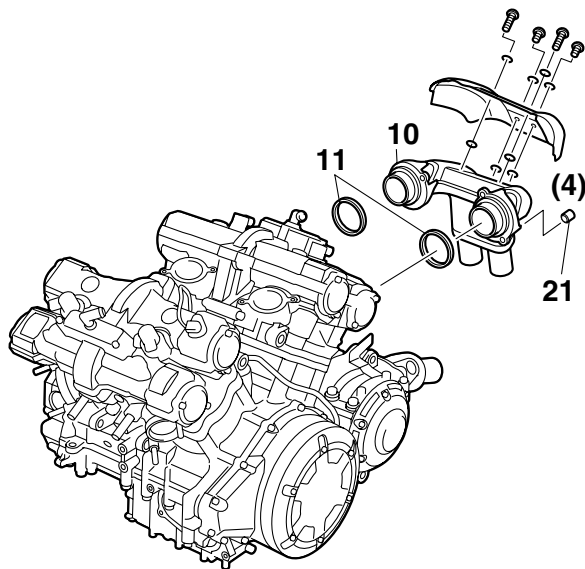
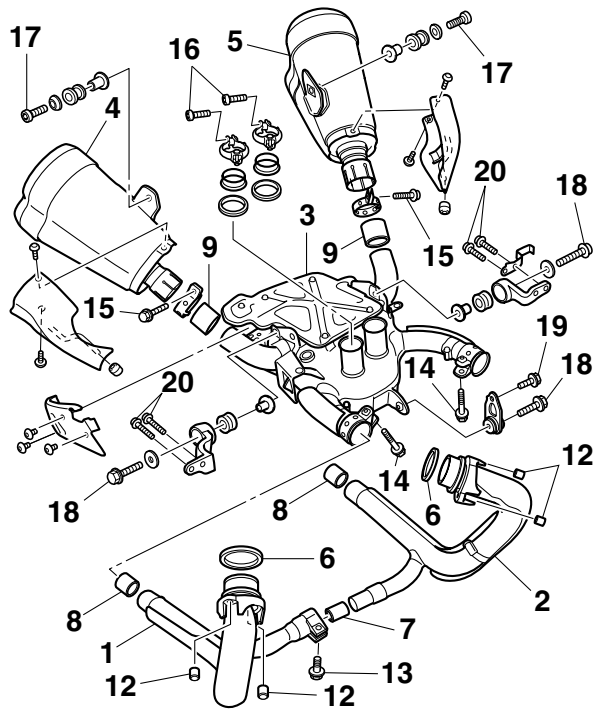

5. Install:
 - Fuel tank
Refer to "FUEL TANK" on page 7-1.
 - Rear fender
 - Passenger seat
Refer to "GENERAL CHASSIS" on page 4-1.

EAS21090

CHECKING THE CANISTER (for California only)

1. Remove:
 - Left side cover
Refer to "GENERAL CHASSIS" on page 4-1.
2. Check:
 - Canister "1"
 - Canister purge hose "2"
 - Fuel tank breather hose "3"
 - Canister breather hose "4"
 Cracks/damage → Replace.

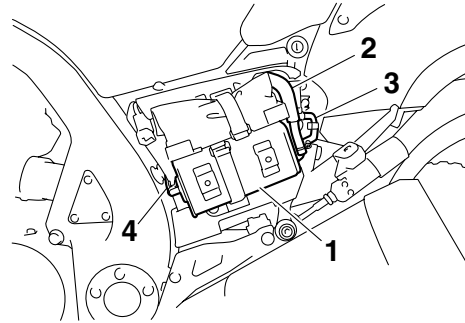

3. Install:
 - Left side cover
Refer to "GENERAL CHASSIS" on page 4-1.

EAS21100

ADJUSTING THE EXUP CABLES

1. Remove:
 - EXUP valve pulley cover "1"

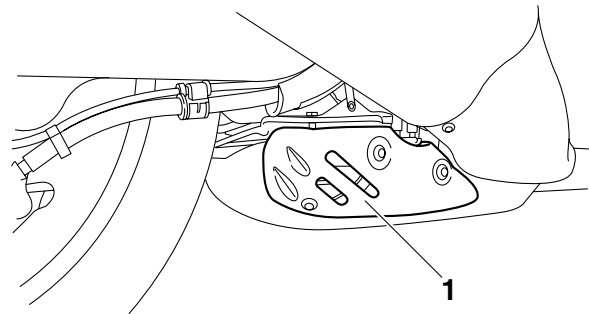

2. Check:
 - EXUP system operation



- a. Activate the diagnostic mode and select the diagnostic code No. D: 53.
Refer to "FUEL INJECTION SYSTEM" on page 8-33.
- b. Set the engine stop switch to "O".
- c. Turn the main switch to "ON".
- d. Check that the EXUP valve operates properly.

TIP

Check that the projection “a” on the EXUP valve pulley contacts the stopper “b” (fully open position). If the projection does not contact the stopper, adjust the EXUP cable.

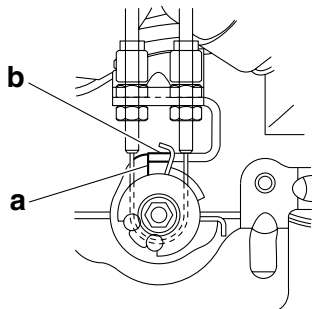

3. Adjust:

- EXUP cable

a. Loosen the locknuts “1” and “2”.

b. Turn the adjusting bolt “3” in or out until EXUP cable 1 is taut and the projection “a” on the EXUP valve pulley is lightly contacting the stopper “b” on the EXUP cable bracket.

c. Turn the adjusting bolt “4” in or out until the tension in EXUP cable 2 is the same as the tension in EXUP cable 1.

d. Tighten the locknuts “1” and “2” to specification.

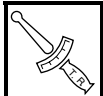

Locknut (EXUP cable adjusting bolt)
6 Nm (0.6 m·kgf, 4.3 ft·lbf)

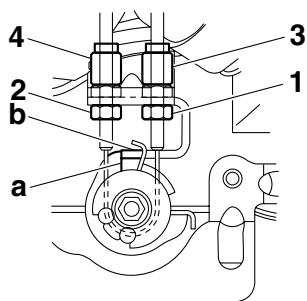

4. Install:

- EXUP valve pulley cover



EXUP valve pulley cover bolt
8 Nm (0.8 m·kgf, 5.8 ft·lbf)

EAS21110

CHECKING THE COOLANT LEVEL

1. Stand the vehicle on a level surface.

TIP

- Place the vehicle on a suitable stand.
- Make sure the vehicle is upright.

2. Check:

- Coolant level

The coolant level should be between the minimum level mark “a” and maximum level mark “b”.

Below the minimum level mark → Add the recommended coolant to the proper level.

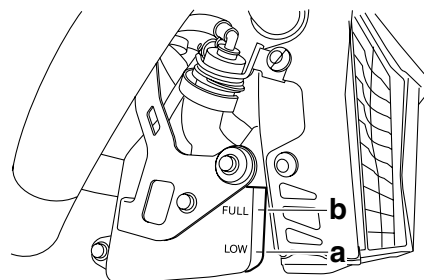

ECA13470

NOTICE

- **Adding water instead of coolant lowers the antifreeze content of the coolant. If water is used instead of coolant check, and if necessary, correct the antifreeze concentration of the coolant.**
- **Use only distilled water. However, if distilled water is not available, soft water may be used.**

3. Start the engine, warm it up for several minutes, and then turn it off.

4. Check:

- Coolant level

TIP

Before checking the coolant level, wait a few minutes until it settles.

EAS21120

CHECKING THE COOLING SYSTEM

1. Remove:

- Throttle bodies
Refer to “THROTTLE BODIES” on page 7-11.
- Front exhaust pipes
Refer to “ENGINE REMOVAL” on page 5-1.

2. Check:

- Radiator assembly “1”
- Upper radiator inlet hose “2”

- Upper radiator inlet pipe “3”
 - Thermostat outlet hose “4”
 - Lower radiator outlet hose “5”
 - Left lower radiator inlet hose
 - Right lower radiator inlet hose
 - Thermostat inlet hose 2 (front cylinder side) “6”
 - Thermostat inlet pipe 2 (front cylinder side) “7”
 - Thermostat inlet hose 1 (front cylinder side) “8”
 - Thermostat inlet pipe 1 (front cylinder side) “9”
 - Thermostat inlet pipe (rear cylinder side) “10”
 - Thermostat inlet hose (rear cylinder side) “11”
 - Thermostat outlet hose “12”
 - Oil cooler
 - Oil cooler outlet hose
 - Oil cooler inlet hose
 - Water pump outlet pipe
 - Water pump inlet pipe
- Cracks/damage → Replace.
Refer to “RADIATORS” on page 6-1, “OIL COOLER” on page 6-5, “THERMOSTAT” on page 6-7 and “WATER PUMP” on page 6-11.

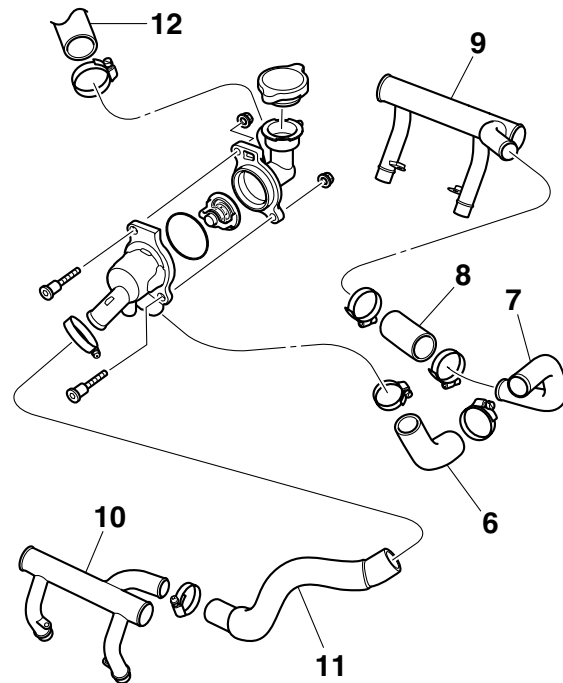
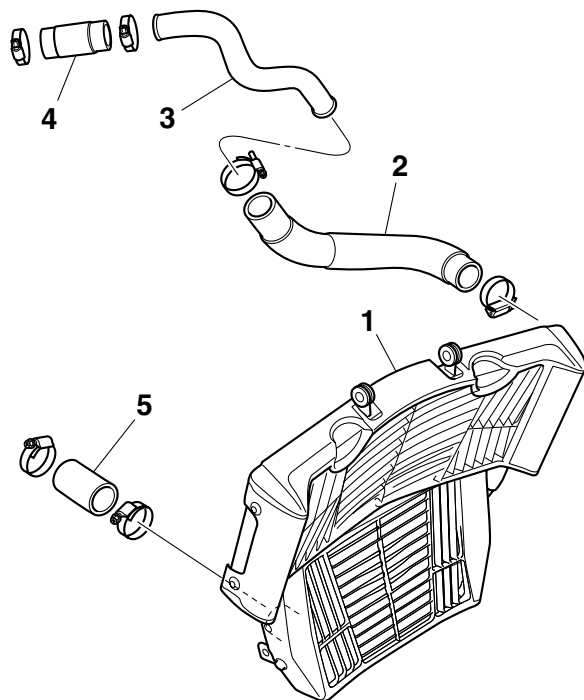

3. Install:
 - Front exhaust pipes
Refer to “ENGINE REMOVAL” on page 5-1.
 - Throttle bodies
Refer to “THROTTLE BODIES” on page 7-11.

EAS21130

CHANGING THE COOLANT

1. Remove:
 - Top cover
 - Right intake duct assembly
Refer to “GENERAL CHASSIS” on page 4-1.
2. Remove:
 - Radiator cap “1”

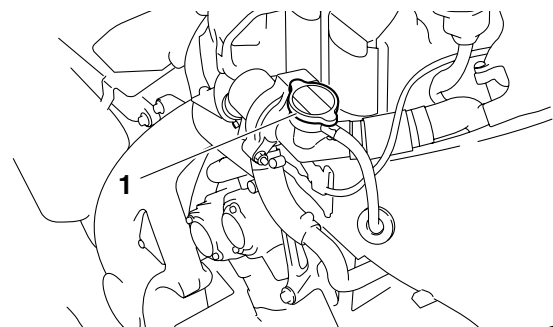

EWA13030



A hot radiator is under pressure. Therefore, do not remove the radiator cap when the engine is hot. Scalding hot fluid and steam may

be blown out, which could cause serious injury. When the engine has cooled, open the radiator cap as follows:

Place a thick rag or a towel over the radiator cap and slowly turn the radiator cap counterclockwise toward the detent to allow any residual pressure to escape. When the hissing sound has stopped, press down on the radiator cap and turn it counterclockwise to remove.

3. Remove:
 - Coolant drain screw "1" (along with the O-ring)

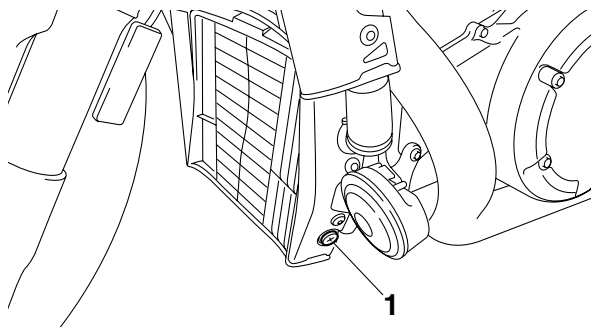

4. Drain:
 - Coolant (from the engine and radiator)
5. Remove:
 - Coolant reservoir cap guide "1"
 - Coolant reservoir "2"
 - Coolant reservoir cover "3"
 - Coolant reservoir cap "4"

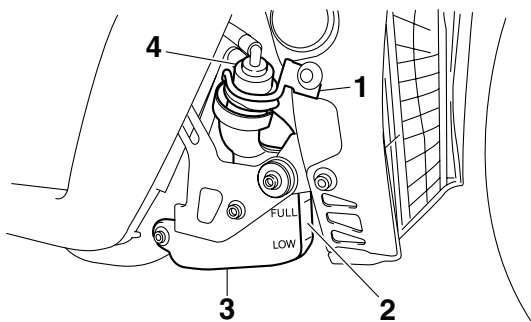

6. Drain:
 - Coolant (from the coolant reservoir)
7. Install:
 - Coolant reservoir cover
 - Coolant reservoir
8. Check:
 - Coolant drain screw O-ring
Damage → Replace.

9. Install:
 - Coolant drain screw (along with the O-ring)
10. Fill:
 - Cooling system (with the specified amount of the recommended coolant)



Recommended antifreeze
High-quality ethylene glycol antifreeze containing corrosion inhibitors for aluminum engines
Mixing ratio
 1:1 (antifreeze:water)
Radiator capacity (including all routes)
 3.75 L (3.96 US qt, 3.30 Imp.qt)
Coolant reservoir capacity (up to the maximum level mark)
 0.27 L (0.29 US qt, 0.24 Imp.qt)

Handling notes for coolant
 Coolant is potentially harmful and should be handled with special care.

EWA13040

WARNING

- If coolant splashes in your eyes, thoroughly wash them with water and consult a doctor.
- If coolant splashes on your clothes, quickly wash it away with water and then with soap and water.
- If coolant is swallowed, induce vomiting and get immediate medical attention.

ECA13480

NOTICE

- Adding water instead of coolant lowers the antifreeze content of the coolant. If water is used instead of coolant check, and if necessary, correct the antifreeze concentration of the coolant.
- Use only distilled water. However, if distilled water is not available, soft water may be used.
- If coolant comes into contact with painted surfaces, immediately wash them with water.
- Do not mix different types of antifreeze.

11. Install:
 - Radiator cap
12. Fill:
 - Coolant reservoir (with the recommended coolant to the maximum level mark "a")

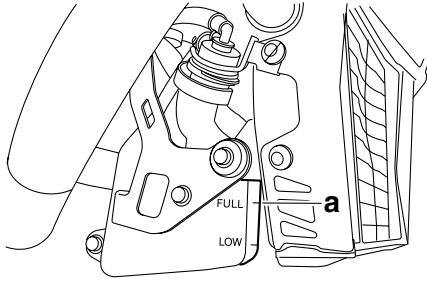

13. Install:

- Coolant reservoir cap
- Coolant reservoir cap guide

14. Start the engine, warm it up for several minutes, and then stop it.

15. Check:

- Coolant level
Refer to "CHECKING THE COOLANT LEVEL" on page 3-18.

TIP

Before checking the coolant level, wait a few minutes until the coolant has settled.

16. Install:

- Right intake duct assembly
- Top cover
Refer to "GENERAL CHASSIS" on page 4-1.

EAS2S31009

CHECKING THE AIR INDUCTION SYSTEM

Refer to "CHECKING THE AIR INDUCTION SYSTEM" on page 7-23

Direction "a"
 Brake light comes on sooner.
 Direction "b"
 Brake light comes on later.

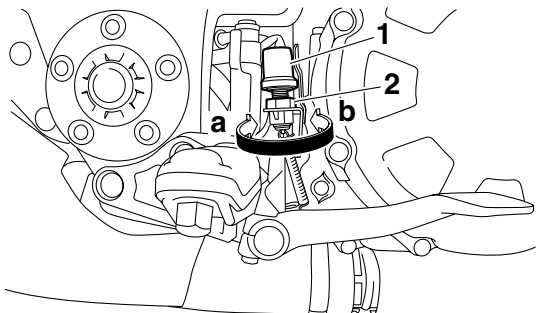

EAS2S31012

BLEEDING THE HYDRAULIC BRAKE SYSTEM (ABS)

EWA14000

WARNING

Always bleed the brake system when the brake related parts are removed.

ECA2S31004

NOTICE

- Bleed the brake system in the following order.
- 1st step: Front brake calipers
- 2nd step: Rear brake caliper

EWA2S31004

WARNING

Bleed the ABS whenever:

- the system is disassembled.
- a brake hose is loosened, disconnected or replaced.
- the brake fluid level is very low.
- brake operation is faulty.

TIP

- Be careful not to spill any brake fluid or allow the brake master cylinder reservoir or brake fluid reservoir to overflow.
- When bleeding the ABS, make sure that there is always enough brake fluid before applying the brake. Ignoring this precaution could allow air to enter the ABS, considerably lengthening the bleeding procedure.
- If bleeding is difficult, it may be necessary to let the brake fluid settle for a few hours.
- Repeat the bleeding procedure when the tiny bubbles in the hose have disappeared.

1. Bleed:

- ABS



- a. Fill the brake master cylinder reservoir or brake fluid reservoir to the proper level with the recommended brake fluid.
- b. Install the diaphragm (brake master cylinder reservoir or brake fluid reservoir).
- c. Connect a clear plastic hose "1" tightly to the bleed screw "2".

A

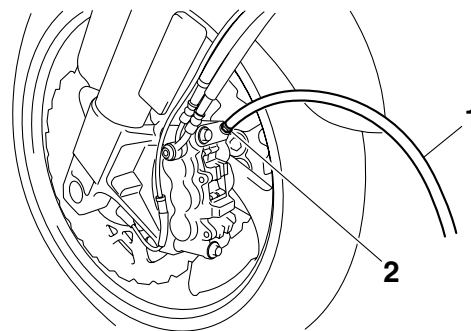

B

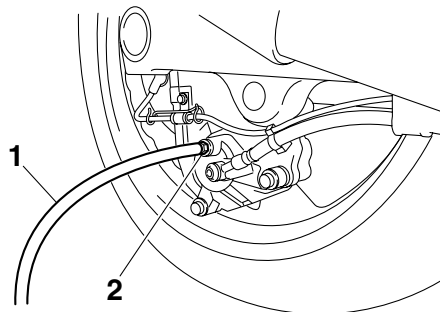

- A. Front brake caliper
 B. Rear brake caliper

- d. Place the other end of the hose into a container.
- e. Slowly apply the brake several times.
- f. Fully squeeze the brake lever or fully depress the brake pedal and hold it in position.
- g. Loosen the bleed screw.

TIP

Loosening the bleed screw will release the pressure and cause the brake lever to contact the throttle grip or the brake pedal to fully extend.

- h. Tighten the bleed screw and then release the brake lever or brake pedal.
- i. Repeat steps (e) to (h) until all of the air bubbles have disappeared from the brake fluid in the plastic hose.
- j. Check the operation of the hydraulic unit. Refer to "HYDRAULIC UNIT OPERATION TESTS" on page 4-59.

ECA2S31005

NOTICE

Make sure that the main switch is turned to “OFF” before checking the operation of the hydraulic unit.

- k. After operating the ABS, repeat steps (e) to (i), and then fill the brake master cylinder reservoir or brake fluid reservoir to the proper level with the recommended brake fluid.
- l. Tighten the bleed screw to specification.



Front brake caliper bleed screw
5 Nm (0.5 m·kgf, 3.6 ft·lbf)
Rear brake caliper bleed screw
6 Nm (0.6 m·kgf, 4.3 ft·lbf)

- m. Fill the brake fluid reservoir to the proper level with the recommended brake fluid. Refer to “CHECKING THE BRAKE FLUID LEVEL” on page 3-22.

EWA13110

WARNING

After bleeding the hydraulic brake system, check the brake operation.



EAS21380

ADJUSTING THE SHIFT PEDAL

TIP

The shift pedal position is determined by the installed shift rod length “a”.

- 1. Measure:
 - Installed shift rod length “a”
 Incorrect → Adjust.



Installed shift rod length
66.5–68.5 mm (2.62–2.70 in)

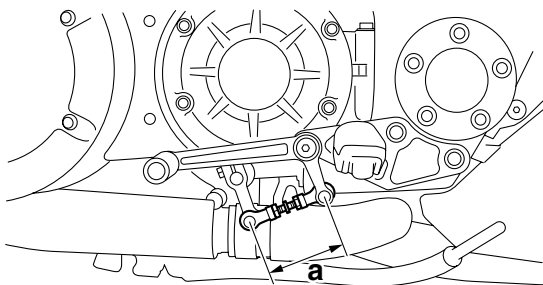

- 2. Adjust:
 - Installed shift rod length



- a. Loosen both locknuts “1”.

- b. Turn the adjusting bolt “2” in direction “a” or “b” until the specified installed shift rod length is obtained.

Direction “a”

Installed shift rod length increases.

Direction “b”

Installed shift rod length decreases.

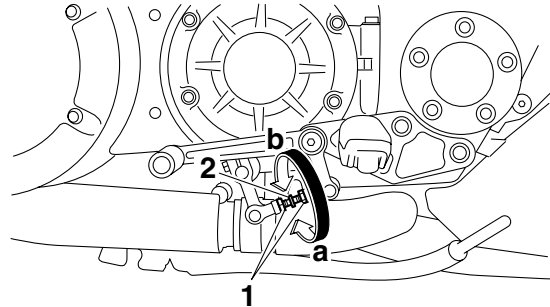

- c. Tighten both locknuts to specification.



Locknut

7 Nm (0.7 m·kgf, 5.1 ft·lbf)

- d. Make sure the installed shift rod length is within specification.



EAS21460

CHECKING THE FINAL GEAR OIL LEVEL

- 1. Stand the vehicle on a level surface.

TIP

- Place the vehicle on a suitable stand.
- Make sure the vehicle is upright.

- 2. Loosen:
 - Final gear oil check bolt “1”
- 3. Check:
 - Final gear oil level

A small amount of fluid should flow out of the check hole when the oil check bolt is loosened.

Does not flow out → Add the recommended final gear oil to the proper level.

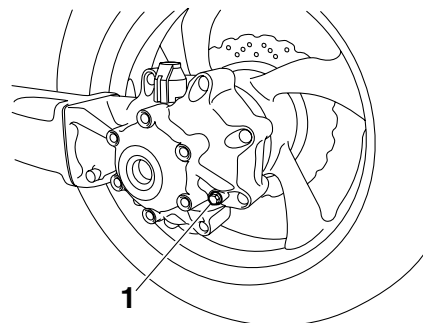

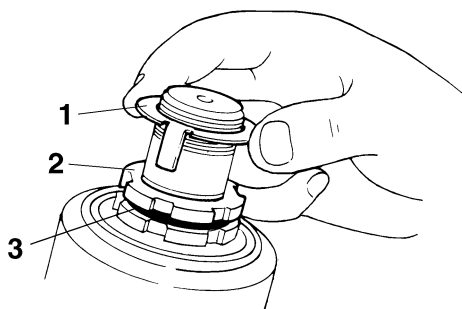

- b. Loosen the lower ring nut “4” and then tighten it to specification with a steering nut wrench “5”.

	Steering nut wrench 90890-01403 Exhaust flange nut wrench YU-A9472
---	---

	Lower ring nut (initial tightening torque) 52 Nm (5.2 m·kgf, 37 ft·lbf)
---	---

TIP
Set the torque wrench at a right angle to the steering nut wrench.

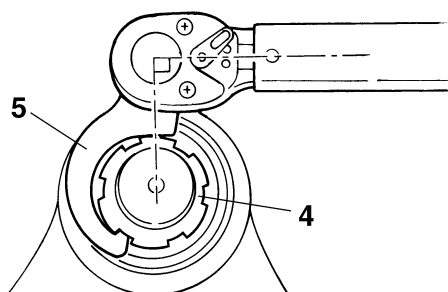

- c. Loosen the lower ring nut completely and then tighten it to specification with a steering nut wrench.

EWA13140

WARNING

Do not overtighten the lower ring nut.

	Lower ring nut (final tightening torque) 18 Nm (1.8 m·kgf, 13 ft·lbf)
---	---

- d. Check the steering head for looseness or binding by turning the front fork all the way in both directions. If any binding is felt, remove the lower bracket and check the upper and lower bearings.

- Refer to “STEERING HEAD” on page 4-78.
- Install the rubber washer “3”.
 - Install the upper ring nut “2”.
 - Finger tighten the upper ring nut, then align the slots of both ring nuts. If necessary, hold the lower ring nut and tighten the upper ring nut until their slots are aligned.
 - Install the lock washer “1”.

TIP
Make sure the lock washer tabs “a” sit correctly in the ring nut slots “b”.

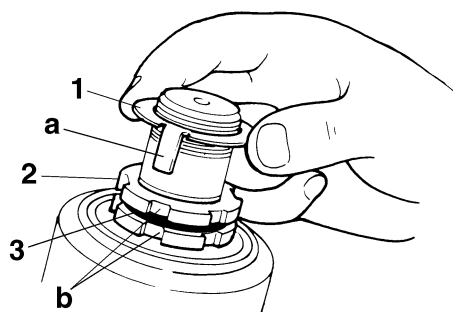

5. Install:
- Upper bracket
- Refer to “STEERING HEAD” on page 4-78.

EAS21530

CHECKING THE FRONT FORK

- Stand the vehicle on a level surface.

EWA13120

WARNING

Securely support the vehicle so that there is no danger of it falling over.

- Check:
 - Inner tube
Damage/scratches → Replace.
 - Oil seal
Oil leakage → Replace.
- Hold the vehicle upright and apply the front brake.
- Check:
 - Front fork operation
Push down hard on the handlebar several times and check if the front fork rebounds smoothly.
Rough movement → Repair.
Refer to “FRONT FORK” on page 4-68.

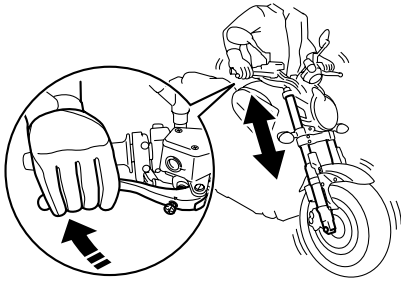

EAS2S31013

CHECKING THE REAR SUSPENSION

1. Stand the vehicle on a level surface.

EWA13120

WARNING

Securely support the vehicle so that there is no danger of it falling over.

2. Check:

- Rear shock absorber assembly
Gas leaks/oil leaks → Replace the rear shock absorber assembly.
Refer to “CHECKING THE REAR SHOCK ABSORBER ASSEMBLY AND GAS CYLINDER” on page 4-85.

3. Check:

- Rear shock absorber assembly operation
- Rear suspension link pivots
Push down seat on the vehicle several times and check if the rear shock absorber assembly rebounds smoothly.
Rough movement → Repair.
Refer to “REAR SHOCK ABSORBER ASSEMBLY” on page 4-83.

EAS2S31014

CHECKING THE SWINGARM PIVOT

1. Measure:

- Swingarm side play
- Swingarm vertical movement
Refer to “REMOVING THE SWINGARM” on page 4-89.

EAS21580

ADJUSTING THE FRONT FORK LEGS

The following procedure applies to both of the front fork legs.

EWA2S31005

WARNING

- Always adjust both front fork legs evenly.
Uneven adjustment can result in poor handling and loss of stability.
- Securely support the vehicle so that there is no danger of it falling over.

Spring preload

ECA13570

NOTICE

- Grooves are provided to indicate the adjustment position.
- Never go beyond the maximum or minimum adjustment positions.

- Adjust:
 - Spring preload

- Turn the adjusting bolt “1” in direction “a” or “b”.

Direction “a”

Spring preload is increased (suspension is harder).

Direction “b”

Spring preload is decreased (suspension is softer).



Spring preload adjusting positions

Minimum

5

Standard

4

Maximum

1

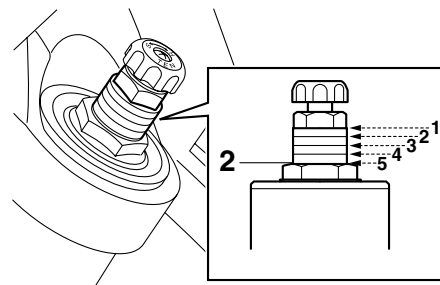
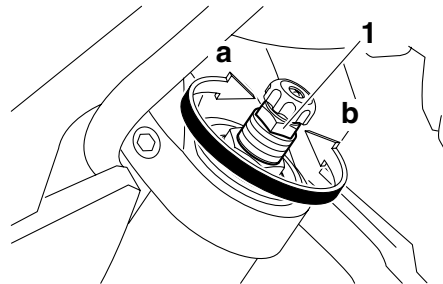

- Current setting

Rebound damping

ECA13590

NOTICE

Never go beyond the maximum or minimum adjustment positions.

- Adjust:
 - Rebound damping

- Turn the adjusting knob "1" in direction "a" or "b".

Direction "a"
Rebound damping is increased (suspension is harder).

Direction "b"
Rebound damping is decreased (suspension is softer).



Rebound damping adjusting positions

Minimum
17 click(s) out*

Standard
12 click(s) out*

Maximum
1 click(s) out*

* With the adjusting knob fully turned in

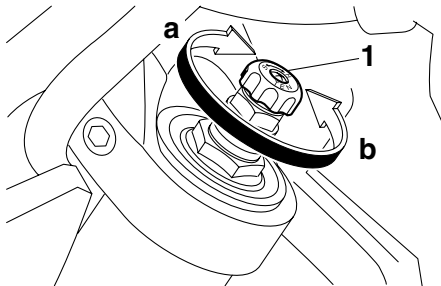

Direction "a"

Compression damping is increased (suspension is harder).

Direction "b"

Compression damping is decreased (suspension is softer).



Compression damping adjusting positions

Minimum
20 click(s) out*

Standard
12 click(s) out*

Maximum
1 click(s) out*

* With the adjusting screw fully turned in

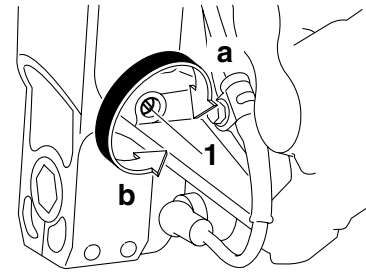

EAS21610

ADJUSTING THE REAR SHOCK ABSORBER ASSEMBLY

EWA13120

WARNING

Securely support the vehicle so that there is no danger of it falling over.

Compression damping

ECA13590

NOTICE

Never go beyond the maximum or minimum adjustment positions.

- Adjust:
 - Compression damping

- Turn the adjusting screw "1" in direction "a" or "b".

Spring preload

ECA13590

NOTICE

Never go beyond the maximum or minimum adjustment positions.

- Adjust:
 - Spring preload

- Turn the adjusting knob "1" in direction "a" or "b".

Direction “a”
Spring preload is increased (suspension is harder).

Direction “b”
Spring preload is decreased (suspension is softer).

Direction “a”
Rebound damping is increased (suspension is harder).

Direction “b”
Rebound damping is decreased (suspension is softer).

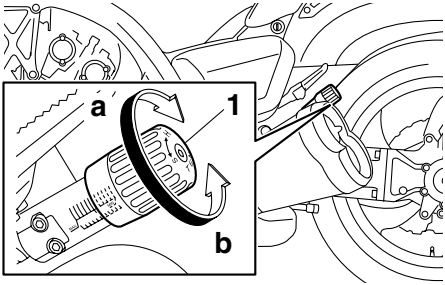

 **Rebound damping adjusting positions**

Minimum
20 click(s) out*

Standard
12 click(s) out*

Maximum
3 click(s) out*

* With the adjusting knob fully turned in

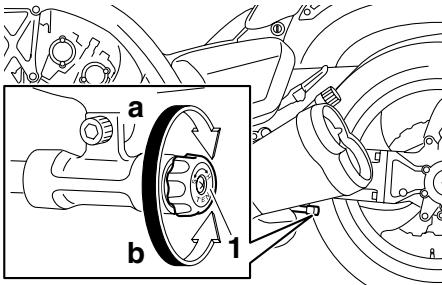
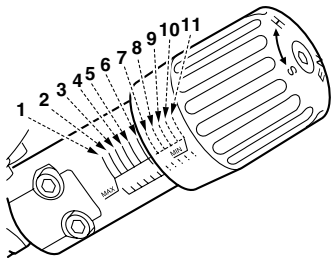

 **Spring preload adjusting positions**

Minimum
11

Standard
6

Maximum
1



Compression damping

ECA13590

NOTICE

Never go beyond the maximum or minimum adjustment positions.

1. Adjust:
 - Compression damping



- a. Turn the adjusting knob “1” in direction “a” or “b”.

Rebound damping

ECA13590

NOTICE

Never go beyond the maximum or minimum adjustment positions.

1. Adjust:
 - Rebound damping

- a. Turn the adjusting knob “1” in direction “a” or “b”.

Direction “a”
Compression damping is increased (suspension is harder).

Direction “b”
Compression damping is decreased (suspension is softer).



Compression damping adjusting positions

- Minimum
12 click(s) out*
- Standard
10 click(s) out*
- Maximum
1 click(s) out*

* With the adjusting knob fully turned in

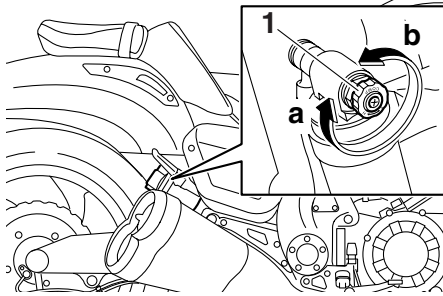

EAS21650

CHECKING THE TIRES

The following procedure applies to both of the tires.

1. Check:

- Tire pressure
Out of specification → Regulate.

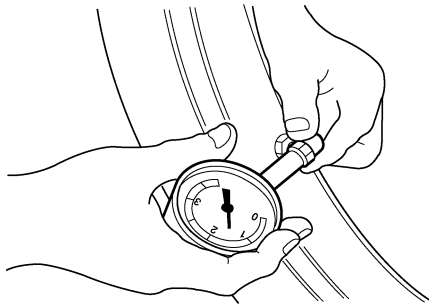

EWA13180

WARNING

- The tire pressure should only be checked and regulated when the tire temperature equals the ambient air temperature.
- The tire pressure and the suspension must be adjusted according to the total weight (including cargo, rider, passenger and accessories) and the anticipated riding speed.
- Operation of an overloaded vehicle could cause tire damage, an accident or an injury. **NEVER OVERLOAD THE VEHICLE.**



Tire air pressure (measured on cold tires)

- Loading condition
0–90 kg (0–198 lb)
- Front
250 kPa (2.50 kgf/cm², 36 psi)
- Rear
290 kPa (2.90 kgf/cm², 42 psi)
- Loading condition
90–190 kg (198–419 lb) (USA)
90–189 kg (198–417 lb) (California)
- Front
250 kPa (2.50 kgf/cm², 36 psi)
- Rear
290 kPa (2.90 kgf/cm², 42 psi)
- High-speed riding
- Front
290 kPa (2.90 kgf/cm², 42 psi)
- Rear
290 kPa (2.90 kgf/cm², 42 psi)
- Maximum load
190 kg (419 lb) (USA)
189 kg (417 lb) (California)

* Total weight of rider, passenger, cargo and accessories

EWA13190

WARNING

It is dangerous to ride with a worn-out tire. When the tire tread reaches the wear limit, replace the tire immediately.

2. Check:

- Tire surfaces
Damage/wear → Replace the tire.

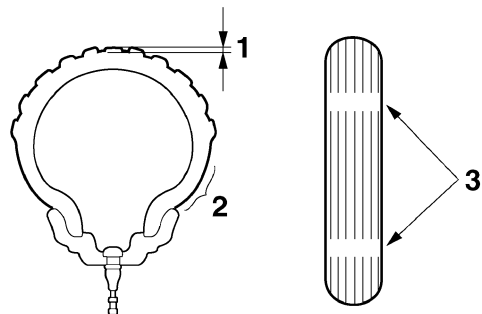

1. Tire tread depth
2. Side wall
3. Wear indicator



- Wear limit (front)
1.0 mm (0.04 in)
- Wear limit (rear)
1.0 mm (0.04 in)

EWA14080

WARNING

- Do not use a tubeless tire on a wheel designed only for tube tires to avoid tire failure and personal injury from sudden deflation.
- When using a tube tire, be sure to install the correct tube.
- Always replace a new tube tire and a new tube as a set.
- To avoid pinching the tube, make sure the wheel rim band and tube are centered in the wheel groove.
- Patching a punctured tube is not recommended. If it is absolutely necessary to do so, use great care and replace the tube as soon as possible with a good quality replacement.

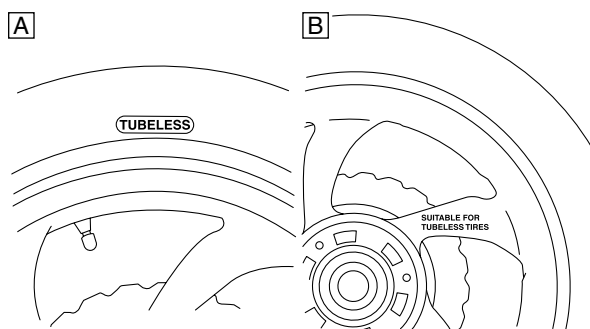

A. Tire
B. Wheel

Tube wheel	Tube tire only
Tubeless wheel	Tube or tubeless tire

EWA14090

WARNING

After extensive tests, the tires listed below have been approved by Yamaha Motor Co., Ltd. for this model. The front and rear tires should always be by the same manufacturer and of the same design. No guarantee concerning handling characteristics can be given if a tire combination other than one approved by Yamaha is used on this vehicle.



Front tire
Size
120/70R18M/C 59V
Manufacturer/model
BRIDGESTONE/BT028F



Rear tire
Size
200/50R18M/C 76V
Manufacturer/model
BRIDGESTONE/BT028R

EWA13210

WARNING

New tires have a relatively low grip on the road surface until they have been slightly worn. Therefore, approximately 100 km should be traveled at normal speed before any high-speed riding is done.

TIP

- For tires with a direction of rotation mark “1”:
- Install the tire with the mark pointing in the direction of wheel rotation.
- Align the mark “2” with the valve installation point.

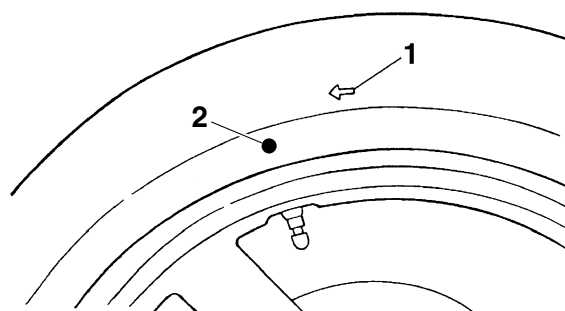

EAS21670

CHECKING THE WHEELS

The following procedure applies to both of the wheels.

1. Check:
 - Wheel
Damage/out-of-round → Replace.

EWA13260

WARNING

Never attempt to make any repairs to the wheel.

TIP

After a tire or wheel has been changed or replaced, always balance the wheel.

2. Measure:
 - Radial wheel runout
 - Lateral wheel runout

Refer to “CHECKING THE FRONT WHEEL” on page 4-14 and “CHECKING THE REAR WHEEL” on page 4-24.

3. Check:
 - Wheel bearings
Refer to “CHECKING THE FRONT WHEEL” on page 4-14 and “CHECKING THE REAR WHEEL” on page 4-24.

EAS2S31015

CHECKING THE SIDESTAND

1. Check:
 - Sidestand operation
Check that the sidestand moves smoothly.
Rough movement → Repair or replace.

EAS21690

CHECKING AND LUBRICATING THE CABLES

The following procedure applies to all of the inner and outer cables.

EWA13270



WARNING

Damaged outer cable may cause the cable to corrode and interfere with its movement. Replace damaged outer cable and inner cables as soon as possible.

1. Check:
 - Outer cable
Damage → Replace.
2. Check:
 - Cable operation
Rough movement → Lubricate.

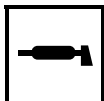

Recommended lubricant
Engine oil or a suitable cable lubricant

TIP

Hold the cable end upright and pour a few drops of lubricant into the cable sheath or use a suitable lubricating device.

EAS21700

LUBRICATING THE LEVERS

Lubricate the pivoting point and metal-to-metal moving parts of the levers.

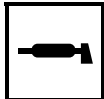

Recommended lubricant
Silicone grease

EAS21710

LUBRICATING THE PEDALS

Lubricate the pivoting point and metal-to-metal moving parts of the pedal.

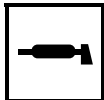

Recommended lubricant
Lithium-soap-based grease

EAS21720

LUBRICATING THE SIDESTAND

Lubricate the pivoting point and metal-to-metal moving parts of the sidestand.

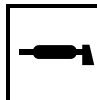

Recommended lubricant
Lithium-soap-based grease

EAS21740

LUBRICATING THE REAR SUSPENSION

Lubricate the pivoting point and metal-to-metal moving parts of the rear suspension.



Recommended lubricant
Lithium-soap-based grease

EAS2S31016

LUBRICATING THE SWINGARM PIVOT

1. Lubricate:
 - Bearings
 - Oil seals

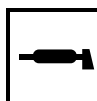

Recommended lubricant
Lithium-soap-based grease

Refer to “INSTALLING THE SWINGARM” on page 4-89.

EAS2S31017

LUBRICATING THE STEERING HEAD

1. Lubricate:
 - Upper bearing
 - Lower bearing
 - Bearing races
 - Bearing cover
 - Ring nut threads

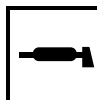

Recommended lubricant
Lithium-soap-based grease

EAS2S31018

CHECKING THE FASTENERS

1. Check:
 - Fasteners
Damage/pitting → Replace.
Refer to “GENERAL CHASSIS” on page 4-1.

EAS21750

ELECTRICAL SYSTEM

EAS21760

CHECKING AND CHARGING THE BATTERY

Refer to "ELECTRICAL COMPONENTS" on page 8-117.

EAS21770

CHECKING THE FUSES

Refer to "ELECTRICAL COMPONENTS" on page 8-117.

EAS21780

REPLACING THE HEADLIGHT BULB

1. Remove:
 - Headlight lens unit "1"

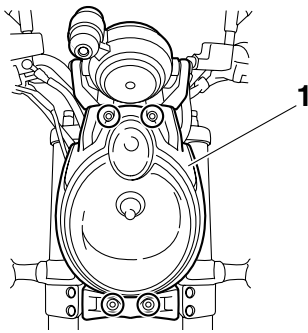

2. Disconnect:
 - Headlight coupler "1"
3. Remove:
 - Headlight bulb cover "2"

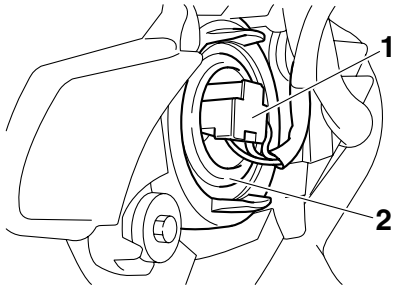

4. Detach:
 - Headlight bulb holder "1"
5. Remove:
 - Headlight bulb "2"

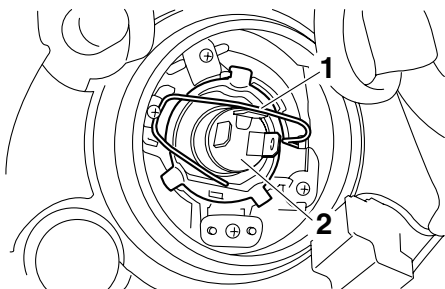

EWA13320

WARNING

Since the headlight bulb gets extremely hot, keep flammable products and your hands away from the bulb until it has cooled down.

6. Install:
 - Headlight bulb **New**
 - Secure the new headlight bulb with the headlight bulb holder.

ECA2S31075

NOTICE

Avoid touching the glass part of the headlight bulb to keep it free from oil; otherwise, the transparency of the glass, the life of the bulb and the luminous flux will be adversely affected. If the headlight bulb gets soiled, thoroughly clean it with a cloth moistened with alcohol or lacquer thinner.

7. Attach:
 - Headlight bulb holder
8. Install:
 - Headlight bulb cover
9. Connect:
 - Headlight coupler
10. Install:
 - Headlight lens unit

EAS21800

ADJUSTING THE HEADLIGHT BEAM

1. Adjust:
 - Headlight beam (vertically)
 - a. Turn the adjusting screw "1" in direction "a" or "b".

Direction "a"
Headlight beam is raised.
Direction "b"
Headlight beam is lowered.

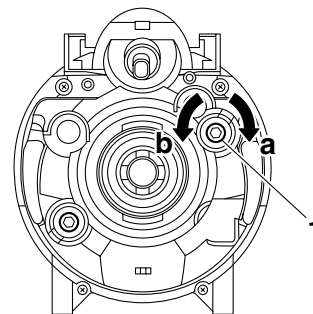

2. Adjust:
 - Headlight beam (horizontally)

CHASSIS

GENERAL CHASSIS	4-1
INSTALLING THE ABS TEST COUPLER.....	4-4
INSTALLING THE TOP COVER.....	4-8
INSTALLING THE BATTERY.....	4-10
FRONT WHEEL	4-12
REMOVING THE FRONT WHEEL.....	4-14
DISASSEMBLING THE FRONT WHEEL.....	4-14
CHECKING THE FRONT WHEEL.....	4-14
MAINTENANCE OF THE FRONT WHEEL SENSOR AND SENSOR ROTOR.....	4-15
ASSEMBLING THE FRONT WHEEL.....	4-16
ADJUSTING THE FRONT WHEEL STATIC BALANCE.....	4-17
INSTALLING THE FRONT WHEEL (FRONT BRAKE DISCS).....	4-18
REAR WHEEL	4-20
REMOVING THE REAR WHEEL (DISC).....	4-23
DISASSEMBLING THE REAR WHEEL.....	4-23
CHECKING THE REAR WHEEL.....	4-24
MAINTENANCE OF THE REAR WHEEL SENSOR AND SENSOR ROTOR.....	4-24
ASSEMBLING THE REAR WHEEL.....	4-24
ADJUSTING THE REAR WHEEL STATIC BALANCE.....	4-26
INSTALLING THE REAR WHEEL (REAR BRAKE DISC).....	4-26
FRONT BRAKE	4-29
INTRODUCTION.....	4-34
CHECKING THE FRONT BRAKE DISCS.....	4-34
REPLACING THE FRONT BRAKE PADS.....	4-35
REMOVING THE FRONT BRAKE CALIPERS.....	4-36
DISASSEMBLING THE FRONT BRAKE CALIPERS.....	4-36
CHECKING THE FRONT BRAKE CALIPERS.....	4-37
ASSEMBLING THE FRONT BRAKE CALIPERS.....	4-37
INSTALLING THE FRONT BRAKE CALIPERS.....	4-37
REMOVING THE FRONT BRAKE MASTER CYLINDER.....	4-38
CHECKING THE FRONT BRAKE MASTER CYLINDER.....	4-39
ASSEMBLING THE FRONT BRAKE MASTER CYLINDER.....	4-39
INSTALLING THE FRONT BRAKE MASTER CYLINDER.....	4-39

REAR BRAKE	4-41
INTRODUCTION	4-47
CHECKING THE REAR BRAKE DISC	4-47
REPLACING THE REAR BRAKE PADS	4-47
REMOVING THE REAR BRAKE CALIPER	4-48
DISASSEMBLING THE REAR BRAKE CALIPER	4-49
CHECKING THE REAR BRAKE CALIPER	4-49
ASSEMBLING THE REAR BRAKE CALIPER	4-49
INSTALLING THE REAR BRAKE CALIPER	4-50
REMOVING THE REAR BRAKE MASTER CYLINDER	4-52
CHECKING THE REAR BRAKE MASTER CYLINDER	4-52
ASSEMBLING THE REAR BRAKE MASTER CYLINDER	4-52
INSTALLING THE REAR BRAKE MASTER CYLINDER	4-52
ABS (ANTI-LOCK BRAKE SYSTEM)	4-55
ABS COMPONENTS CHART	4-55
REMOVING THE HYDRAULIC UNIT ASSEMBLY	4-57
CHECKING THE HYDRAULIC UNIT ASSEMBLY	4-57
CHECKING THE BRAKE HOSES	4-57
INSTALLING THE HYDRAULIC UNIT ASSEMBLY	4-58
HYDRAULIC UNIT OPERATION TESTS	4-59
TRIAL RUN	4-62
HANDLEBAR	4-63
REMOVING THE HANDLEBAR	4-65
CHECKING THE HANDLEBAR	4-65
INSTALLING THE HANDLEBAR	4-65
FRONT FORK	4-68
REMOVING THE FRONT FORK LEGS	4-72
DISASSEMBLING THE FRONT FORK LEGS	4-72
CHECKING THE FRONT FORK LEGS	4-73
ASSEMBLING THE FRONT FORK LEGS	4-73
INSTALLING THE FRONT FORK LEGS	4-77
STEERING HEAD	4-78
REMOVING THE LOWER BRACKET	4-81
CHECKING THE STEERING HEAD	4-81
INSTALLING THE STEERING HEAD	4-81
REAR SHOCK ABSORBER ASSEMBLY	4-83
HANDLING THE REAR SHOCK ABSORBER AND GAS CYLINDER	4-85
DISPOSING OF A REAR SHOCK ABSORBER	4-85
REMOVING THE REAR SHOCK ABSORBER ASSEMBLY	4-85
CHECKING THE REAR SHOCK ABSORBER ASSEMBLY AND GAS CYLINDER	4-85
CHECKING THE CONNECTING ARM AND RELAY ARM	4-85
INSTALLING THE REAR SHOCK ABSORBER ASSEMBLY	4-86

SWINGARM	4-88
REMOVING THE SWINGARM.....	4-89
CHECKING THE SWINGARM	4-89
INSTALLING THE SWINGARM	4-89
SHAFT DRIVE	4-91
TROUBLESHOOTING	4-95
CHECKING THE FINAL GEAR OIL FOR CONTAMINATION AND CHECKING THE SHAFT DRIVE FOR LEAKS	4-96
MEASURING THE FINAL GEAR BACKLASH	4-96
ADJUSTING THE FINAL GEAR BACKLASH	4-97
DISASSEMBLING THE FINAL DRIVE ASSEMBLY	4-98
REMOVING AND INSTALLING THE BEARING	4-99
ASSEMBLING THE FINAL DRIVE ASSEMBLY	4-99
ALIGNING THE FINAL DRIVE PINION GEAR AND RING GEAR.....	4-100
CHECKING THE DRIVE SHAFT.....	4-103
INSTALLING THE FINAL DRIVE ASSEMBLY	4-103

EAS21830

GENERAL CHASSIS

Removing the seats, side covers, and rear fender

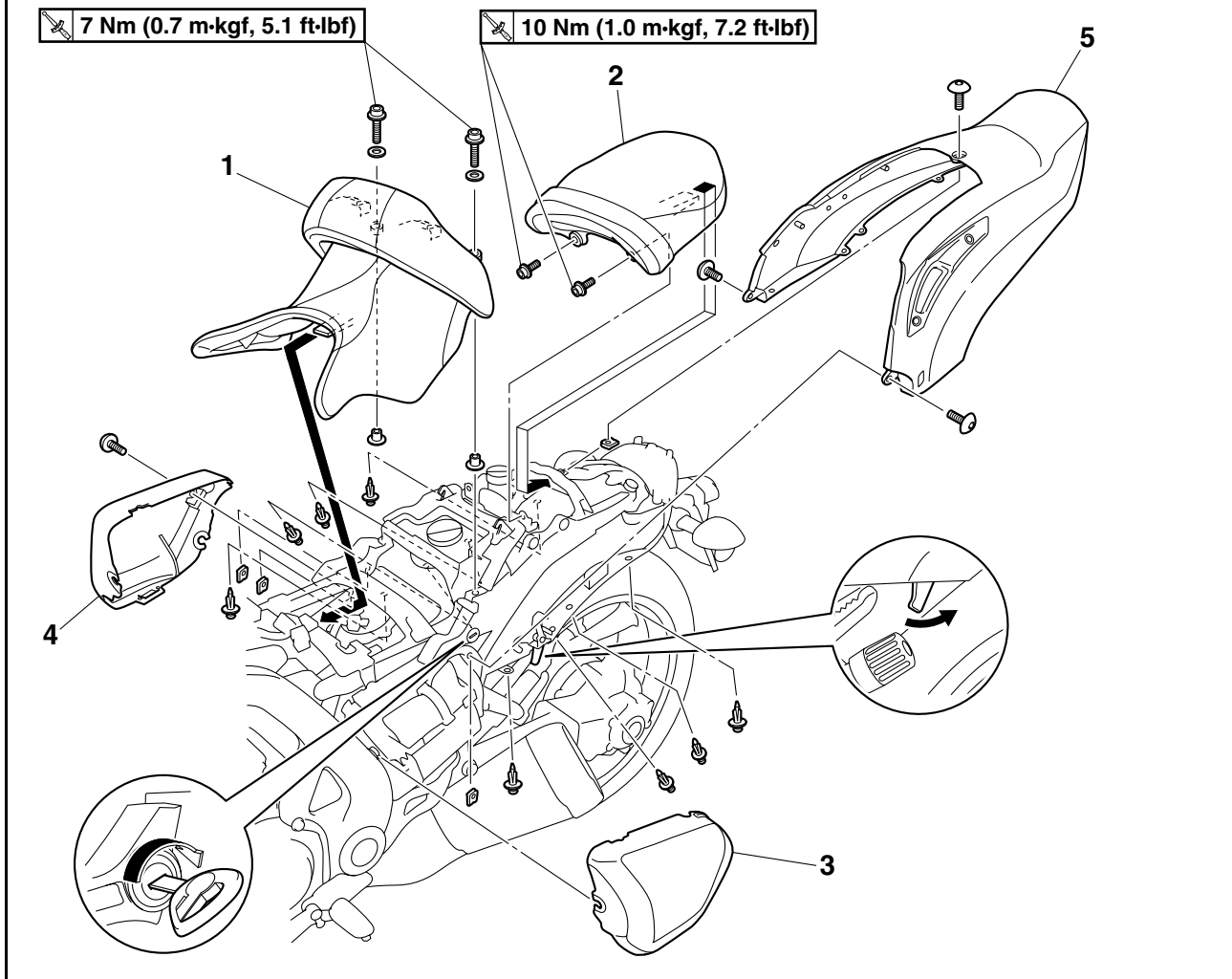

Order	Job/Parts to remove	Q'ty	Remarks
1	Rider seat	1	
2	Passenger seat	1	
3	Left side cover	1	
4	Right side cover	1	
5	Rear fender	1	
			For installation, reverse the removal procedure.

Removing the side cover inner panels, tail/brake light assembly, and rear turn signal light assembly

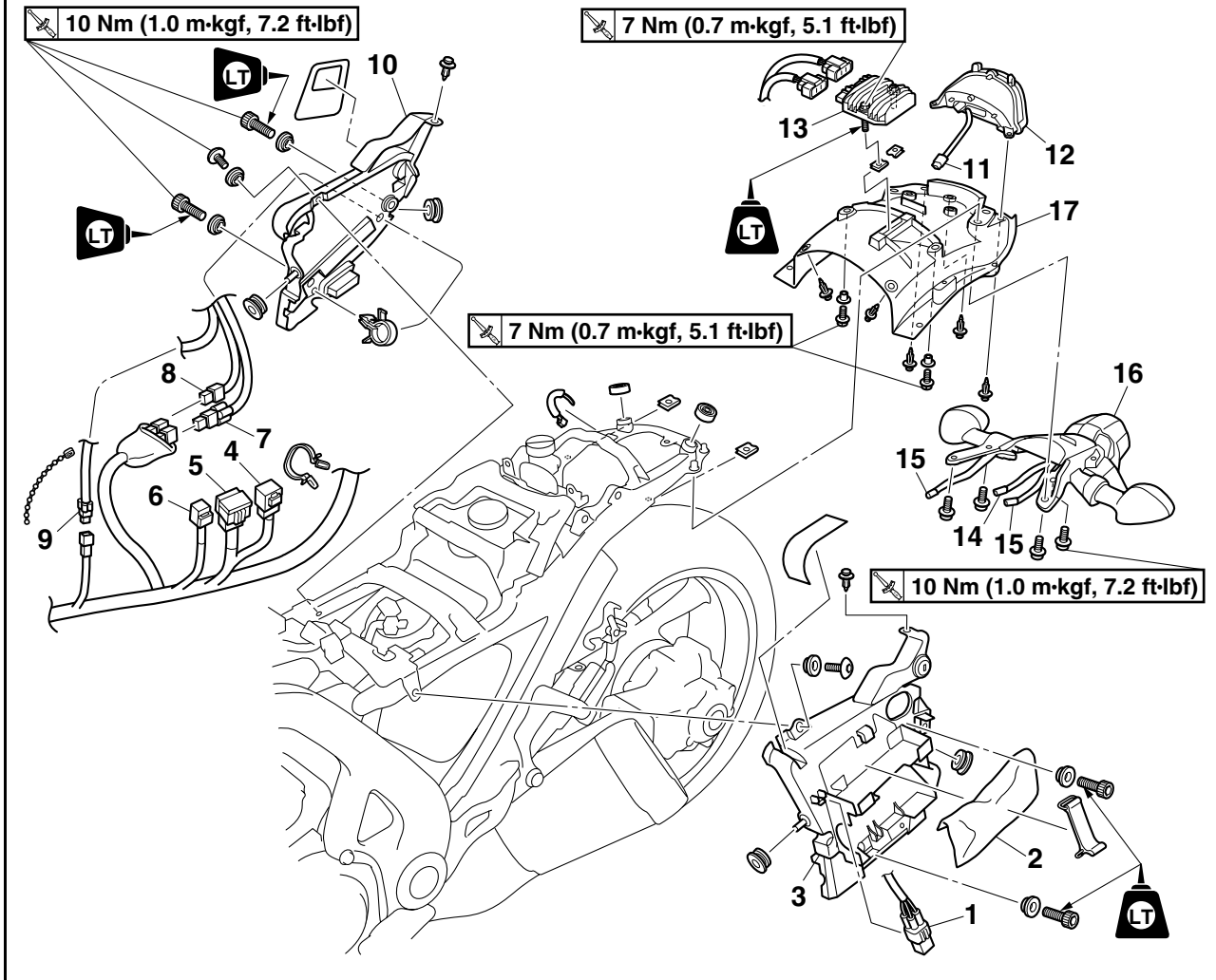

Order	Job/Parts to remove	Q'ty	Remarks
	Rear fender		Refer to "Removing the seats, side covers, and rear fender".
	Rollover valve		Refer to "FUEL TANK" on page 7-1.
	Canister		For California only Refer to "FUEL TANK" on page 7-1.
1	ABS test coupler	1	
2	Owner's tool kit	1	
3	Left side cover inner panel	1	
4	Relay unit	1	
5	Fuse box 1	1	
6	Turn signal/hazard relay	1	
7	O ₂ sensor coupler	1	Disconnect.
8	Rear brake light switch coupler	1	Disconnect.
9	Rear wheel sensor coupler	1	Disconnect.
10	Right side cover inner panel	1	
11	Tail/brake light coupler	1	Disconnect.
12	Tail/brake light assembly	1	
13	Rectifier/regulator	1	

Removing the side cover inner panels, tail/brake light assembly, and rear turn signal light assembly

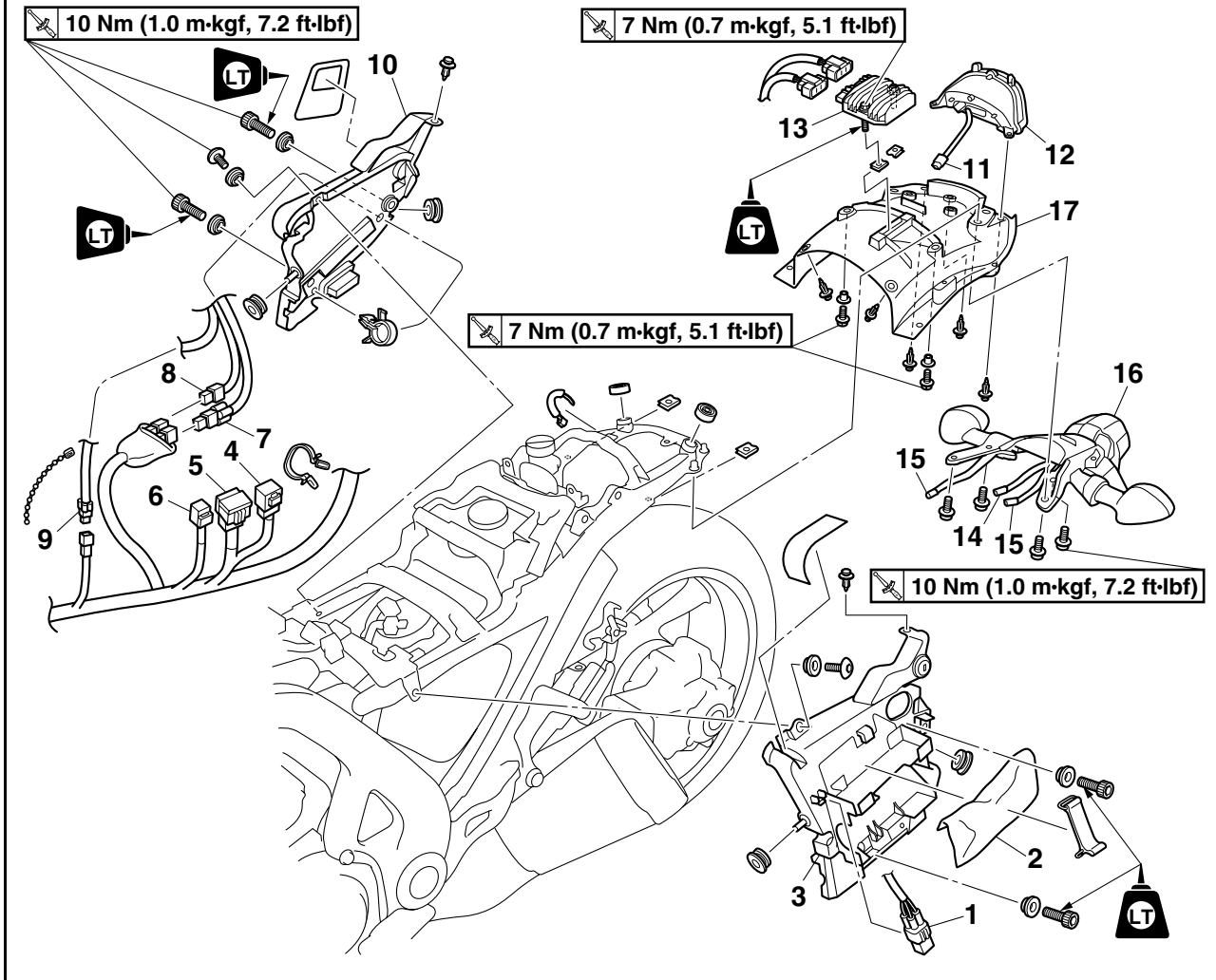

Order	Job/Parts to remove	Q'ty	Remarks
14	License plate light coupler	1	Disconnect.
15	Rear turn signal light coupler	2	Disconnect.
16	Rear turn signal light assembly	1	
17	Mudguard 1	1	
			For installation, reverse the removal procedure.

EAS2S31092

INSTALLING THE ABS TEST COUPLER

1. Install:

- ABS test coupler “1”

TIP

- Route the ABS test coupler lead through the slot “a” in the left side cover inner panel.
- Make sure that the ABS test coupler clasp faces inward, toward the left side cover inner panel.

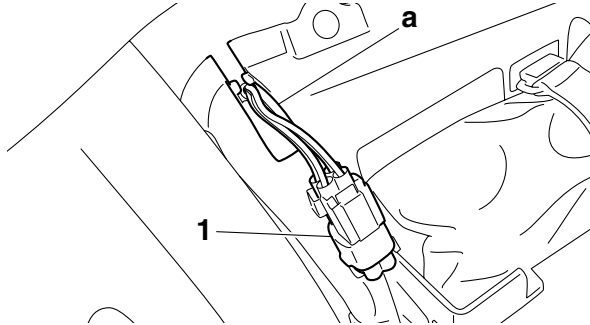

Removing the passenger footrests and mudguard 2

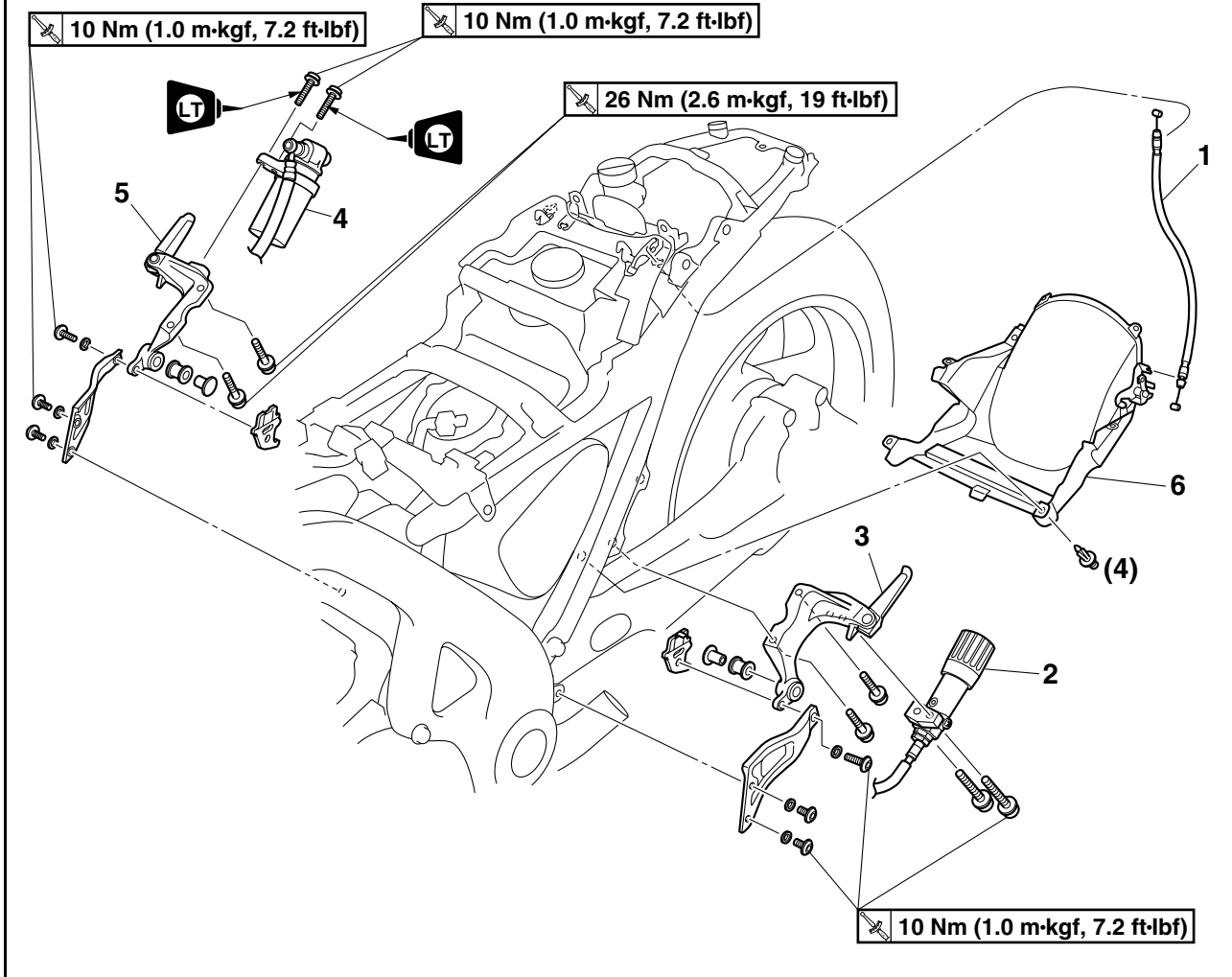

Order	Job/Parts to remove	Q'ty	Remarks
	Mudguard 1		Refer to "Removing the side cover inner panels, tail/brake light assembly, and rear turn signal light assembly".
	Mufflers/Exhaust chamber		Refer to "ENGINE REMOVAL" on page 5-1.
1	Seat lock cable	1	
2	Spring preload adjusting knob	1	
3	Left passenger footrest	1	
4	Gas tank (rear shock absorber assembly)	1	
5	Right passenger footrest	1	
6	Mudguard 2	1	
			For installation, reverse the removal procedure.

Removing the top cover, intake duct assemblies, and meter assembly 2

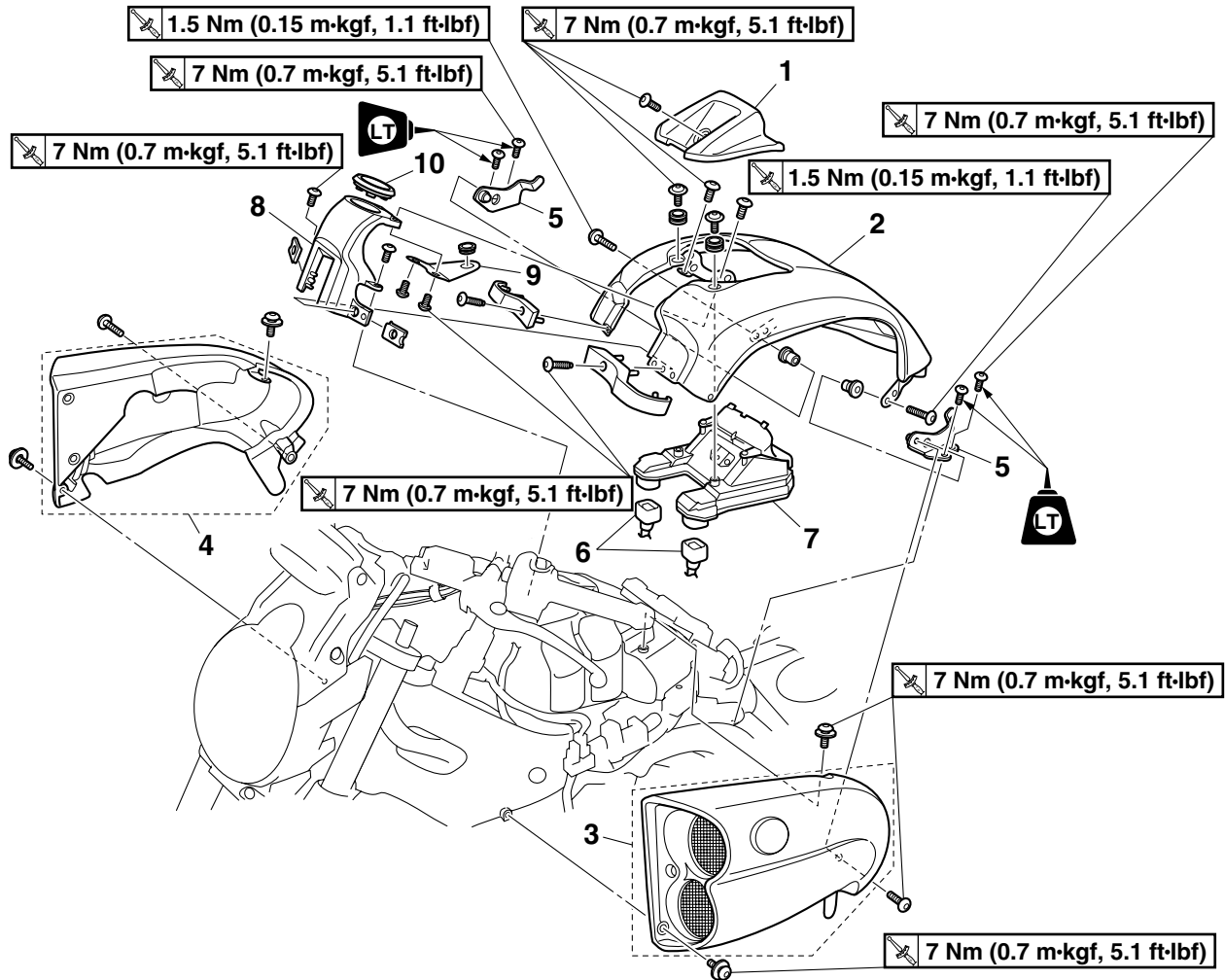

Order	Job/Parts to remove	Q'ty	Remarks
	Rider seat		Refer to "Removing the seats, side covers, and rear fender".
1	Meter assembly 2 cover	1	
2	Top cover	1	
3	Left intake duct assembly	1	
4	Right intake duct assembly	1	
5	Top cover bracket	2	
6	Meter assembly 2 coupler	2	Disconnect.
7	Meter assembly 2	1	
8	Main switch cover	1	
9	Meter assembly 2 bracket	1	
10	Main switch bezel	1	
			For installation, reverse the removal procedure.

Disassembling the intake duct assemblies

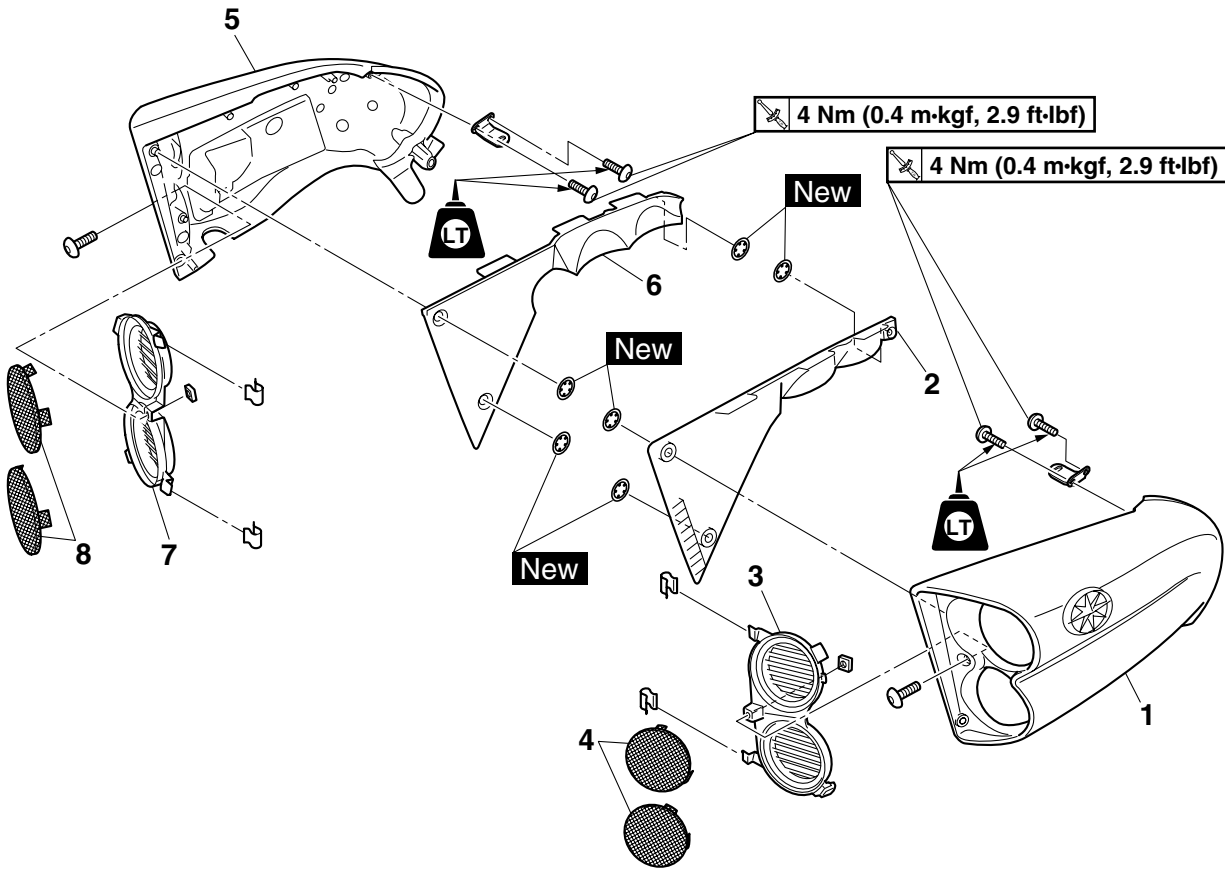

Order	Job/Parts to remove	Q'ty	Remarks
1	Left intake duct	1	
2	Left intake duct inner plate	1	
3	Left intake grill	1	
4	Left intake dust filter	2	
5	Right intake duct	1	
6	Right intake duct inner plate	1	
7	Right intake grill	1	
8	Right intake dust filter	2	
			For assembly, reverse the disassembly procedure.

Removing the battery

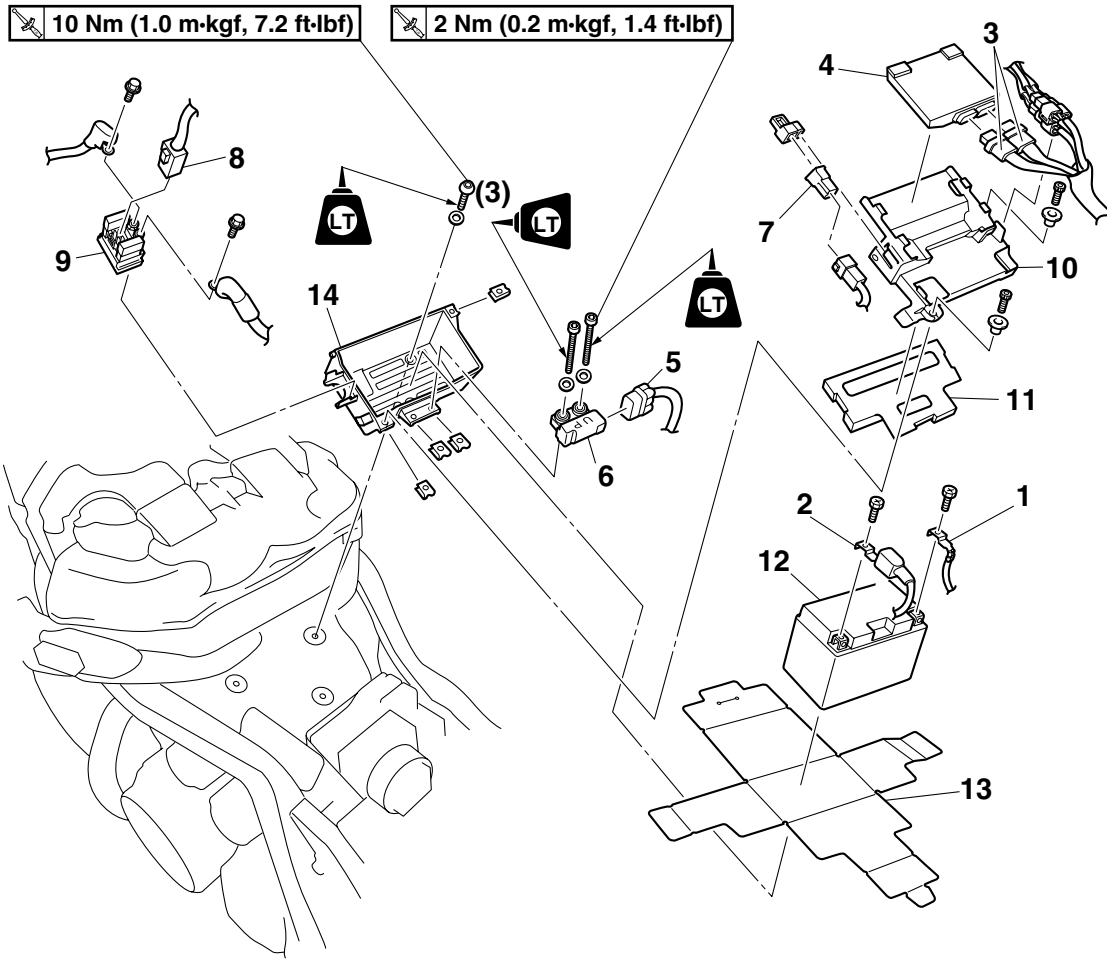

Order	Job/Parts to remove	Q'ty	Remarks
	Top cover		Refer to "Removing the top cover intake duct assemblies, and meter assembly 2".
1	Negative battery lead	1	Disconnect.
2	Positive battery lead	1	Disconnect.
3	ECU coupler	2	Disconnect.
4	ECU (engine control unit)	1	
5	Lean angle sensor coupler	1	Disconnect.
6	Lean angle sensor	1	
7	Main fuse	1	
8	Starter relay coupler	1	Disconnect.
9	Starter relay	1	
10	ECU tray	1	
11	Battery cover	1	
12	Battery	1	
13	Battery seat	1	
14	Battery box	1	
			For installation, reverse the removal procedure.

EAS2S31032

INSTALLING THE BATTERY

1. Install:

- Battery seat “1”
(to the battery “2”)

TIP

Install the battery seat as shown in the illustration.

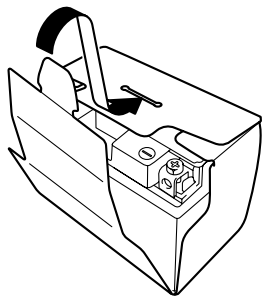
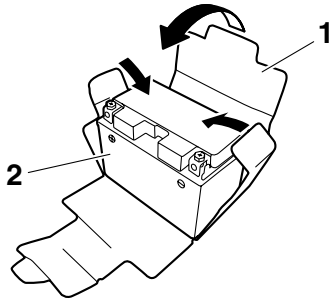

2. Install:

- Positive battery lead “1”
- Negative battery lead “2”

ECA2S31067

NOTICE

First, connect the positive battery lead “1”, then the negative battery lead “2”.

TIP

Pass the positive battery lead through the guide on the battery box.

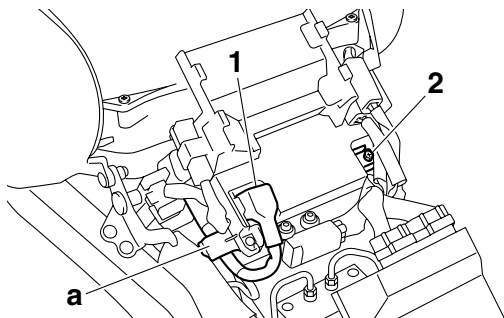

Removing the meter assembly 1 and headlight

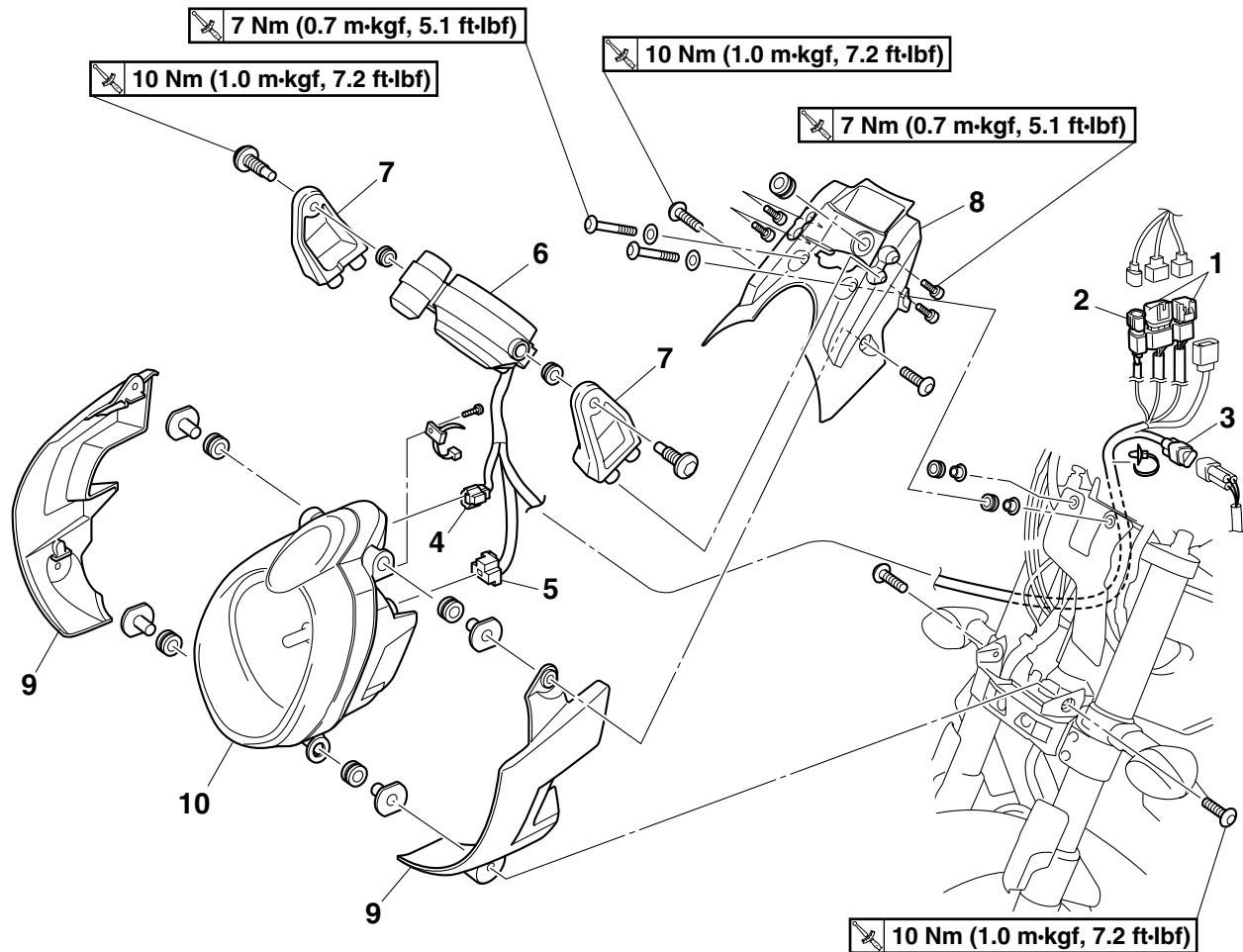

Order	Job/Parts to remove	Q'ty	Remarks
	Lower air filter case		Refer to "AIR FILTER CASE" on page 7-6.
1	Meter assembly 1 coupler	2	Disconnect.
2	Meter assembly 1 sub-wire harness coupler	1	Disconnect.
3	SELECT/RESET button unit coupler	1	Disconnect.
4	Auxiliary light coupler	1	Disconnect.
5	Headlight coupler	1	Disconnect.
6	Meter assembly 1	1	
7	Meter assembly 1 bracket	2	
8	Headlight top cover	1	
9	Headlight side cover	2	
10	Headlight lens unit	1	
			For installation, reverse the removal procedure.

EAS21880

FRONT WHEEL

Removing the front wheel, brake discs, wheel sensor and sensor housing

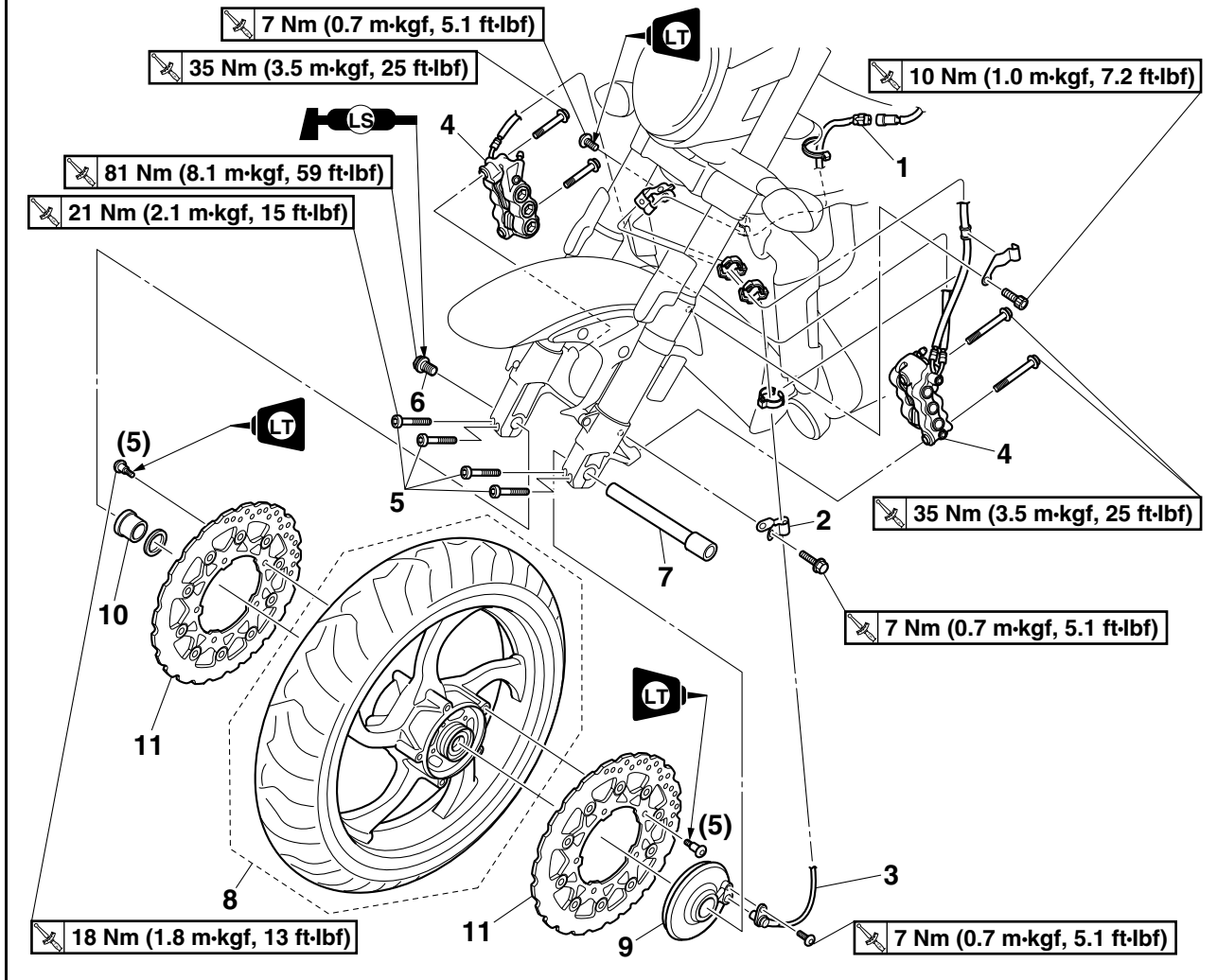

Order	Job/Parts to remove	Q'ty	Remarks
	Rider seat		Refer to "GENERAL CHASSIS" on page 4-1.
	Lower air filter case		Refer to "AIR FILTER CASE" on page 7-6.
1	Front wheel sensor coupler	1	Disconnect.
2	Front wheel sensor lead holder	1	
3	Front wheel sensor	1	
4	Front brake caliper	2	
5	Front wheel axle pinch bolt	4	Loosen.
6	Front wheel axle bolt	1	
7	Front wheel axle	1	
8	Front wheel	1	
9	Front wheel sensor housing	1	
10	Collar	1	
11	Front brake disc	2	
			For installation, reverse the removal procedure.

FRONT WHEEL

Disassembling the front wheel

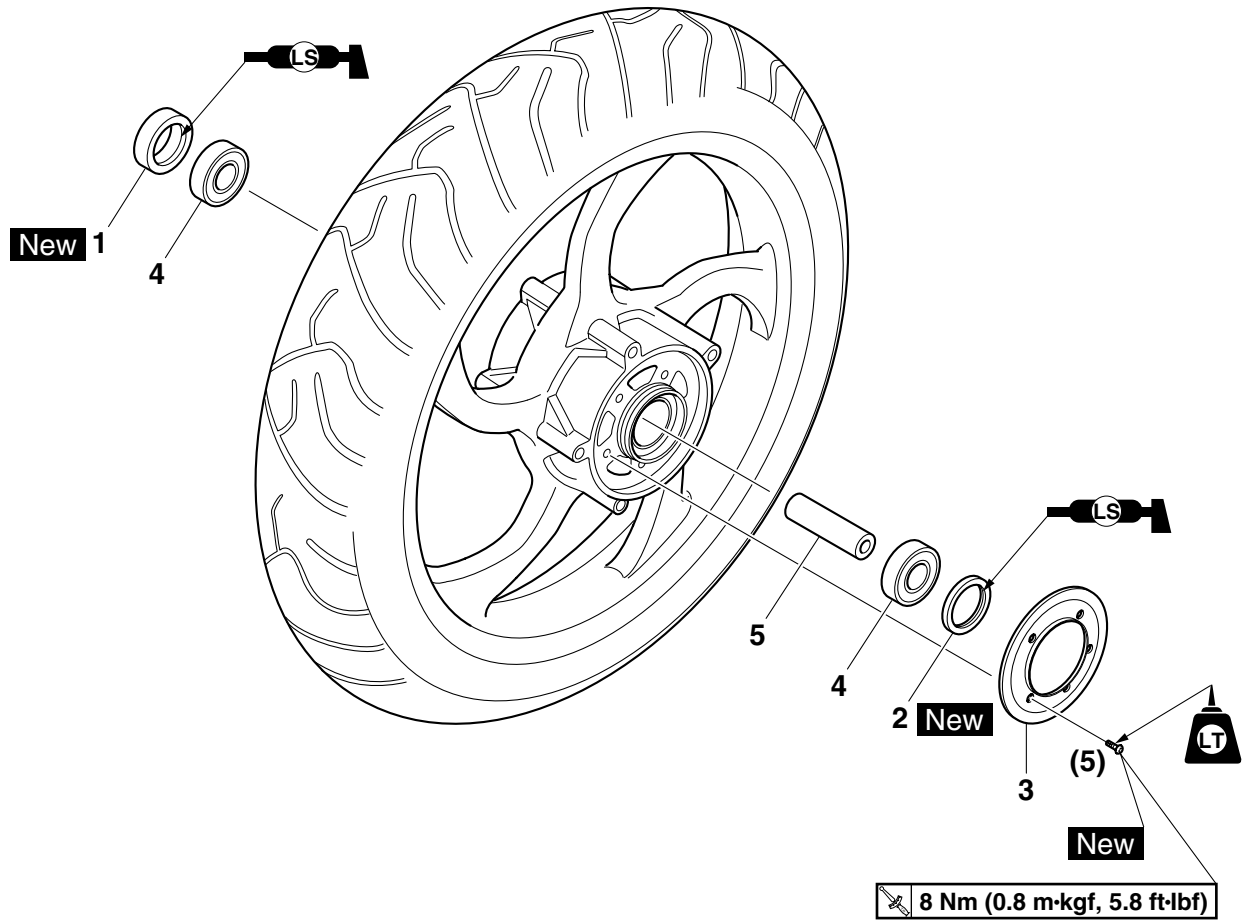

Order	Job/Parts to remove	Q'ty	Remarks
1	Oil seal	1	
2	Oil seal	1	
3	Front wheel sensor rotor	1	
4	Wheel bearing	2	
5	Spacer	1	
			For assembly, reverse the disassembly procedure.

EAS21900

REMOVING THE FRONT WHEEL

ECA2S31007

NOTICE

Keep magnets (including magnetic pick-up tools, magnetic screwdrivers, etc.) away from the front wheel hub "1", otherwise the wheel sensor rotor equipped in the wheel hub may be damaged, resulting in improper performance of the ABS system.

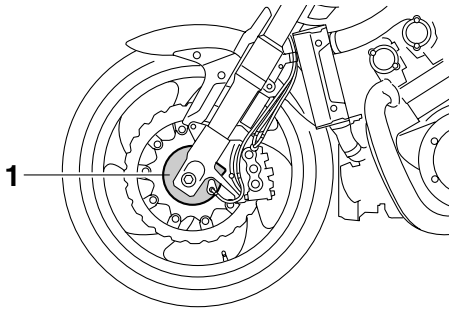

1. Stand the vehicle on a level surface.

EWA13120

WARNING

Securely support the vehicle so that there is no danger of it falling over.

2. Remove:
 - Front brake calipers

TIP

Do not apply the brake lever when removing the brake calipers.

3. Elevate:
 - Front wheel

TIP

Place the vehicle on a suitable stand so that the front wheel is elevated.

EAS21910

DISASSEMBLING THE FRONT WHEEL

ECA2S31008

NOTICE

- Keep magnets (including magnetic pick-up tools, magnetic screwdrivers, etc.) away from the wheel sensor rotor.
- Do not drop the wheel sensor rotor or subject it to shocks.
- If any solvent gets on the wheel sensor rotor, wipe it off immediately.

1. Remove:
 - Oil seals
 - Wheel bearings

- a. Clean the surface of the front wheel hub.

- b. Remove the oil seals "1" with a flat head screwdriver.

TIP

To prevent damaging the wheel or wheel sensor rotor, place a rag "2" between the screwdriver and the surface of the wheel or rotor.

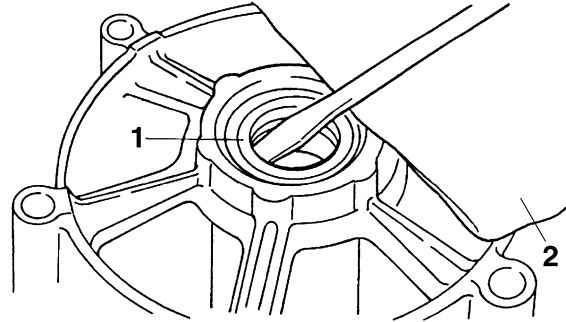

- c. Remove the wheel sensor rotor.
- d. Remove the wheel bearings "3" with a general bearing puller.

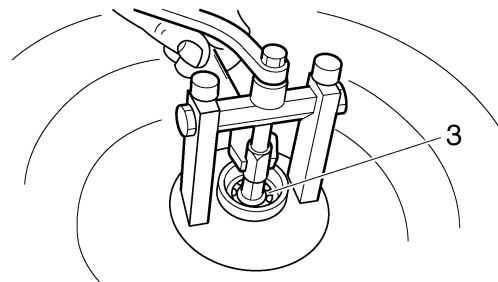

EAS21920

CHECKING THE FRONT WHEEL

1. Check:
 - Wheel axle
 - Roll the wheel axle on a flat surface.
 - Bends → Replace.

EWA13460

WARNING

Do not attempt to straighten a bent wheel axle.

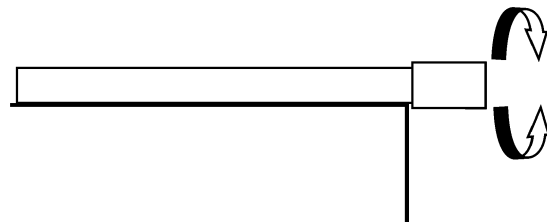

2. Check:
 - Tire

- Front wheel
Damage/wear → Replace.
Refer to “CHECKING THE TIRES” on page 3-31 and “CHECKING THE WHEELS” on page 3-32.

3. Measure:

- Radial wheel runout “1”
- Lateral wheel runout “2”
Over the specified limits → Replace.



Radial wheel runout limit
1.0 mm (0.04 in)
Lateral wheel runout limit
0.5 mm (0.02 in)

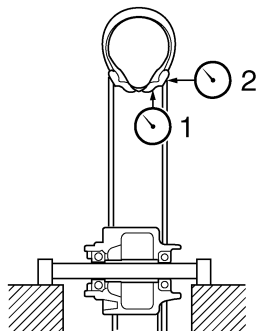

4. Check:

- Wheel bearings
Front wheel turns roughly or is loose → Replace the wheel bearings.
- Oil seals
Damage/wear → Replace.

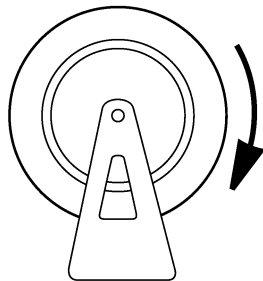

- **Keep magnets (including magnetic pick-up tools, magnetic screwdrivers, etc.) away from the wheel sensor rotor.**
- **Do not drop or shock the wheel sensor or the wheel sensor rotor.**

1. Check:

- Front wheel sensor “1”
Cracks/bends/distortion → Replace.
Iron powder/dust → Clean.

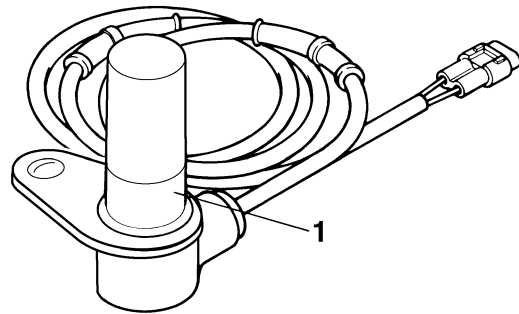

2. Check:

- Front wheel sensor rotor “1”
Cracks/damage/scratches → Replace the front wheel sensor rotor.
Iron powder/dust/solvent → Clean.

TIP

- The wheel sensor rotor is installed on the inner side of the wheel hub.
- When cleaning the wheel sensor rotor, be careful not to damage the surface of the rotor magnet.

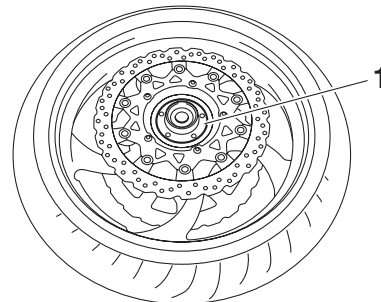

EAS22010

MAINTENANCE OF THE FRONT WHEEL SENSOR AND SENSOR ROTOR

ECA2S31009

NOTICE

- **Handle the ABS components with care since they have been accurately adjusted. Keep them away from dirt and do not subject them to shocks.**
- **The front wheel sensor cannot be disassembled. Do not attempt to disassemble it. If faulty, replace with a new one.**

3. Measure:

- Wheel sensor rotor deflection
Out of specification → Clean the installation surface of the wheel sensor rotor and correct the wheel sensor rotor deflection, or replace the wheel sensor rotor.



Wheel sensor rotor deflection limit
0.14 mm (0.0055 in)

- a. Turn the front wheel and make sure it stays at each position shown.

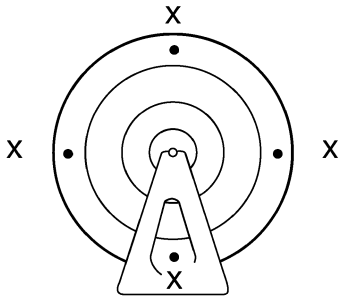

- b. If the front wheel does not remain stationary at all of the positions, rebalance it.

EAS22000

INSTALLING THE FRONT WHEEL (FRONT BRAKE DISCS)

1. Install:

- Front brake discs



Front brake disc bolt
18 Nm (1.8 m·kgf, 13 ft·lbf)
LOCTITE®

TIP

Tighten the brake disc bolts in stages and in a crisscross pattern.

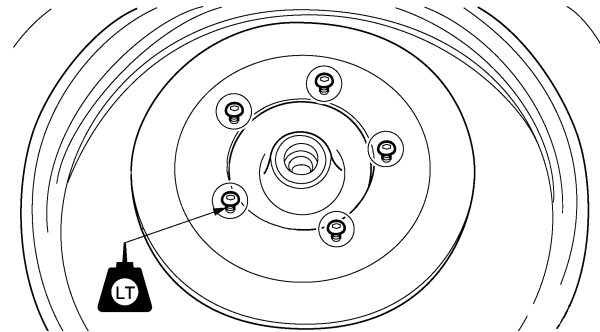

2. Check:

- Front brake discs

Refer to “CHECKING THE FRONT BRAKE DISCS” on page 4-34.

3. Lubricate:

- Oil seal lips

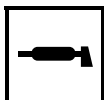

Recommended lubricant
Lithium-soap-based grease

4. Install:

- Collar
- Front wheel sensor housing
- Front wheel

TIP

Align the slot in the front wheel sensor housing with the projection of the front fork before assembly.

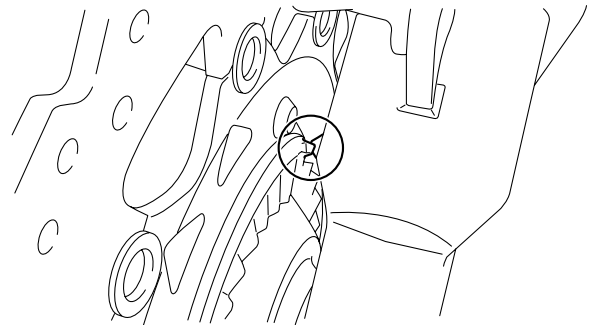

5. Install:

- Front wheel axle
- Front wheel axle bolt
- Front wheel axle pinch bolts



Front wheel axle bolt
81 Nm (8.1 m·kgf, 59 ft·lbf)
Front wheel axle pinch bolt
21 Nm (2.1 m·kgf, 15 ft·lbf)

ECA2S31013

NOTICE

Before tightening the wheel axle bolt, push down hard on the handlebars several times and check if the front fork rebounds smoothly.

TIP

Lubricate the front wheel axle bolt seats with lithium-soap-based grease.

- a. Insert the front wheel axle from the left side and tighten it with the front wheel axle bolt from the right side to 81 Nm (8.1 m·kgf, 59 ft·lbf).
- b. In the order pinch bolt “2” → pinch bolt “1” → pinch bolt “2”, tighten each bolt to 21 Nm (2.1 m·kgf, 15 ft·lbf) without performing temporary tightening.
- c. Check that the left end of the front wheel axle is flush with the front fork. If necessary, manually push the front wheel axle or lightly tap it with a soft hammer until its end is flush with the front fork. However, if the surface of the front wheel axle end is not parallel to the surface of the front fork, align a point on the outer edge of the axle with the fork, making sure that the axle does not protrude past the fork.

- d. In the order pinch bolt “3” → pinch bolt “4” → pinch bolt “3”, tighten each bolt to 21 Nm (2.1 m·kgf, 15 ft·lbf) without performing temporary tightening.

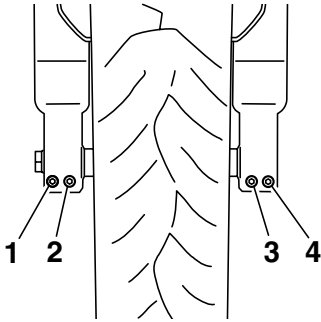

6. Measure:

TIP

Measure the distance “a” only if the wheel bearings, wheel sensor rotor, or both were replaced.

- Distance “a”
(between the wheel sensor rotor “1” and wheel sensor housing “2”)
Out of specification → Reinstall the bearing or replace the wheel sensor rotor.



Distance “a” (between the wheel sensor rotor and wheel sensor housing)
29.2–29.5 mm (1.15–1.16 in)

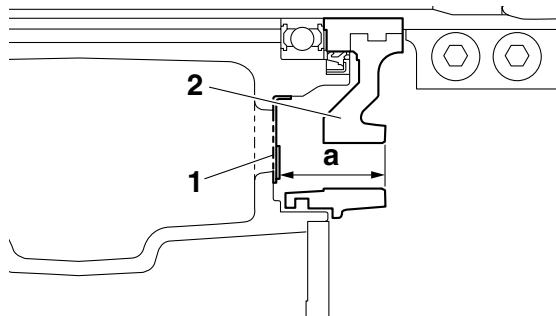

7. Install:

- Front brake calipers
- Front wheel sensor
- Front wheel sensor lead holder



Front brake caliper bolt
35 Nm (3.5 m·kgf, 25 ft·lbf)
Front wheel sensor bolt
7 Nm (0.7 m·kgf, 5.1 ft·lbf)
Front wheel sensor lead holder bolt
7 Nm (0.7 m·kgf, 5.1 ft·lbf)

TIP

- When installing the front wheel sensor, check the wheel sensor lead for twists and the sensor electrode for foreign materials.
- Install the front wheel sensor lead holder with the “UP” mark facing up and to the inside.

ECA2S31014

NOTICE

- **Make sure there are no foreign materials in the wheel hub. Foreign materials cause damage to the inner sensor rotor and wheel sensor.**
- **To route the front wheel sensor lead, refer to “CABLE ROUTING” on page 2-47.**

EWA13500

WARNING

Make sure the brake hose is routed properly.

8. Check:

- Front wheel sensor installation
Check if the wheel sensor housing is installed properly.

EAS22030

REAR WHEEL

Removing the rear wheel, brake disc, wheel sensor, and sensor housing

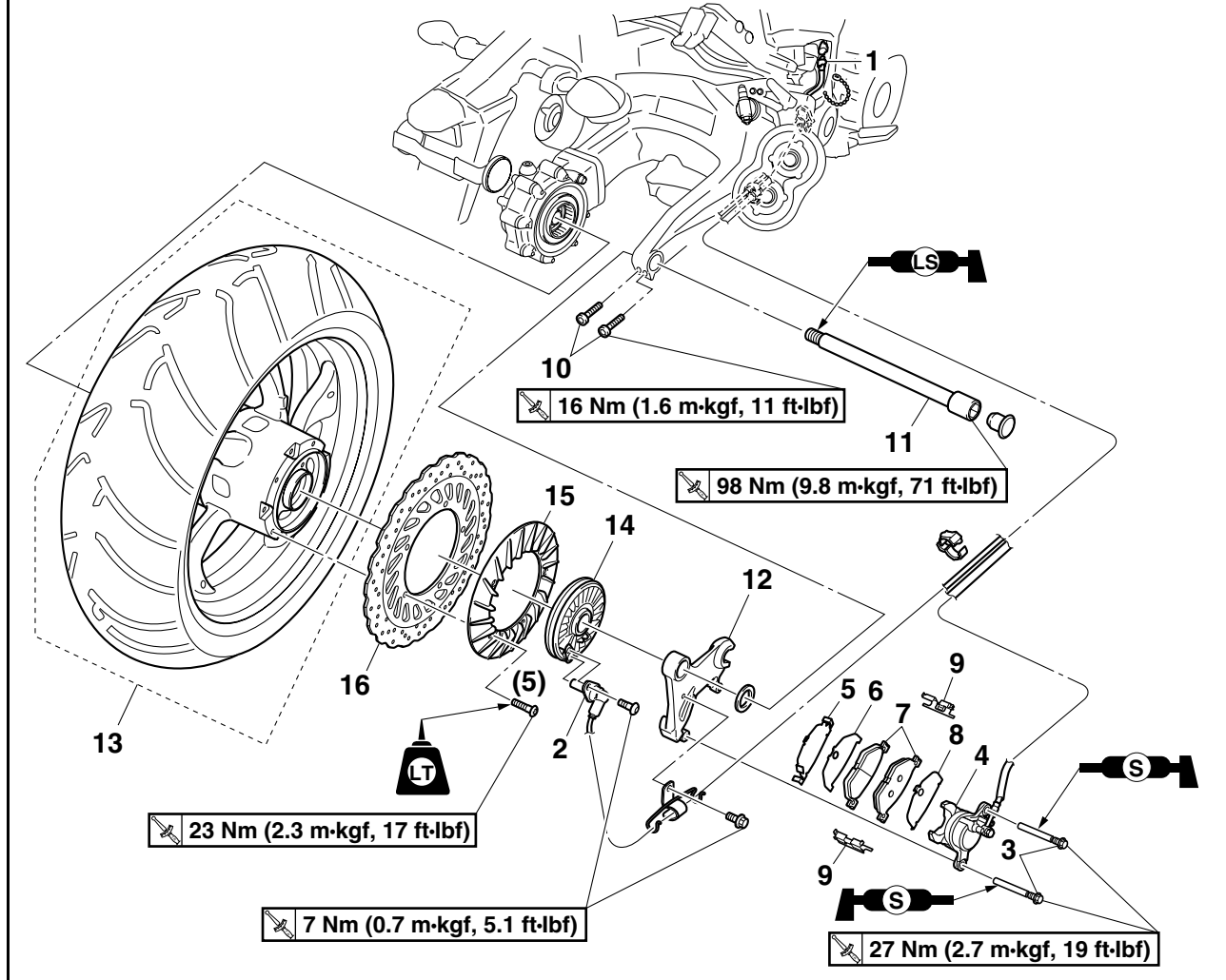

Order	Job/Parts to remove	Q'ty	Remarks
	Right side cover		Refer to "GENERAL CHASSIS" on page 4-1.
1	Rear wheel sensor coupler	1	Disconnect.
2	Rear wheel sensor	1	
3	Rear brake caliper retaining bolt	2	
4	Rear brake caliper	1	
5	Brake pad shim	1	
6	Brake pad insulator	1	Left side only.
7	Rear brake pad	2	
8	Brake pad shim	1	
9	Brake pad support	2	
10	Rear wheel axle pinch bolt	2	Loosen.
11	Rear wheel axle	1	
12	Rear brake caliper bracket	1	
13	Rear wheel	1	
14	Rear wheel sensor housing	1	

Removing the rear wheel, brake disc, wheel sensor, and sensor housing

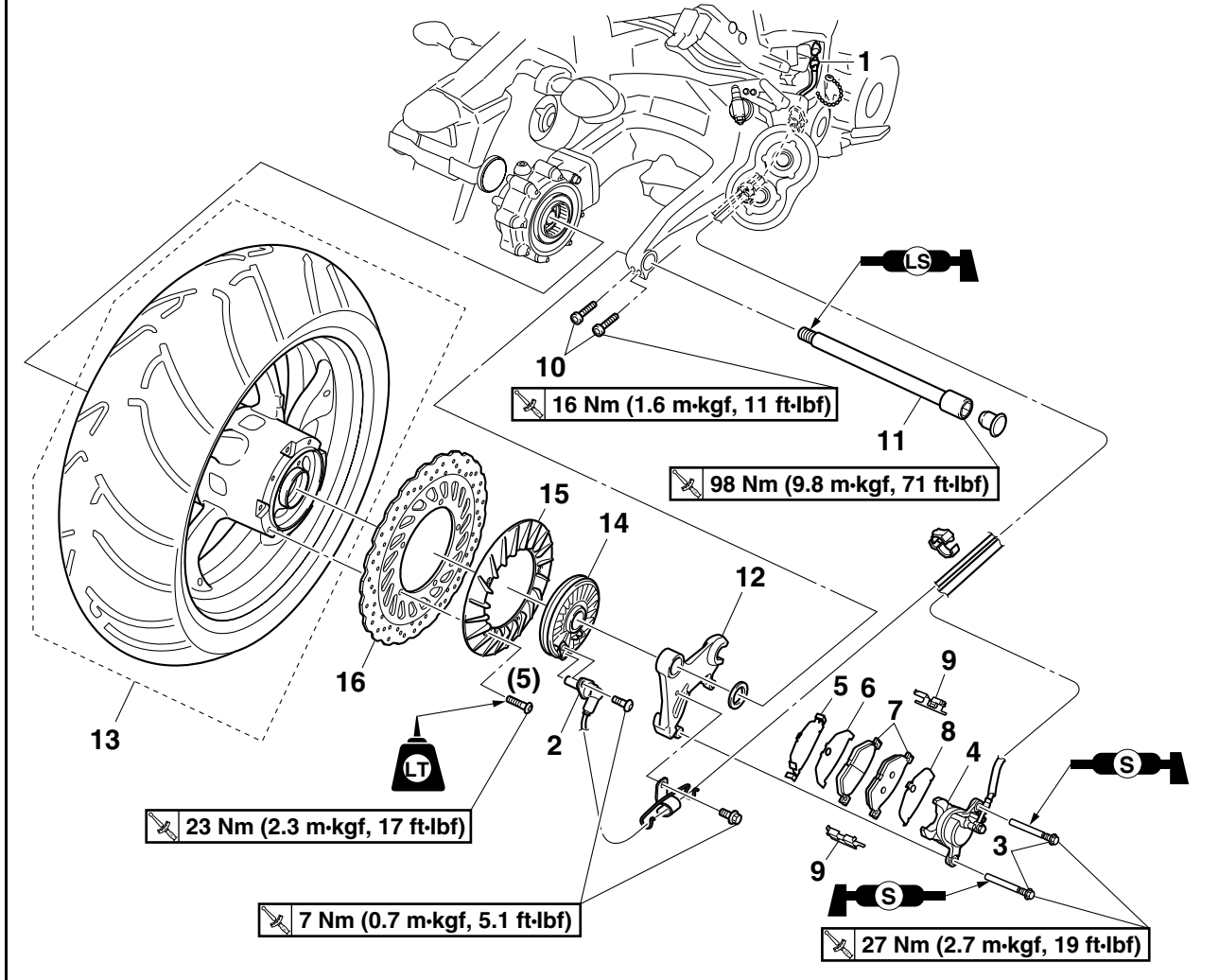

Order	Job/Parts to remove	Q'ty	Remarks
15	Rear brake disc cover	1	
16	Rear brake disc	1	
			For installation, reverse the removal procedure.

REAR WHEEL

Disassembling the rear wheel

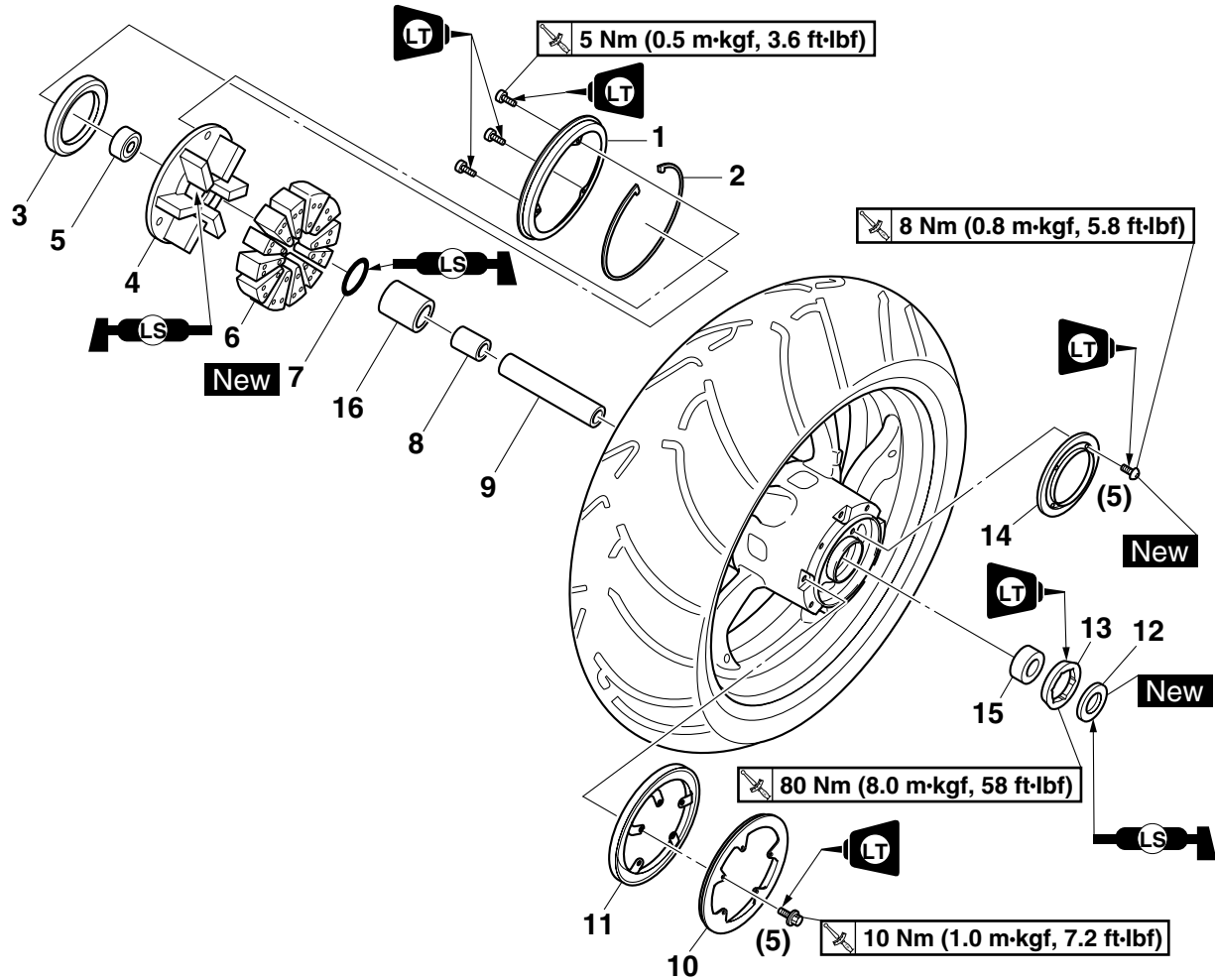

Order	Job/Parts to remove	Q'ty	Remarks
1	Dust cover	1	
2	Rear wheel drive hub stopper	1	
3	Dust seal	1	
4	Rear wheel drive hub	1	
5	Wheel bearing	1	
6	Rear wheel drive hub damper	6	
7	O-ring	1	
8	Spacer	1	
9	Spacer	1	
10	Rear wheel ring plate	1	
11	Rear wheel ring	1	
12	Oil seal	1	
13	Bearing retainer	1	
14	Rear wheel sensor rotor	1	
15	Wheel bearing	1	
16	Bearing	1	
			For assembly, reverse the disassembly procedure.

EAS22050

REMOVING THE REAR WHEEL (DISC)

ECA2S31015

NOTICE

Keep magnets (including magnetic pick-up tools, magnetic screwdrivers, etc.) away from the rear wheel hub "1", otherwise the wheel sensor rotor equipped in the wheel hub may be damaged, resulting in improper performance of the ABS system.

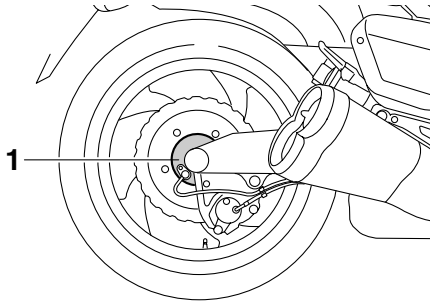

1. Stand the vehicle on a level surface.

EWA13120

WARNING

Securely support the vehicle so that there is no danger of it falling over.

TIP

Place the vehicle on a suitable stand so that the rear wheel is elevated.

2. Remove:

- Rear wheel sensor
- Rear brake caliper retaining bolt
- Rear brake caliper

ECA2S31016

NOTICE

- Do not operate the brake pedal when removing the brake caliper.
- Be sure to remove the rear wheel sensor before removing the rear wheel sensor housing; otherwise, the sensor could be damaged.

3. Remove:

- Rear wheel axle "1"

TIP

Remove the rear wheel axle with the damper rod holder (24 mm) "2".



Damper rod holder (24 mm)
90890-01328
YM-01328

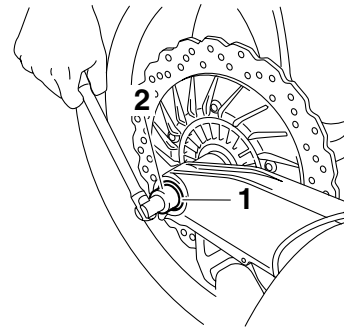

4. Remove:

- Rear wheel

TIP

Move the rear wheel to the right to separate it from the final drive assembly.

EAS2S31021

DISASSEMBLING THE REAR WHEEL

ECA2S31008

NOTICE

- Keep magnets (including magnetic pick-up tools, magnetic screwdrivers, etc.) away from the wheel sensor rotor.
- Do not drop the wheel sensor rotor or subject it to shocks.
- If any solvent gets on the wheel sensor rotor, wipe it off immediately.

1. Remove:

- Oil seal
- Bearing retainer
- Wheel bearings

- a. Clean the surface of the rear wheel hub.
- b. Remove the oil seal "1" with a flathead screwdriver.

TIP

To prevent damaging the wheel or wheel sensor rotor, place a rag "2" between the screwdriver and the surface of the wheel or rotor.

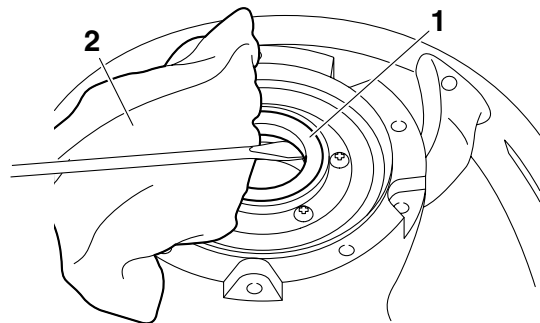

- c. Loosen the bearing retainer "1" with a hexagon wrench (41) "2".

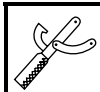

Hexagon wrench (41)
90890-01525
YM-01525

ECA2S31017

NOTICE

The bearing retainer has left-handed threads. To loosen the retainer, turn it clockwise.

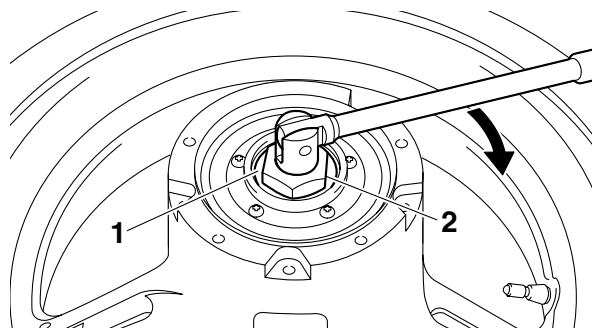

- d. Remove the wheel sensor rotor.
- e. Remove the wheel bearings "1" with a general bearing puller.

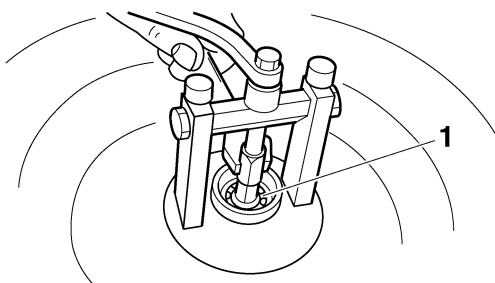

EAS22090

CHECKING THE REAR WHEEL

1. Check:
 - Wheel axle
 - Wheel bearings
 - Oil seal
 Refer to "CHECKING THE FRONT WHEEL" on page 4-14.
2. Check:
 - Tire
 - Rear wheel
 Damage/wear → Replace.
 Refer to "CHECKING THE TIRES" on page 3-31 and "CHECKING THE WHEELS" on page 3-32.
3. Measure:
 - Radial wheel runout

- Lateral wheel runout
 Refer to "CHECKING THE FRONT WHEEL" on page 4-14.



Radial wheel runout limit
1.0 mm (0.04 in)
Lateral wheel runout limit
0.5 mm (0.02 in)

EAS22200

MAINTENANCE OF THE REAR WHEEL SENSOR AND SENSOR ROTOR

ECA2S31018

NOTICE

- Handle the ABS components with care since they have been accurately adjusted. Keep them away from dirt and do not subject them to shocks.
- The rear wheel sensor cannot be disassembled. Do not attempt to disassemble it. If faulty, replace with a new one.
- Keep magnets (including magnetic pick-up tools, magnetic screwdrivers, etc.) away from the wheel sensor rotor.
- Do not drop or shock the wheel sensor or the wheel sensor rotor.

1. Check:
 - Rear wheel sensor
 Refer to "MAINTENANCE OF THE FRONT WHEEL SENSOR AND SENSOR ROTOR" on page 4-15.
2. Check:
 - Rear wheel sensor rotor
 Refer to "MAINTENANCE OF THE FRONT WHEEL SENSOR AND SENSOR ROTOR" on page 4-15.
3. Measure:
 - Wheel sensor rotor deflection
 Refer to "MAINTENANCE OF THE FRONT WHEEL SENSOR AND SENSOR ROTOR" on page 4-15.

EAS22140

ASSEMBLING THE REAR WHEEL

ECA2S31008

NOTICE

- Keep magnets (including magnetic pick-up tools, magnetic screwdrivers, etc.) away from the wheel sensor rotor.
- Do not drop the wheel sensor rotor or subject it to shocks.
- If any solvent gets on the wheel sensor rotor, wipe it off immediately.

1. Install:
 - Bearing "1"



Installed depth of bearing "a"
9.6–10.6 mm (0.38–0.42 in)

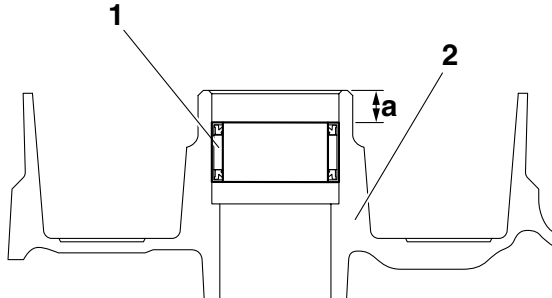

2. Rear wheel

2. Install:
 - Wheel bearings **New**

- a. Install the new wheel bearings in the reverse order of disassembly.

ECA2S31011

NOTICE

Do not contact the wheel bearing inner race "1" or balls "2". Contact should be made only with the outer race "3".

TIP

Use a socket "4" that matches the diameter of the wheel bearing outer race.

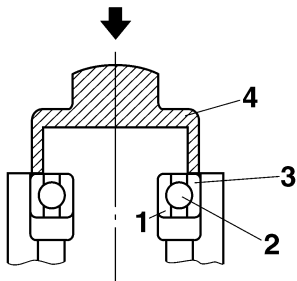

3. Install:
 - Rear wheel sensor rotor



Rear wheel sensor rotor bolt
8 Nm (0.8 m·kgf, 5.8 ft·lbf)
LOCTITE®

ECA2S31010

NOTICE

Replace the wheel sensor rotor bolts with new ones.

4. Install:
 - Bearing retainer

- a. Tighten the bearing retainer "1" with a hexagon wrench (41) "2".



Hexagon wrench (41)
90890-01525
YM-01525



Bearing retainer
80 Nm (8.0 m·kgf, 58 ft·lbf)
LOCTITE®

ECA2S31020

NOTICE

The bearing retainer has left-handed threads. To tighten the retainer, turn it counterclockwise.

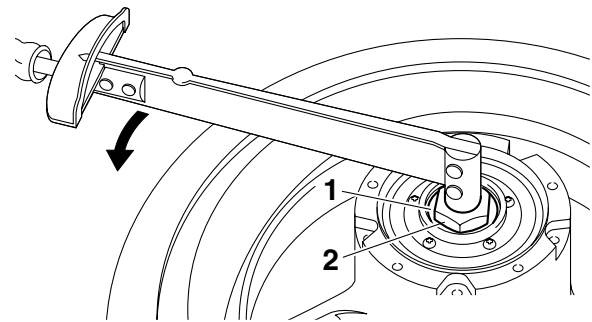

5. Install:
 - Rear wheel drive hub "1"
 - Dust seal
 - Rear wheel drive hub stopper "2"
 - Dust cover



Rear wheel drive hub bolt
5 Nm (0.5 m·kgf, 3.6 ft·lbf)
LOCTITE®

TIP

Install the rear wheel drive hub so that the projection "a" fits between the ends "b" of the rear wheel drive hub stopper.

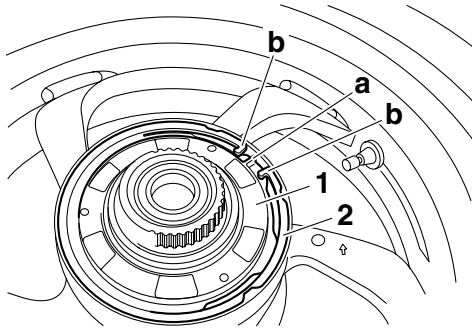

6. Measure:
- Wheel sensor rotor deflection
Out of specification → Correct the wheel sensor rotor deflection or replace the wheel sensor rotor.
Refer to “MAINTENANCE OF THE REAR WHEEL SENSOR AND SENSOR ROTOR” on page 4-24.

	<p>Wheel sensor rotor deflection limit 0.14 mm (0.0055 in)</p>
--	---

EAS22150

ADJUSTING THE REAR WHEEL STATIC BALANCE

TIP

- After replacing the tire, wheel or both, the rear wheel static balance should be adjusted.
- Adjust the rear wheel static balance with the brake disc and rear wheel drive hub installed.

1. Adjust:

- Rear wheel static balance
Refer to “ADJUSTING THE FRONT WHEEL STATIC BALANCE” on page 4-17.

EAS22170

INSTALLING THE REAR WHEEL (REAR BRAKE DISC)

1. Install:

- Rear brake disc
- Rear brake disc cover

	<p>Rear brake disc bolt 23 Nm (2.3 m·kgf, 17 ft·lbf) LOCTITE®</p>
--	--

TIP

Tighten the brake disc bolts in stages and in a crisscross pattern.

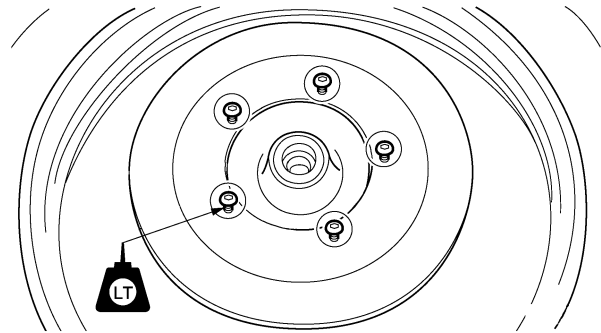

2. Check:
- Rear brake disc
Refer to “CHECKING THE REAR BRAKE DISC” on page 4-47.
3. Lubricate:
- Oil seal lips

	<p>Recommended lubricant Lithium-soap-based grease</p>
--	---

4. Install:

- Rear wheel sensor housing
- Rear wheel
- Rear brake caliper bracket
- Rear wheel axle

TIP

- Do not install the brake pad supports, brake pads, brake pad insulator, brake pad shims, and brake caliper.
- Align the slot “a” of the rear wheel sensor housing “1” with the projection “b” of the rear brake caliper bracket “2”, and then assemble them.
- Fit the brake torque stop pin “3” on the swing-arm into the slot “c” on the rear brake caliper bracket.
- After assembling the rear wheel sensor housing and the rear brake caliper bracket, make sure that the projection “d” on the housing is aligned with the projection “e” on the bracket.

ECA14470

NOTICE

Make sure there are no foreign materials in the wheel hub. Foreign materials cause damage to the inner sensor rotor and wheel sensor.

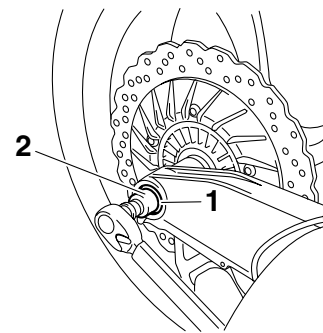
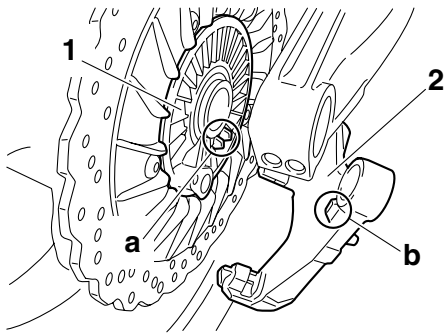

b. In the order pinch bolt “3” → pinch bolt “4” → pinch bolt “3”, tighten each bolt to 16 Nm (1.6 m·kgf, 11 ft·lbf) without performing temporary tightening.

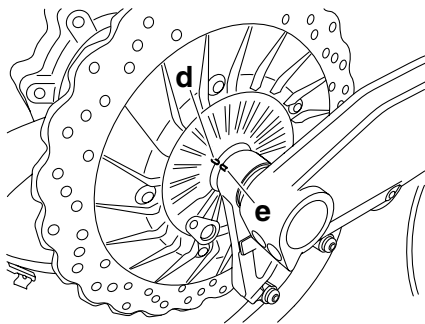
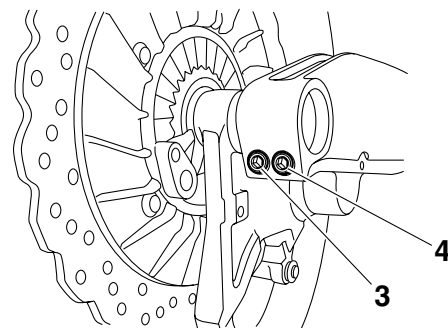
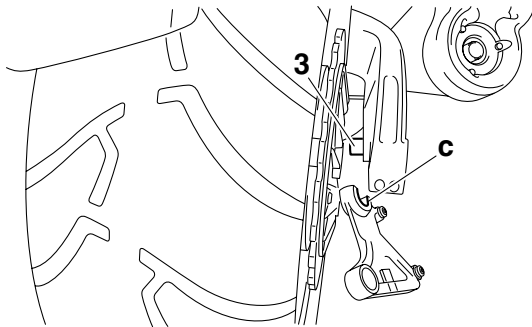

5. Tighten:
- Rear wheel axle
 - Rear wheel axle pinch bolts

	<p>Rear wheel axle 98 Nm (9.8 m·kgf, 71 ft·lbf) Rear wheel axle pinch bolt 16 Nm (1.6 m·kgf, 11 ft·lbf)</p>
---	--



6. Install:
- Brake pad supports
 - Brake pad insulator (onto the left brake pad)
 - Brake pad shims (onto the brake pads)
 - Brake pads
 - Brake caliper retaining bolts
 - Rear brake caliper
- Refer to “REPLACING THE REAR BRAKE PADS” on page 4-47.

	<p>Brake caliper retaining bolt 27 Nm (2.7 m·kgf, 19 ft·lbf)</p>
---	---



a. Tighten the rear wheel axle “1” with the damper rod holder (24 mm) “2”.

	<p>Damper rod holder (24 mm) 90890-01328 YM-01328</p>
---	--

7. Measure:

TIP _____

Measure the distance “a” only if the wheel bearings, wheel sensor rotor, or both were replaced.

- Distance “a” (between the wheel sensor rotor “1” and wheel sensor housing “2”) Out of specification → Reinstall the bearing or replace the wheel sensor rotor.



Distance “a” (between the wheel sensor rotor and wheel sensor housing)
29.2–29.5 mm (1.15–1.16 in)

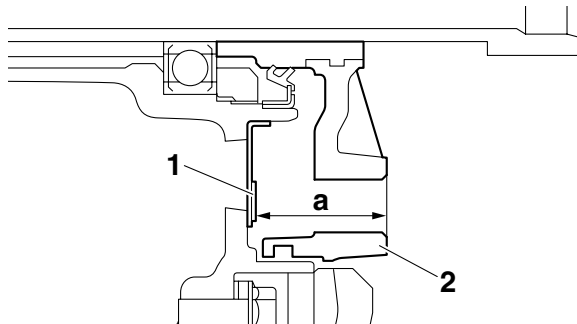

8. Install:

- Rear wheel sensor



Rear wheel sensor bolt
7 Nm (0.7 m·kg, 5.1 ft·lb)

ECA2S31021

NOTICE

To route the rear wheel sensor lead, refer to “CABLE ROUTING” on page 2-47.

TIP

When installing the rear wheel sensor, check the rear wheel sensor lead for twists and the sensor electrode for foreign materials.

9. Check:

- Rear wheel sensor installation
Check if the wheel sensor housing is installed properly.

EAS22210

FRONT BRAKE

Removing the front brake pads

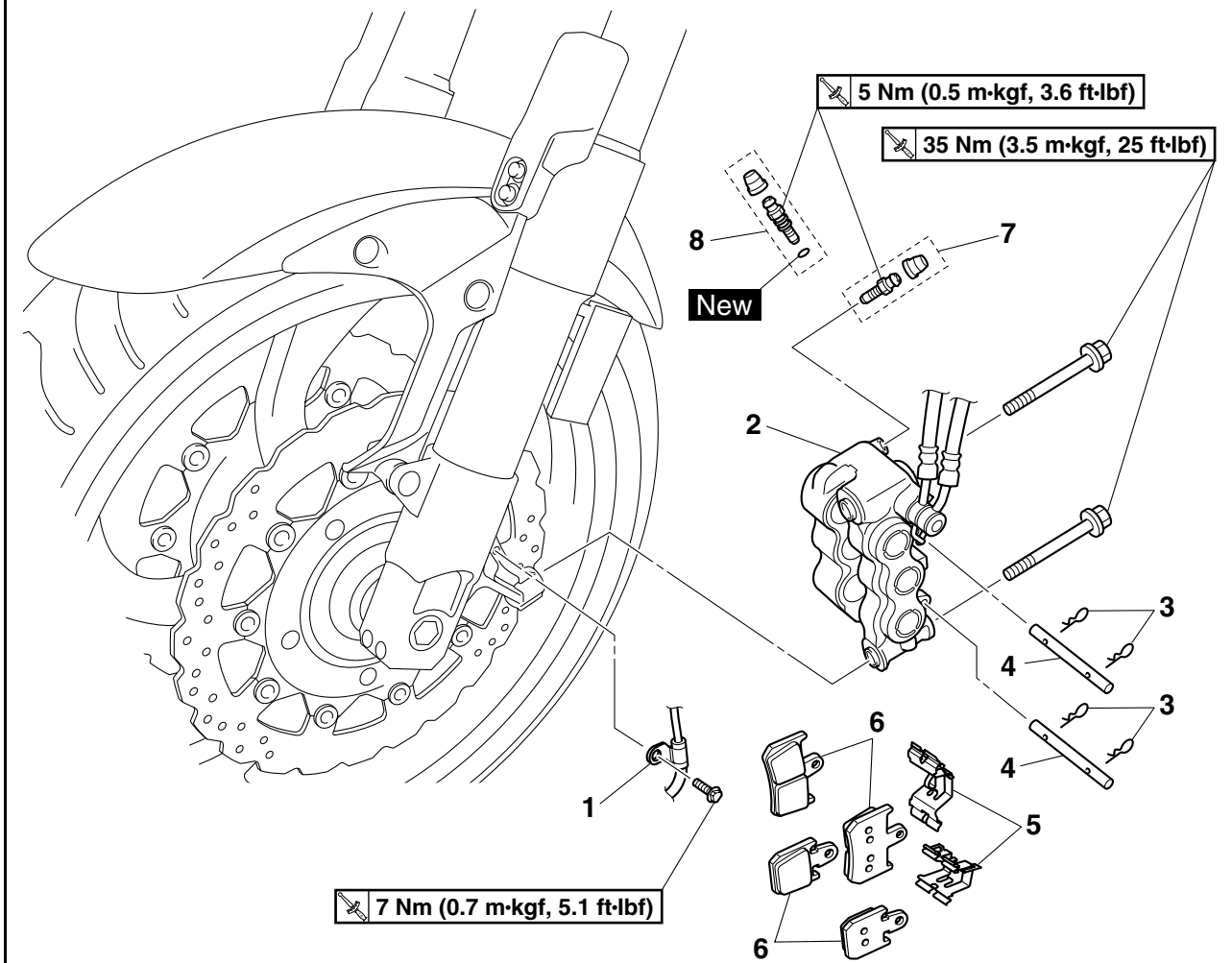

Order	Job/Parts to remove	Q'ty	Remarks
			The following procedure applies to both of the front brake calipers.
1	Front wheel sensor lead holder	1	Left side only.
2	Front brake caliper	1	
3	Brake pad clip	4	
4	Brake pad pin	2	
5	Brake pad spring	2	
6	Front brake pad	4	
7	Bleed screw	1	Left brake caliper side.
8	Bleed screw	1	Right brake caliper side.
			For installation, reverse the removal procedure.

Removing the front brake master cylinder

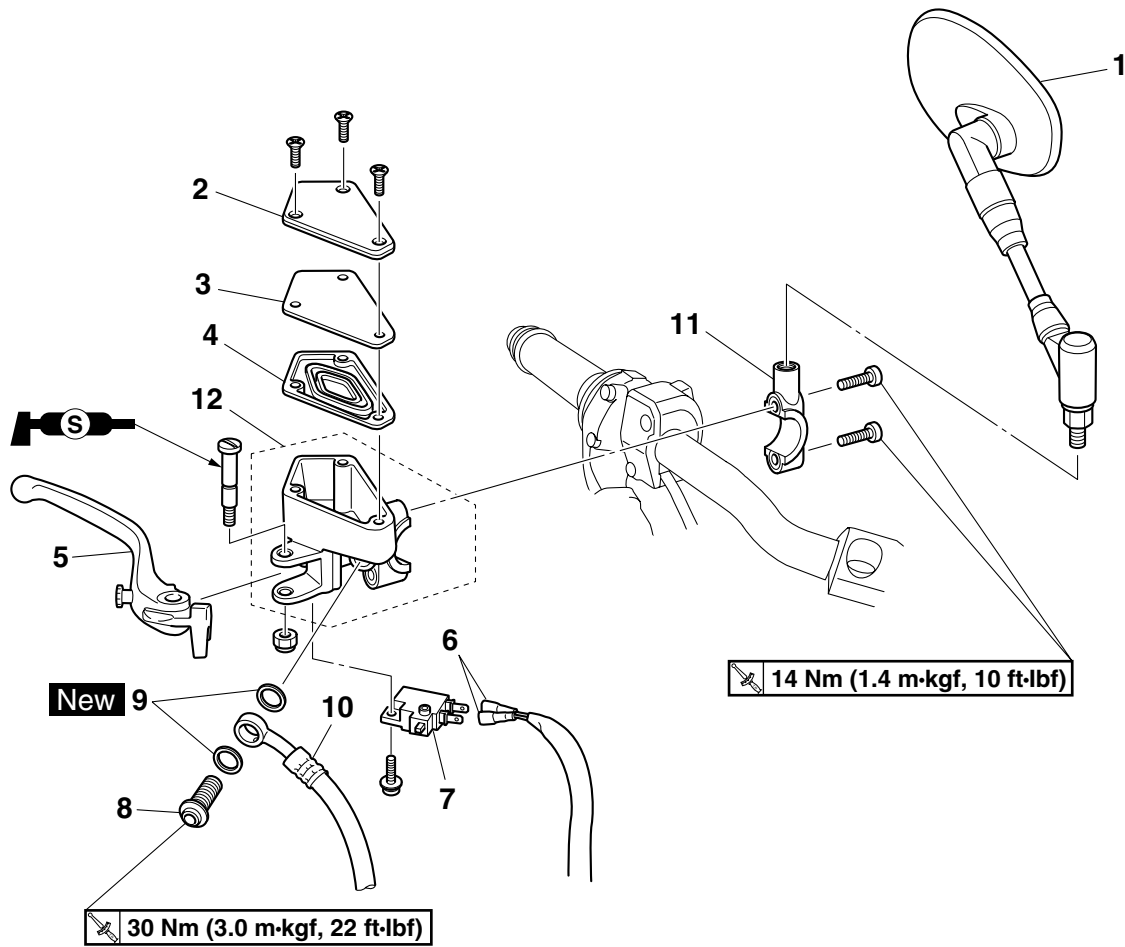

Order	Job/Parts to remove	Q'ty	Remarks
	Brake fluid		Drain. Refer to "BLEEDING THE HYDRAULIC BRAKE SYSTEM (ABS)" on page 3-24.
1	Right rearview mirror	1	
2	Brake master cylinder reservoir cap	1	
3	Brake master cylinder reservoir diaphragm holder	1	
4	Brake master cylinder reservoir diaphragm	1	
5	Brake lever	1	
6	Front brake light switch connector	2	Disconnect.
7	Front brake light switch	1	
8	Brake hose union bolt	1	
9	Brake hose gasket	2	
10	Brake hose (front brake master cylinder to hydraulic unit)	1	
11	Front brake master cylinder holder	1	
12	Front brake master cylinder	1	
			For installation, reverse the removal procedure.

FRONT BRAKE

Disassembling the front brake master cylinder

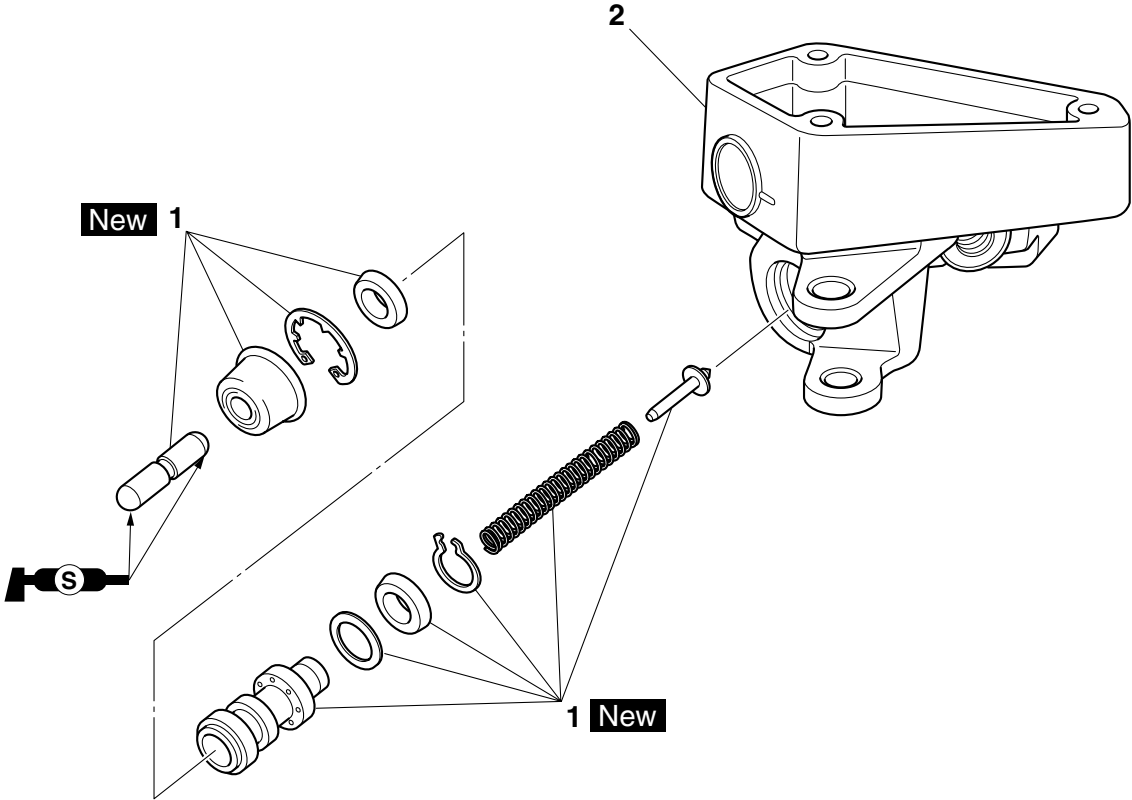

Order	Job/Parts to remove	Q'ty	Remarks
1	Brake master cylinder kit	1	
2	Brake master cylinder body	1	
			For assembly, reverse the disassembly procedure.

FRONT BRAKE

Removing the front brake calipers

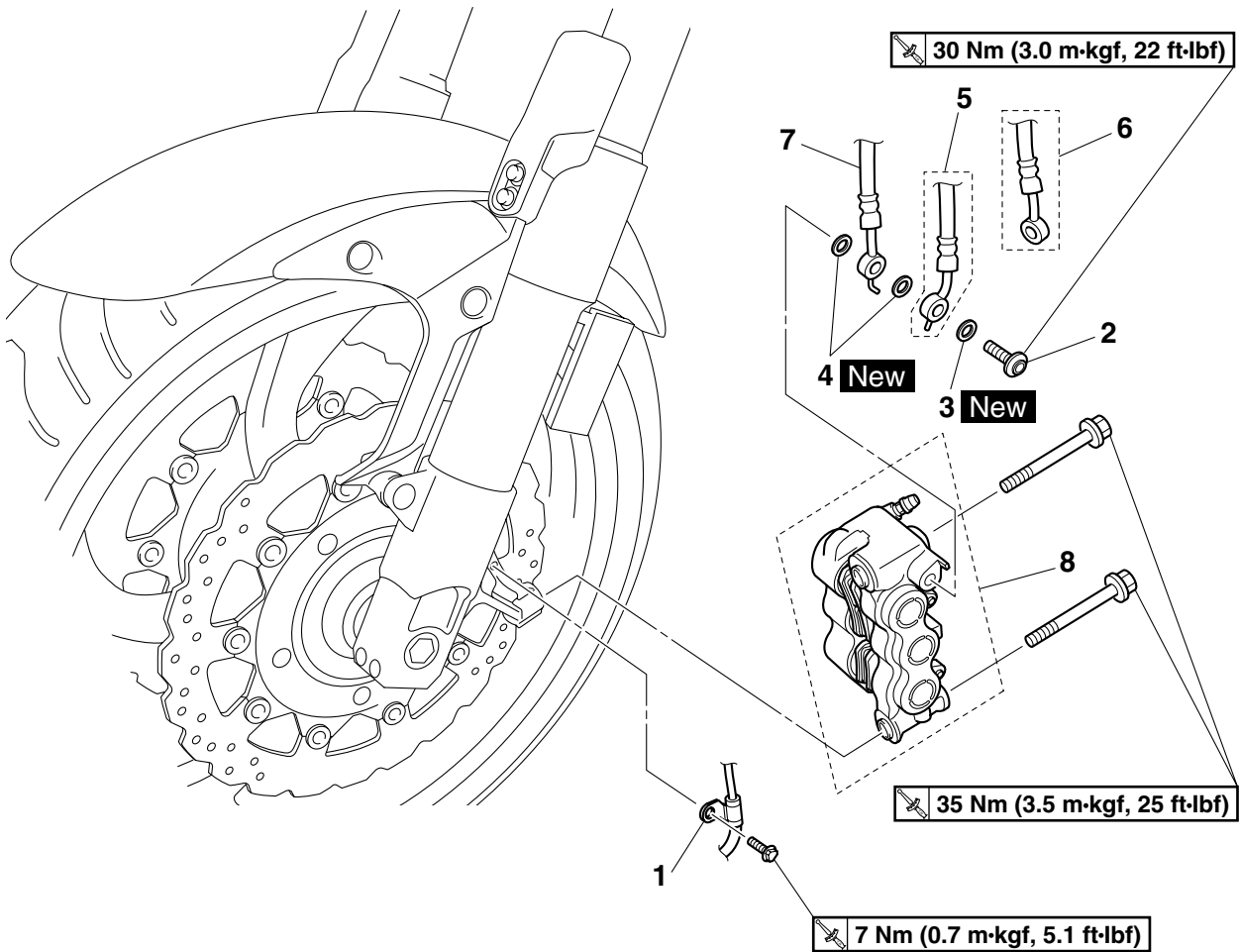

Order	Job/Parts to remove	Q'ty	Remarks
			The following procedure applies to both of the front brake calipers.
	Brake fluid		Drain. Refer to "BLEEDING THE HYDRAULIC BRAKE SYSTEM (ABS)" on page 3-24.
1	Front wheel sensor lead holder	1	Left side only.
2	Brake hose union bolt	1	
3	Brake hose gasket	1	Left side only.
4	Brake hose gasket	2	
5	Brake hose (left front brake caliper to right front brake caliper)	1	Left brake caliper side.
6	Brake hose (left front brake caliper to right front brake caliper)	1	Right brake caliper side.
7	Brake hose (hydraulic unit to left front brake caliper)	1	Left side only.
8	Front brake caliper	1	
			For installation, reverse the removal procedure.

FRONT BRAKE

Disassembling the front brake calipers

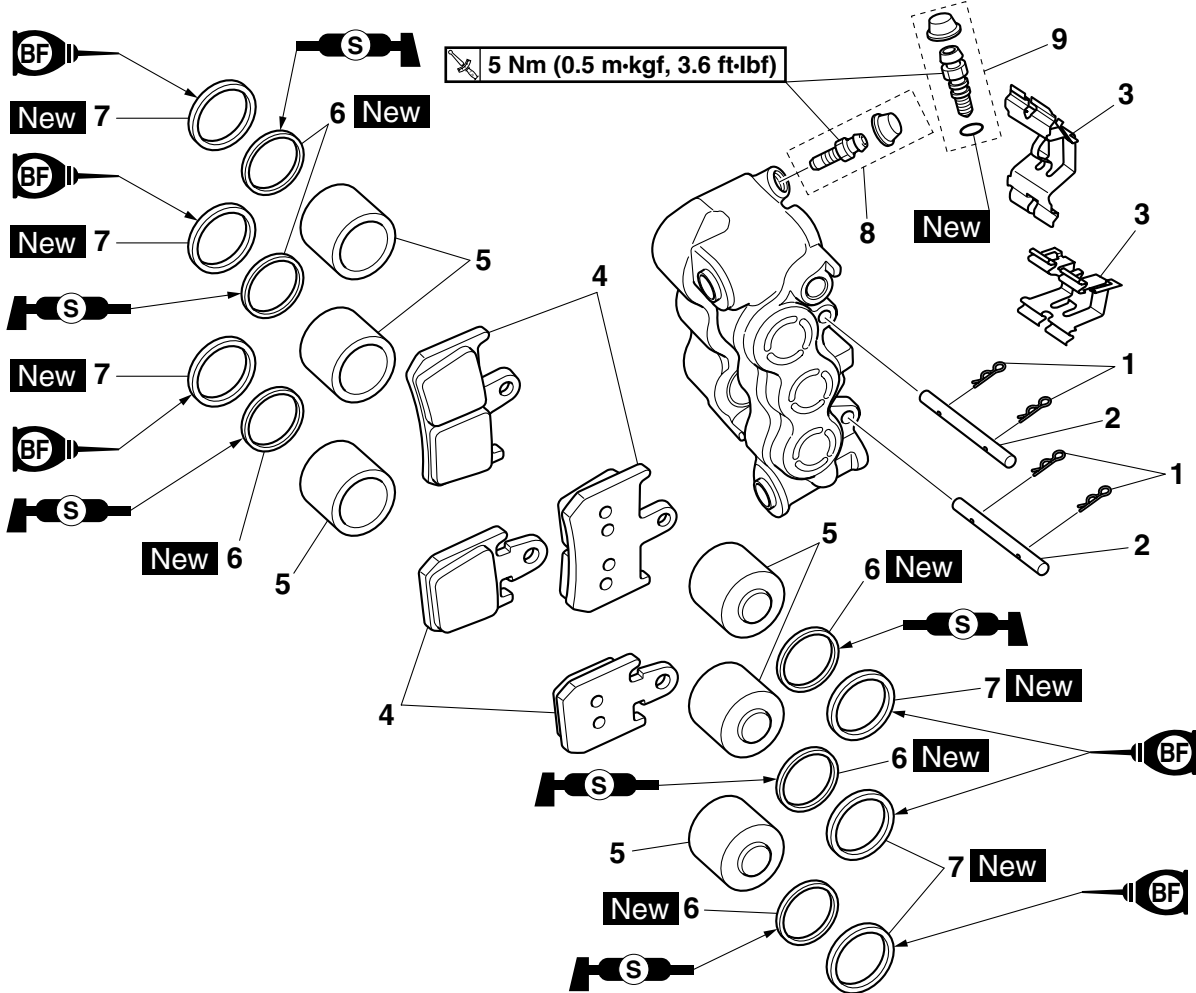

Order	Job/Parts to remove	Q'ty	Remarks
			The following procedure applies to both of the front brake calipers.
1	Brake pad clip	4	
2	Brake pad pin	2	
3	Brake pad spring	2	
4	Front brake pad	4	
5	Brake caliper piston	6	
6	Brake caliper piston dust seal	6	
7	Brake caliper piston seal	6	
8	Bleed screw	1	Left brake caliper side.
9	Bleed screw	1	Right brake caliper side.
			For assembly, reverse the disassembly procedure.

EAS22220

INTRODUCTION

EWA14100

WARNING

Disc brake components rarely require disassembly. Therefore, always follow these preventive measures:

- Never disassemble brake components unless absolutely necessary.
- If any connection on the hydraulic brake system is disconnected, the entire brake system must be disassembled, drained, cleaned, properly filled, and bled after reassembly.
- Never use solvents on internal brake components.
- Use only clean or new brake fluid for cleaning brake components.
- Brake fluid may damage painted surfaces and plastic parts. Therefore, always clean up any spilt brake fluid immediately.
- Avoid brake fluid coming into contact with the eyes as it can cause serious injury.

FIRST AID FOR BRAKE FLUID ENTERING THE EYES:

- Flush with water for 15 minutes and get immediate medical attention.

EAS22240

CHECKING THE FRONT BRAKE DISCS

The following procedure applies to both brake discs.

1. Remove:
 - Front wheel
Refer to "FRONT WHEEL" on page 4-12.
2. Check:
 - Brake disc
Damage/galling → Replace.
3. Measure:
 - Brake disc deflection
Out of specification → Correct the brake disc deflection or replace the brake disc.

	Brake disc deflection limit 0.10 mm (0.0039 in)
---	---

- a. Place the vehicle on a suitable stand so that the front wheel is elevated.
- b. Before measuring the front brake disc deflection, turn the handlebar to the left or right to ensure that the front wheel is stationary.
- c. Remove the brake caliper.
- d. Hold the dial gauge at a right angle against the brake disc surface.

- e. Measure the deflection 1.5 mm (0.06 in) below the edge of the brake disc.

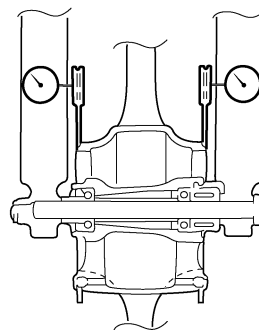

4. Measure:
 - Brake disc thickness
Measure the brake disc thickness at a few different locations.
Out of specification → Replace.

	Brake disc thickness limit 5.0 mm (0.20 in)
---	---

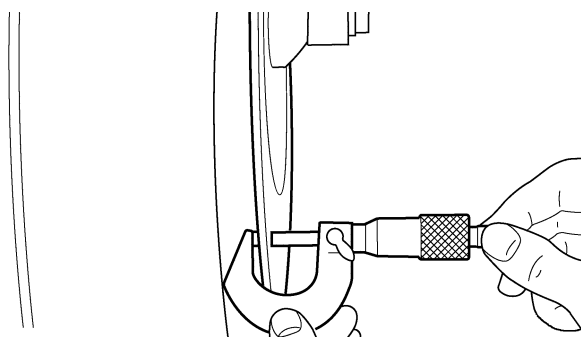

5. Adjust:
 - Brake disc deflection



- a. Remove the brake disc.
- b. Rotate the brake disc by one bolt hole.
- c. Install the brake disc.

	Brake disc bolt 18 Nm (1.8 m·kgf, 13 ft·lbf) LOCTITE®
---	--

TIP

Tighten the brake disc bolts in stages and in a crisscross pattern.

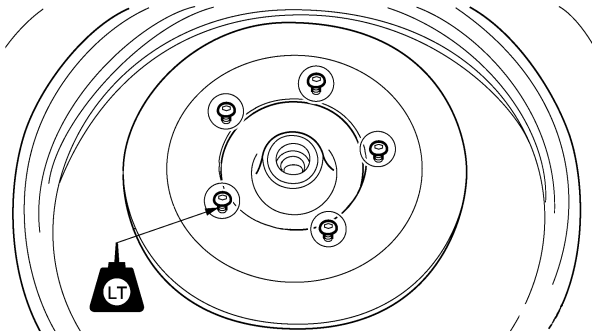

- d. Measure the brake disc deflection.
- e. If out of specification, repeat the adjustment steps until the brake disc deflection is within specification.
- f. If the brake disc deflection cannot be brought within specification, replace the brake disc.



6. Install:
 - Front wheel
 Refer to "FRONT WHEEL" on page 4-12.

EAS22260

REPLACING THE FRONT BRAKE PADS

The following procedure applies to both brake calipers.

TIP

When replacing the brake pads, it is not necessary to disconnect the brake hose or disassemble the brake caliper.

1. Measure:
 - Brake pad wear limit "a"
 Out of specification → Replace the brake pads as a set.



Brake pad lining thickness (inner)
 4.5 mm (0.18 in)
Limit
 0.8 mm (0.03 in)
Brake pad lining thickness (outer)
 4.5 mm (0.18 in)
Limit
 0.8 mm (0.03 in)

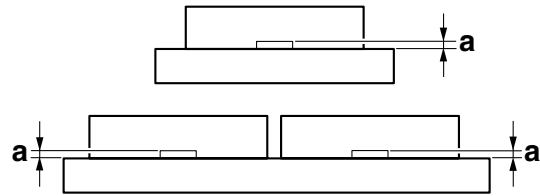

2. Install:
 - Brake pads
 - Brake pad springs

TIP

Always install new brake pads and new brake pad springs as a set.



- a. Connect a clear plastic hose "1" tightly to the bleed screw "2". Put the other end of the hose into an open container.
- b. Loosen the bleed screw and push the brake caliper pistons into the brake caliper with your finger.

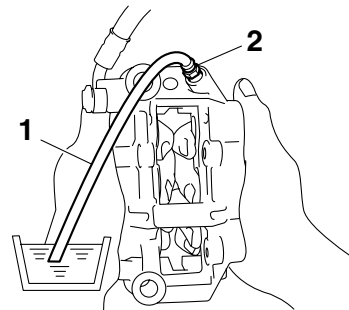

- c. Tighten the bleed screw.



Front brake caliper bleed screw
 5 Nm (0.5 m·kgf, 3.6 ft·lbf)

- d. Install the brake pads and brake pad springs.

TIP

The arrow mark "a" on the brake pad springs must point in the direction of disc rotation.

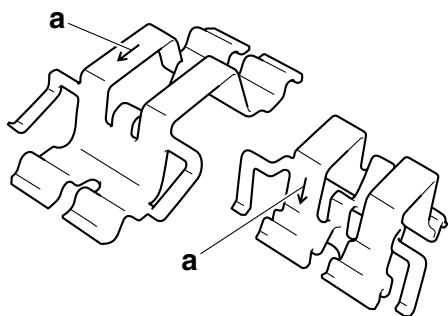

3. Install:

- Brake caliper



Front brake caliper bolt
35 Nm (3.5 m·kgf, 25 ft·lbf)

4. Check:

- Brake fluid level
 Below the minimum level mark "a" → Add the recommended brake fluid to the proper level. Refer to "CHECKING THE BRAKE FLUID LEVEL" on page 3-22.

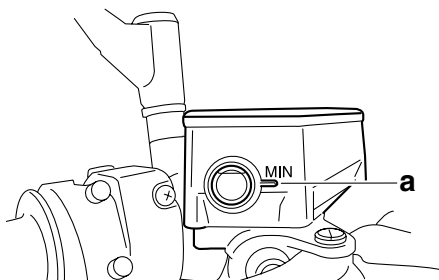

5. Check:

- Brake lever operation
 Soft or spongy feeling → Bleed the brake system. Refer to "BLEEDING THE HYDRAULIC BRAKE SYSTEM (ABS)" on page 3-24.

EAS22300

REMOVING THE FRONT BRAKE CALIPERS

The following procedure applies to both of the brake calipers.

TIP

Before removing the brake caliper, drain the brake fluid from the entire brake system.

1. Remove:

- Front wheel sensor lead holder
- Brake hose union bolt
- Brake hose gaskets
- Brake hose (left front brake caliper to right front brake caliper)

- Brake hose (hydraulic unit to left front brake caliper)

TIP

Put the end of the brake hoses into a container and pump out the brake fluid carefully.

EAS22350

DISASSEMBLING THE FRONT BRAKE CALIPERS

The following procedure applies to both of the brake calipers.

1. Remove:

- Brake caliper pistons "1"
- Brake caliper piston dust seals "2"
- Brake caliper piston seals "3"

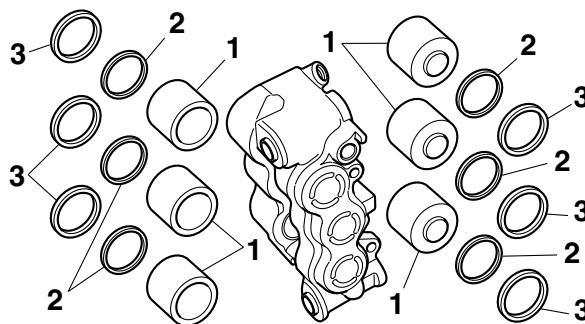

- a. Blow compressed air into the brake hose joint opening "a" to force out the piston from the brake caliper.

EWA13560

! WARNING

- Cover the brake caliper pistons with a rag. Be careful not to get injured when the pistons are expelled from the brake caliper.
- Never try to pry out the brake caliper pistons.

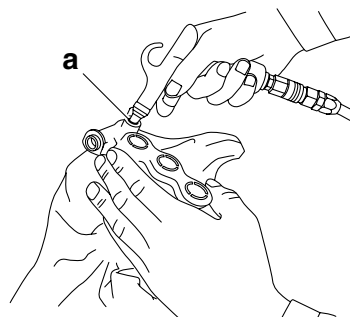

- b. Remove the brake caliper piston dust seals and brake caliper piston seals.

EAS22390

CHECKING THE FRONT BRAKE CALIPERS

Recommended brake component replacement schedule	
Brake pads	If necessary
Piston seals	Every two years
Piston dust seals	Every two years
Brake hoses	Every four years
Brake fluid	Every two years and whenever the brake is disassembled

1. Check:

- Brake caliper pistons “1”
Rust/scratches/wear → Replace the brake caliper pistons.
- Brake caliper cylinders “2”
Scratches/wear → Replace the brake caliper assembly.
- Brake caliper body “3”
Cracks/damage → Replace the brake caliper assembly.
- Brake fluid delivery passages (brake caliper body)
Obstruction → Blow out with compressed air.

EWA2S31006

WARNING

Whenever a brake caliper is disassembled, replace the brake caliper piston dust seals and brake caliper piston seals.

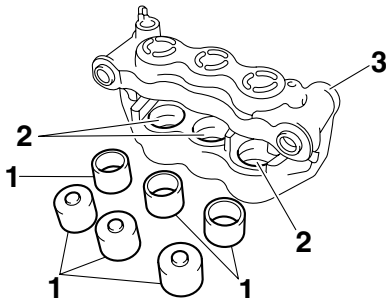

EAS22410

ASSEMBLING THE FRONT BRAKE CALIPERS

EWA2S31007

WARNING

- Before installation, all internal brake components should be cleaned and lubricated with clean or new brake fluid.
- Never use solvents on internal brake components as they will cause the brake caliper piston dust seals and brake caliper piston seals to swell and distort.

- Whenever a brake caliper is disassembled, replace the brake caliper piston dust seals and brake caliper piston seals.



Recommended fluid
DOT 4

EAS22440

INSTALLING THE FRONT BRAKE CALIPERS

The following procedure applies to both of the brake calipers.

1. Install:

- Front brake caliper (temporarily)
- Brake hose gaskets **New**
- Brake hose (hydraulic unit to left front brake caliper) “1”
- Brake hose (left front brake caliper to right front brake caliper) “2”
- Brake hose union bolt “3”

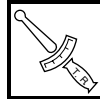

Brake hose union bolt
30 Nm (3.0 m·kgf, 22 ft·lbf)

EWA13530

WARNING

Proper brake hose routing is essential to insure safe vehicle operation. Refer to “CABLE ROUTING” on page 2-47.

ECA2S31059

NOTICE

Left side

- When installing the brake hose “1” onto the brake caliper, make sure the brake pipe “a” touches the projection “b” on the brake caliper.
- When installing the brake hose “2” onto the brake caliper, make sure the projection “c” on the brake hose “2” touches the projection “d” on the brake hose “1”.

Right side

- When installing the brake hose “2” onto the brake caliper, make sure the brake pipe “e” touches the projection “f” on the brake caliper.

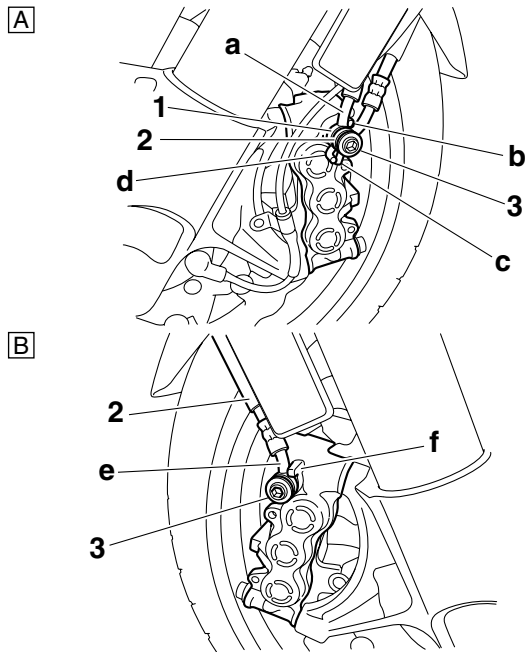

A. Left side
B. Right side

2. Remove:
 - Front brake caliper
3. Install:
 - Brake pads
 - Brake pad springs
 - Brake pad pins
 - Brake pad clips
 - Front brake caliper
 - Front wheel sensor lead holder

Refer to “REPLACING THE FRONT BRAKE PADS” on page 4-35.



Front brake caliper bolt
35 Nm (3.5 m·kgf, 25 ft·lbf)
Front wheel sensor lead holder bolt
7 Nm (0.7 m·kgf, 5.1 ft·lbf)

4. Fill:
 - Brake master cylinder reservoir (with the specified amount of the recommended brake fluid)



Recommended fluid
DOT 4

EWA13090

WARNING

- Use only the designated brake fluid. Other brake fluids may cause the rubber seals to deteriorate, causing leakage and poor brake performance.

- Refill with the same type of brake fluid that is already in the system. Mixing brake fluids may result in a harmful chemical reaction, leading to poor brake performance.
- When refilling, be careful that water does not enter the brake fluid reservoir. Water will significantly lower the boiling point of the brake fluid and could cause vapor lock.

ECA13540

NOTICE

Brake fluid may damage painted surfaces and plastic parts. Therefore, always clean up any spilt brake fluid immediately.

5. Bleed:
 - Brake system

Refer to “BLEEDING THE HYDRAULIC BRAKE SYSTEM (ABS)” on page 3-24.
6. Check:
 - Brake fluid level

Below the minimum level mark “a” → Add the recommended brake fluid to the proper level. Refer to “CHECKING THE BRAKE FLUID LEVEL” on page 3-22.

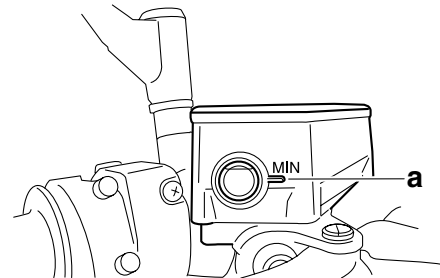

7. Check:
 - Brake lever operation

Soft or spongy feeling → Bleed the brake system. Refer to “BLEEDING THE HYDRAULIC BRAKE SYSTEM (ABS)” on page 3-24.

EAS22490

REMOVING THE FRONT BRAKE MASTER CYLINDER

TIP

Before removing the front brake master cylinder, drain the brake fluid from the entire brake system.

1. Remove:
 - Brake hose union bolt “1”
 - Brake hose gaskets “2”
 - Brake hoses (front brake master cylinder to hydraulic unit) “3”

TIP

To collect any remaining brake fluid, place a container under the master cylinder and the end of the brake hose.

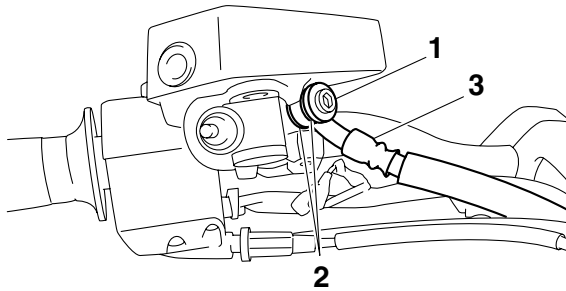

EAS22500

CHECKING THE FRONT BRAKE MASTER CYLINDER

1. Check:
 - Brake master cylinder
Damage/scratches/wear → Replace.
 - Brake fluid delivery passages (brake master cylinder body)
Obstruction → Blow out with compressed air.
2. Check:
 - Brake master cylinder kit
Damage/scratches/wear → Replace.
3. Check:
 - Brake master cylinder reservoir
Cracks/damage → Replace.
 - Brake master cylinder reservoir diaphragm
Damage/wear → Replace.
4. Check:
 - Brake hose
Cracks/damage/wear → Replace.

EAS22520

ASSEMBLING THE FRONT BRAKE MASTER CYLINDER

EWA13520

WARNING

- Before installation, all internal brake components should be cleaned and lubricated with clean or new brake fluid.
- Never use solvents on internal brake components.



**Recommended fluid
DOT 4**

EAS22530

INSTALLING THE FRONT BRAKE MASTER CYLINDER

1. Install:
 - Brake master cylinder “1”
 - Brake master cylinder holder “2”



**Brake master cylinder holder bolt
14 Nm (1.4 m·kgf, 10 ft·lbf)**

TIP

- Align the mating surfaces of the brake master cylinder holder with the punch mark “a” on the handlebar.
- First, tighten the upper bolt, then the lower bolt.

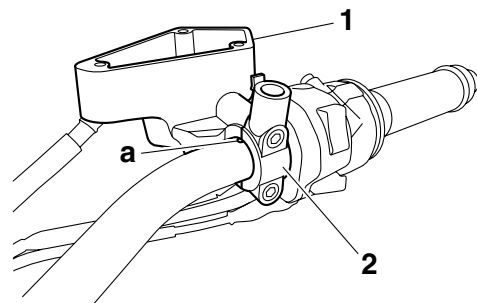

2. Install:

- Brake hose gaskets **New**
- Brake hose (front brake master cylinder to hydraulic unit) “1”
- Brake hose union bolt “2”



**Brake hose union bolt (front
brake master cylinder)
30 Nm (3.0 m·kgf, 22 ft·lbf)**

EWA13530

WARNING

Proper brake hose routing is essential to insure safe vehicle operation. Refer to “CABLE ROUTING” on page 2-47.

TIP

- Install the brake hose at 40–50° angle “a” to the front brake master cylinder as shown in the illustration.
- While holding the brake hose, tighten the union bolt.
- Turn the handlebar to the left and right to make sure the brake hose does not touch other parts (e.g., wire harness, cables, leads). Correct if necessary.

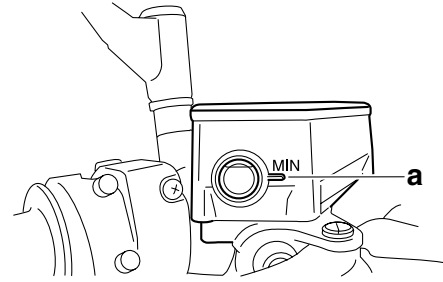
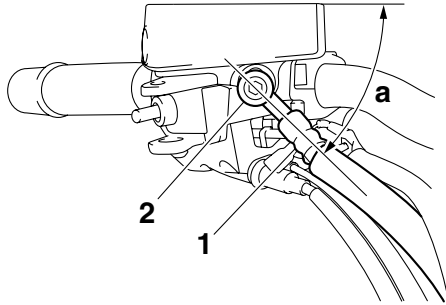

3. Fill:

- Brake master cylinder reservoir (with the specified amount of the recommended brake fluid)



EWA13540

WARNING

- Use only the designated brake fluid. Other brake fluids may cause the rubber seals to deteriorate, causing leakage and poor brake performance.
- Refill with the same type of brake fluid that is already in the system. Mixing brake fluids may result in a harmful chemical reaction, leading to poor brake performance.
- When refilling, be careful that water does not enter the brake master cylinder reservoir. Water will significantly lower the boiling point of the brake fluid and could cause vapor lock.

ECA13540

NOTICE

Brake fluid may damage painted surfaces and plastic parts. Therefore, always clean up any spilt brake fluid immediately.

4. Bleed:

- Brake system
Refer to "BLEEDING THE HYDRAULIC BRAKE SYSTEM (ABS)" on page 3-24.

5. Check:

- Brake fluid level
Below the minimum level mark "a" → Add the recommended brake fluid to the proper level. Refer to "CHECKING THE BRAKE FLUID LEVEL" on page 3-22.

6. Check:

- Brake lever operation
Soft or spongy feeling → Bleed the brake system.
Refer to "BLEEDING THE HYDRAULIC BRAKE SYSTEM (ABS)" on page 3-24.

EAS22550

REAR BRAKE

Removing the rear brake pads

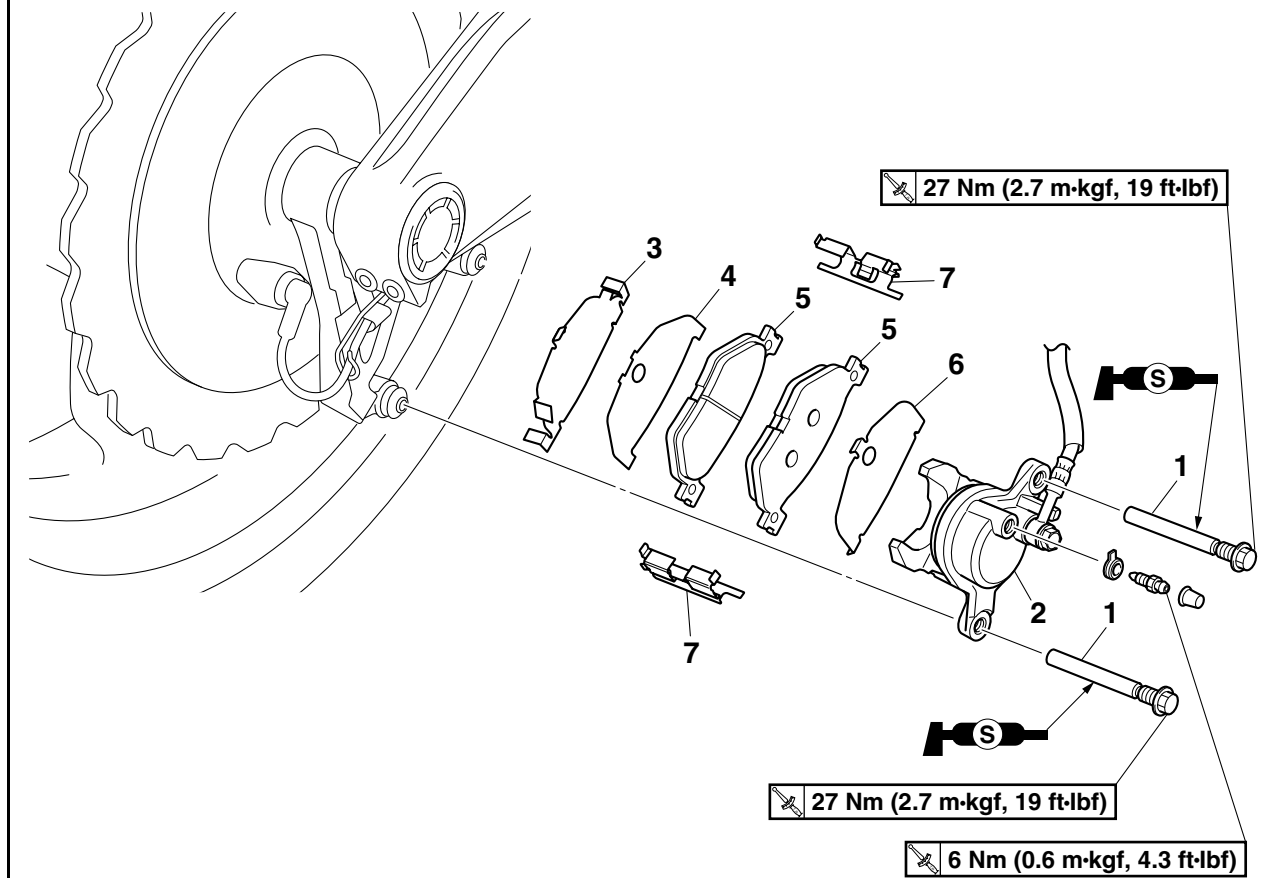

Order	Job/Parts to remove	Q'ty	Remarks
1	Rear brake caliper retaining bolt	2	
2	Rear brake caliper	1	
3	Brake pad shim	1	
4	Brake pad insulator	1	Left side only.
5	Rear brake pad	2	
6	Brake pad shim	1	
7	Brake pad support	2	
			For installation, reverse the removal procedure.

Removing the rear brake master cylinder

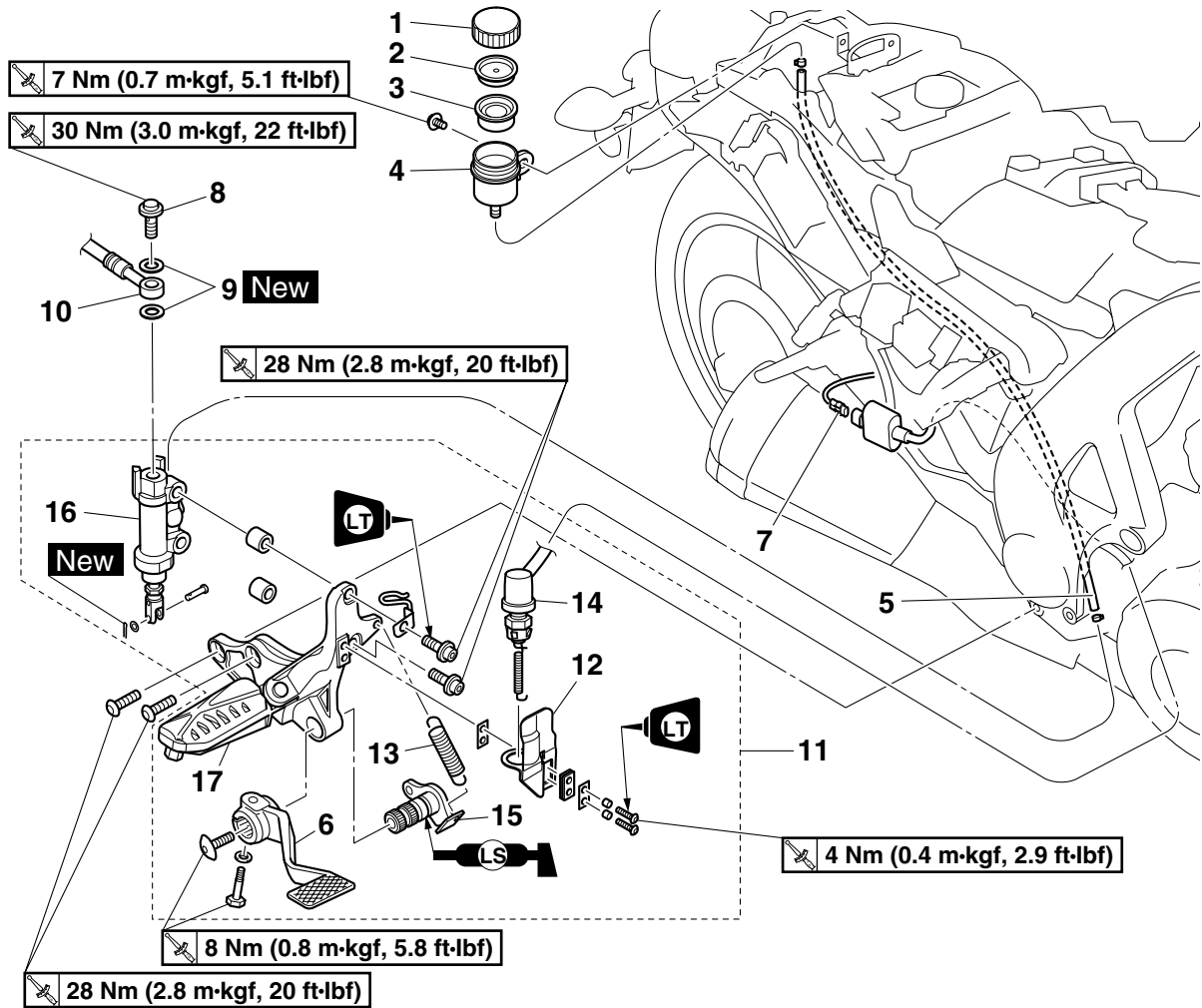

Order	Job/Parts to remove	Q'ty	Remarks
	Right side cover/Rear fender		Refer to "GENERAL CHASSIS" on page 4-1.
	Brake fluid		Drain. Refer to "BLEEDING THE HYDRAULIC BRAKE SYSTEM (ABS)" on page 3-24.
1	Brake fluid reservoir cap	1	
2	Brake fluid reservoir diaphragm holder	1	
3	Brake fluid reservoir diaphragm	1	
4	Brake fluid reservoir	1	
5	Brake fluid reservoir hose	1	
6	Brake pedal	1	
7	Rear brake light switch coupler	1	Disconnect.
8	Brake hose union bolt	1	
9	Brake hose gasket	2	
10	Brake hose (rear brake master cylinder to hydraulic unit)	1	
11	Right rider footrest assembly	1	
12	Rear brake light switch bracket	1	
13	Brake pedal pivot shaft spring	1	

Removing the rear brake master cylinder

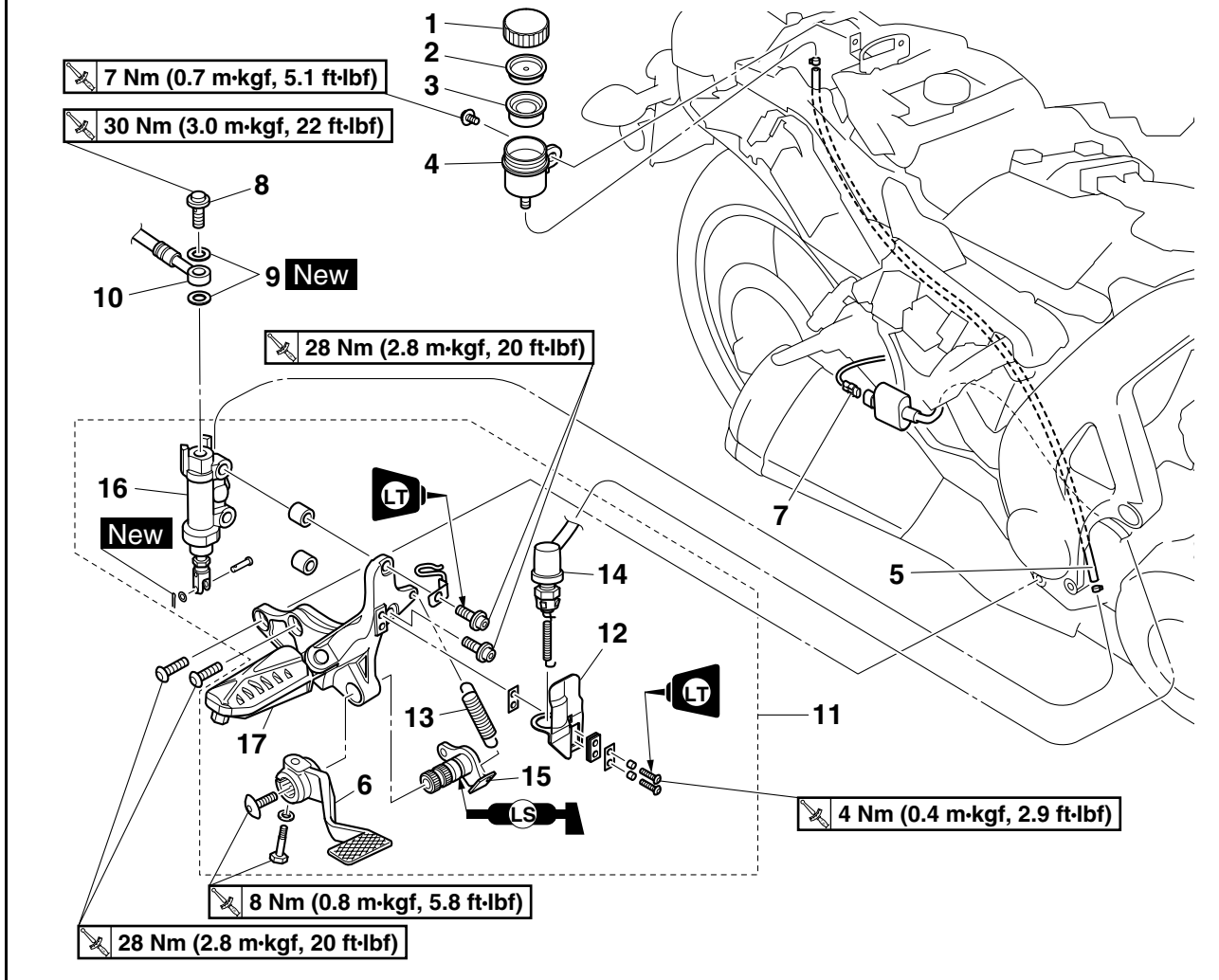

Order	Job/Parts to remove	Q'ty	Remarks
14	Rear brake light switch	1	
15	Brake pedal pivot shaft	1	
16	Rear brake master cylinder	1	
17	Right rider footrest	1	
			For installation, reverse the removal procedure.

Disassembling the rear brake master cylinder

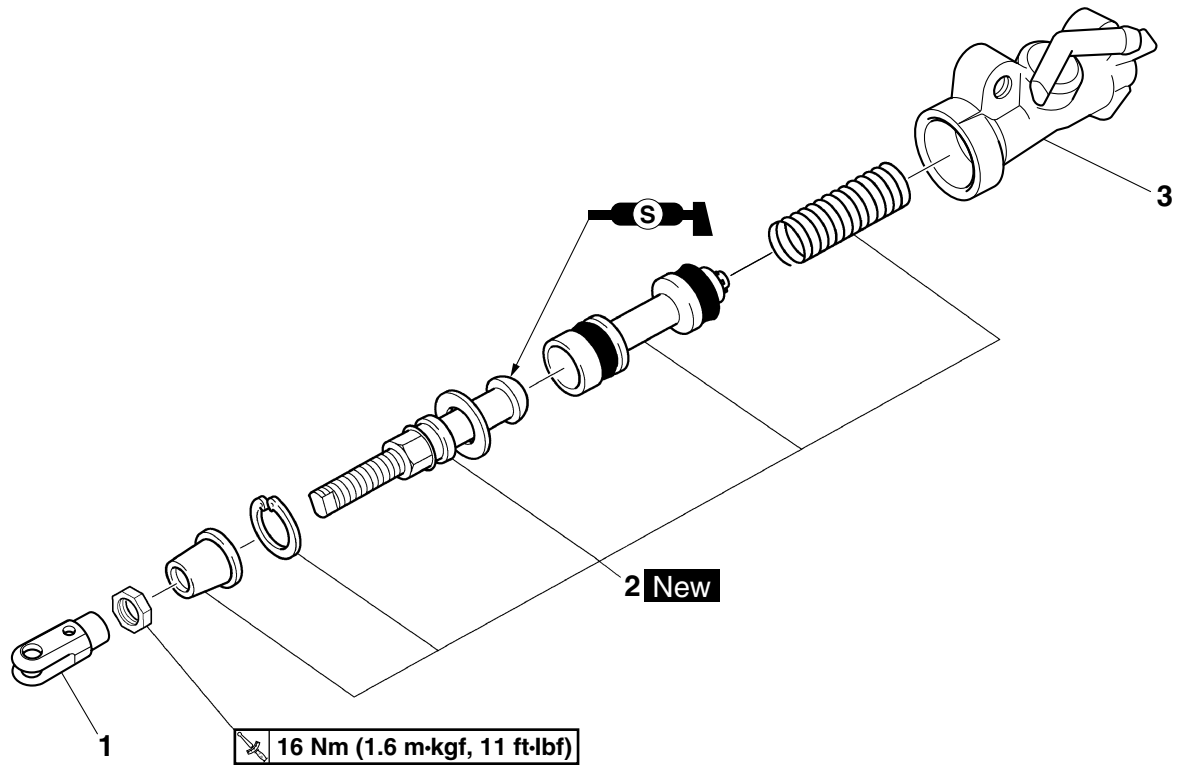

Order	Job/Parts to remove	Q'ty	Remarks
1	Rear brake master cylinder joint	1	
2	Brake master cylinder kit	1	
3	Brake master cylinder body	1	
			For assembly, reverse the disassembly procedure.

Removing the rear brake caliper

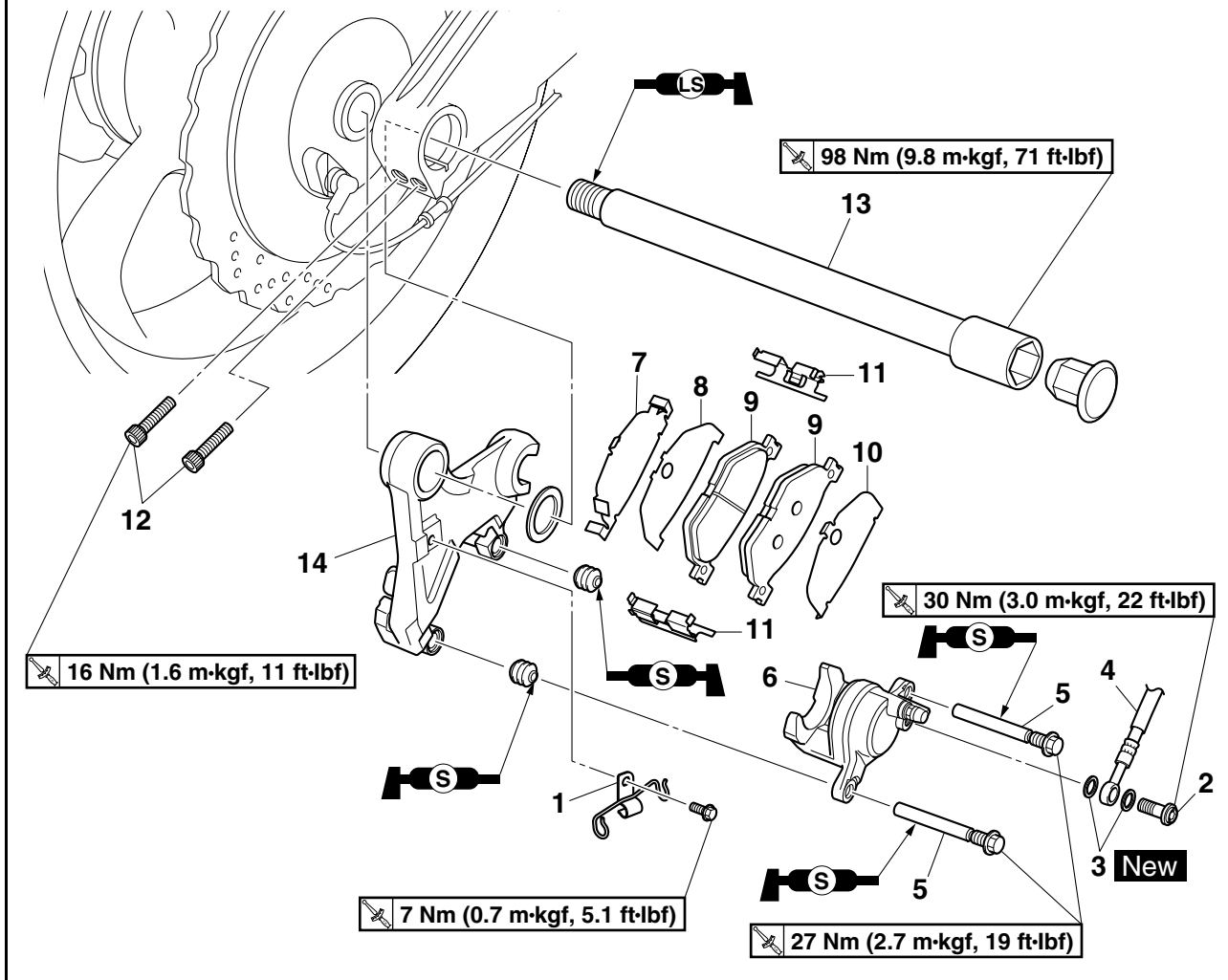

Order	Job/Parts to remove	Q'ty	Remarks
	Brake fluid		Drain. Refer to "BLEEDING THE HYDRAULIC BRAKE SYSTEM (ABS)" on page 3-24.
1	Rear wheel sensor lead holder	1	
2	Brake hose union bolt	1	
3	Brake hose gasket	2	
4	Brake hose (hydraulic unit to rear brake caliper)	1	
5	Rear brake caliper retaining bolt	2	
6	Rear brake caliper	1	
7	Brake pad shim	1	
8	Brake pad insulator	1	Left side only.
9	Rear brake pad	2	
10	Brake pad shim	1	
11	Brake pad support	2	
12	Rear wheel axle pinch bolt	2	Loosen.
13	Rear wheel axle	1	
14	Rear brake caliper bracket	1	
			For installation, reverse the removal procedure.

Disassembling the rear brake caliper

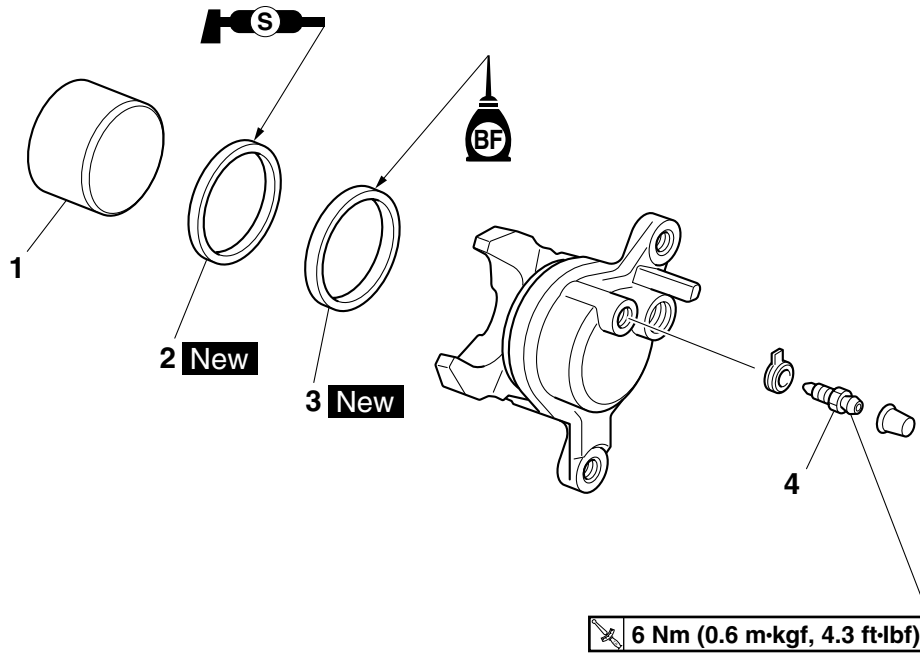

Order	Job/Parts to remove	Q'ty	Remarks
1	Brake caliper piston	1	
2	Brake caliper piston dust seal	1	
3	Brake caliper piston seal	1	
4	Bleed screw	1	
			For assembly, reverse the disassembly procedure.

EAS22560

INTRODUCTION

EWA14100



WARNING

Disc brake components rarely require disassembly. Therefore, always follow these preventive measures:

- Never disassemble brake components unless absolutely necessary.
- If any connection on the hydraulic brake system is disconnected, the entire brake system must be disassembled, drained, cleaned, properly filled, and bled after reassembly.
- Never use solvents on internal brake components.
- Use only clean or new brake fluid for cleaning brake components.
- Brake fluid may damage painted surfaces and plastic parts. Therefore, always clean up any spilt brake fluid immediately.
- Avoid brake fluid coming into contact with the eyes as it can cause serious injury.

FIRST AID FOR BRAKE FLUID ENTERING THE EYES:

- Flush with water for 15 minutes and get immediate medical attention.

EAS22570

CHECKING THE REAR BRAKE DISC

1. Remove:
 - Rear wheel
Refer to "REAR WHEEL" on page 4-20.
2. Check:
 - Brake disc
Damage/galling → Replace.
3. Measure:
 - Brake disc deflection
Out of specification → Correct the brake disc deflection or replace the brake disc.
Refer to "CHECKING THE FRONT BRAKE DISCS" on page 4-34.



Brake disc deflection limit
0.15 mm (0.0059 in)

4. Measure:
 - Brake disc thickness
Measure the brake disc thickness at a few different locations.
Out of specification → Replace.
Refer to "CHECKING THE FRONT BRAKE DISCS" on page 4-34.



Brake disc thickness limit
5.5 mm (0.22 in)

5. Adjust:
 - Brake disc deflection
Refer to "CHECKING THE FRONT BRAKE DISCS" on page 4-34.

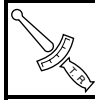

Brake disc bolt
23 Nm (2.3 m·kgf, 17 ft·lbf)
LOCTITE®

6. Install:
 - Rear wheel
Refer to "REAR WHEEL" on page 4-20.

EAS22580

REPLACING THE REAR BRAKE PADS

TIP

When replacing the brake pads, it is not necessary to disconnect the brake hose or disassemble the brake caliper.

1. Measure:
 - Brake pad wear limit "a"
Out of specification → Replace the brake pads as a set.



Brake pad lining thickness (inner)
5.4 mm (0.21 in)
Limit
0.8 mm (0.03 in)
Brake pad lining thickness (outer)
5.4 mm (0.21 in)
Limit
0.8 mm (0.03 in)

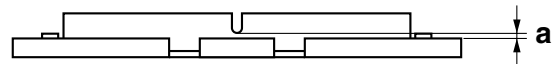

2. Install:
 - Brake pad supports
 - Brake pad insulator (onto the left brake pad)
 - Brake pad shims (onto the brake pads)

- Brake pads

TIP

Always install new brake pads, brake pad shims, brake pad insulator, and brake pad supports as a set.

- Connect a clear plastic hose "1" tightly to the bleed screw "2". Put the other end of the hose into an open container.
- Loosen the bleed screw and push the brake caliper pistons into the brake caliper with your finger.

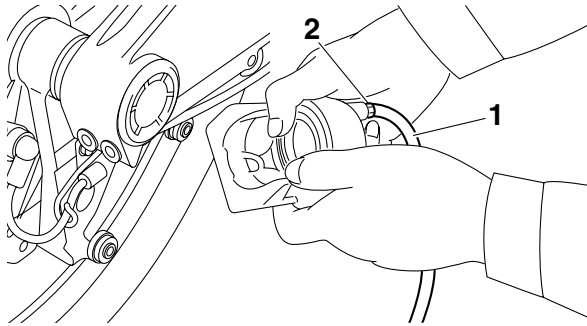

- Tighten the bleed screw.



Bleed screw
6 Nm (0.6 m·kgf, 4.3 ft·lbf)

- Install the brake pad supports, brake pad insulator, brake pad shims, and brake pads.

- Lubricate:

- Rear brake caliper retaining bolts

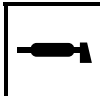

Recommended lubricant
Silicone grease

ECA2S31022

NOTICE

- Do not allow grease to contact the brake pads.
- Remove any excess grease.

- Install:

- Rear brake caliper



Brake caliper retaining bolt
27 Nm (2.7 m·kgf, 19 ft·lbf)

- Check:

- Brake fluid level
Below the minimum level mark "a" → Add the recommended brake fluid to the proper level. Refer to "CHECKING THE BRAKE FLUID LEVEL" on page 3-22.

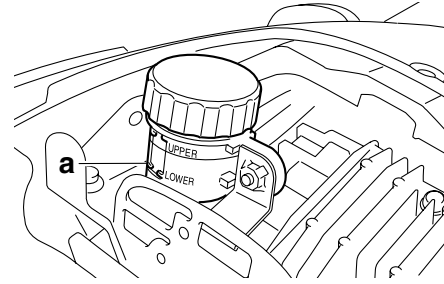

- Check:

- Brake pedal operation
Soft or spongy feeling → Bleed the brake system.
Refer to "BLEEDING THE HYDRAULIC BRAKE SYSTEM (ABS)" on page 3-24.

EAS22590

REMOVING THE REAR BRAKE CALIPER

TIP

Before removing the brake caliper, drain the brake fluid from the entire brake system.

- Remove:

- Brake hose union bolt "1"
- Brake hose gaskets "2"
- Brake hose (hydraulic unit to rear brake caliper) "3"

TIP

Put the end of the brake hose into a container and pump out the brake fluid carefully.

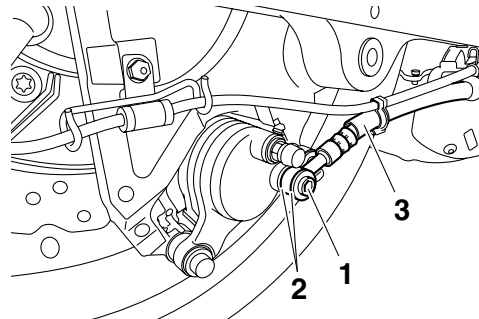

- Remove:

- Rear wheel axle "1"

TIP

Remove the rear wheel axle with the damper rod holder (24 mm) "2".



Damper rod holder (24 mm)
90890-01328
YM-01328

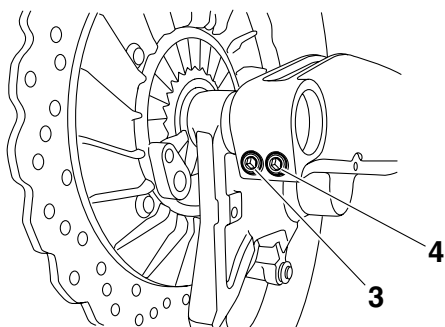

3. Install:

- Brake hose gaskets **New**
- Brake hose (hydraulic unit to rear brake caliper) "1"
- Brake hose union bolt "2"



Brake hose union bolt
30 Nm (3.0 m·kgf, 22 ft·lbf)

EWA13530

WARNING

Proper brake hose routing is essential to insure safe vehicle operation. Refer to "CABLE ROUTING" on page 2-47.

ECA2S31023

NOTICE

When installing the brake hose onto the brake caliper, make sure the brake pipe "a" touches the projection "b" on the brake caliper.

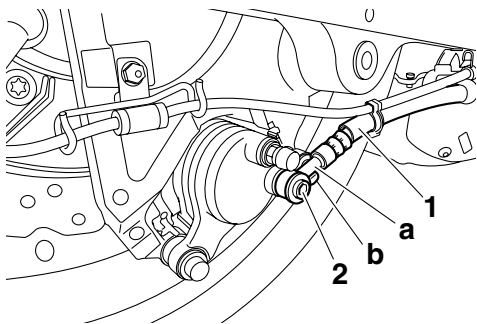

4. Install:

- Brake pad supports
 - Brake pad insulator (onto the left brake pad)
 - Brake pad shims (onto the brake pads)
 - Brake pads
 - Brake caliper retaining bolts
 - Rear brake caliper
- Refer to "REPLACING THE REAR BRAKE PADS" on page 4-47.

- Rear wheel sensor lead holder



Brake caliper retaining bolt
27 Nm (2.7 m·kgf, 19 ft·lbf)
Rear wheel sensor lead holder bolt
7 Nm (0.7 m·kgf, 5.1 ft·lbf)

5. Fill:

- Brake fluid reservoir (with the specified amount of the recommended brake fluid)



Recommended fluid
DOT 4

EWA13090

WARNING

- Use only the designated brake fluid. Other brake fluids may cause the rubber seals to deteriorate, causing leakage and poor brake performance.
- Refill with the same type of brake fluid that is already in the system. Mixing brake fluids may result in a harmful chemical reaction, leading to poor brake performance.
- When refilling, be careful that water does not enter the brake fluid reservoir. Water will significantly lower the boiling point of the brake fluid and could cause vapor lock.

ECA13540

NOTICE

Brake fluid may damage painted surfaces and plastic parts. Therefore, always clean up any spill brake fluid immediately.

6. Bleed:

- Brake system
- Refer to "BLEEDING THE HYDRAULIC BRAKE SYSTEM (ABS)" on page 3-24.

7. Check:

- Brake fluid level
- Below the minimum level mark "a" → Add the recommended brake fluid to the proper level. Refer to "CHECKING THE BRAKE FLUID LEVEL" on page 3-22.

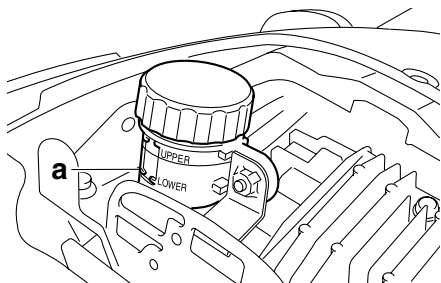

8. Check:
- Brake pedal operation
Soft or spongy feeling → Bleed the brake system.
Refer to “BLEEDING THE HYDRAULIC BRAKE SYSTEM (ABS)” on page 3-24.

EAS22700

REMOVING THE REAR BRAKE MASTER CYLINDER

TIP

Before removing the rear brake master cylinder, drain the brake fluid from the entire brake system.

1. Remove:
- Brake hose union bolt “1”
 - Brake hose gasket “2”
 - Brake hose (rear brake master cylinder to hydraulic unit) “3”

TIP

To collect any remaining brake fluid, place a container under the master cylinder and the end of the brake hose.

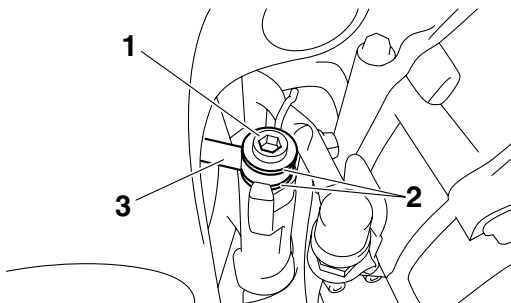

EAS22720

CHECKING THE REAR BRAKE MASTER CYLINDER

1. Check:
- Brake master cylinder
Damage/scratches/wear → Replace.
 - Brake fluid delivery passages (brake master cylinder body)
Obstruction → Blow out with compressed air.

2. Check:
- Brake master cylinder kit
Damage/scratches/wear → Replace.
3. Check:
- Brake fluid reservoir
Cracks/damage → Replace.
 - Brake fluid reservoir diaphragm
Cracks/damage → Replace.
4. Check:
- Brake hoses
Cracks/damage/wear → Replace.

EAS22730

ASSEMBLING THE REAR BRAKE MASTER CYLINDER

EWA13520

WARNING

- Before installation, all internal brake components should be cleaned and lubricated with clean or new brake fluid.
- Never use solvents on internal brake components.



Recommended fluid
DOT 4

1. Install:
- Brake master cylinder kit **New**
 - Rear brake master cylinder joint

TIP

The rear brake master cylinder joint installation length “a” should be 69.8 mm (2.75 in).

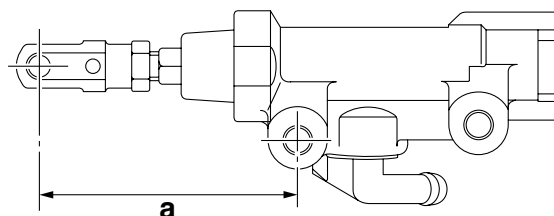

EAS22740

INSTALLING THE REAR BRAKE MASTER CYLINDER

1. Install:
- Rear brake light switch “1”
 - Brake pedal pivot shaft spring

TIP

Install the rear brake light switch spring and brake pedal pivot shaft spring “2” as shown in the illustration.

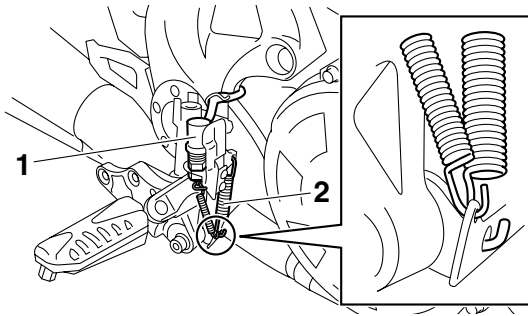

2. Install:

- Brake hose gaskets **New**
- Brake hose (rear brake master cylinder to hydraulic unit) "1"
- Brake hose union bolt "2"



Brake hose union bolt
30 Nm (3.0 m·kgf, 22 ft·lbf)

EWA13530

WARNING

Proper brake hose routing is essential to insure safe vehicle operation. Refer to "CABLE ROUTING" on page 2-47.

ECA14160

NOTICE

When installing the brake hose onto the brake master cylinder, make sure the brake pipe touches the projection "a" as shown.

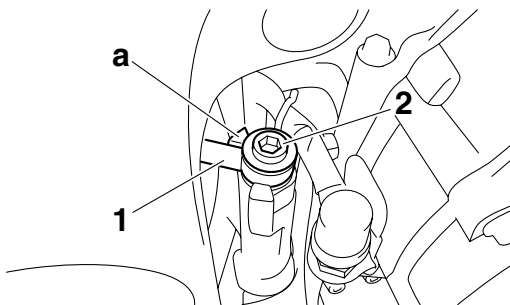

3. Install:

- Brake pedal "1"



Brake pedal pinch bolt
8 Nm (0.8 m·kgf, 5.8 ft·lbf)
Brake pedal bolt
8 Nm (0.8 m·kgf, 5.8 ft·lbf)

TIP

Align the punch mark "a" on the brake pedal with the punch mark "b" on the brake pedal pivot shaft.

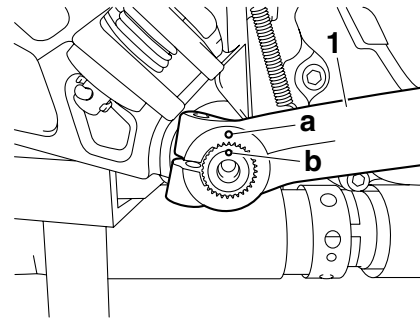

4. Fill:

- Brake fluid reservoir (with the specified amount of the recommended brake fluid)



Recommended fluid
DOT 4

EWA13090

WARNING

- Use only the designated brake fluid. Other brake fluids may cause the rubber seals to deteriorate, causing leakage and poor brake performance.
- Refill with the same type of brake fluid that is already in the system. Mixing brake fluids may result in a harmful chemical reaction, leading to poor brake performance.
- When refilling, be careful that water does not enter the brake fluid reservoir. Water will significantly lower the boiling point of the brake fluid and could cause vapor lock.

ECA13540

NOTICE

Brake fluid may damage painted surfaces and plastic parts. Therefore, always clean up any spilt brake fluid immediately.

5. Bleed:

- Brake system
Refer to "BLEEDING THE HYDRAULIC BRAKE SYSTEM (ABS)" on page 3-24.

6. Check:

- Brake fluid level
Below the minimum level mark "a" → Add the recommended brake fluid to the proper level. Refer to "CHECKING THE BRAKE FLUID LEVEL" on page 3-22.

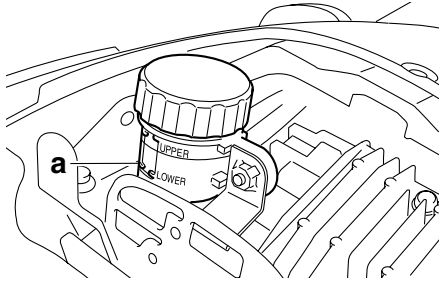

7. Check:

- Brake pedal operation
Soft or spongy feeling → Bleed the brake system.
Refer to “BLEEDING THE HYDRAULIC BRAKE SYSTEM (ABS)” on page 3-24.

8. Adjust:

- Rear brake light operation timing
Refer to “ADJUSTING THE REAR BRAKE LIGHT SWITCH” on page 3-23.

EAS22760

ABS (ANTI-LOCK BRAKE SYSTEM)

EAS2S31022

ABS COMPONENTS CHART

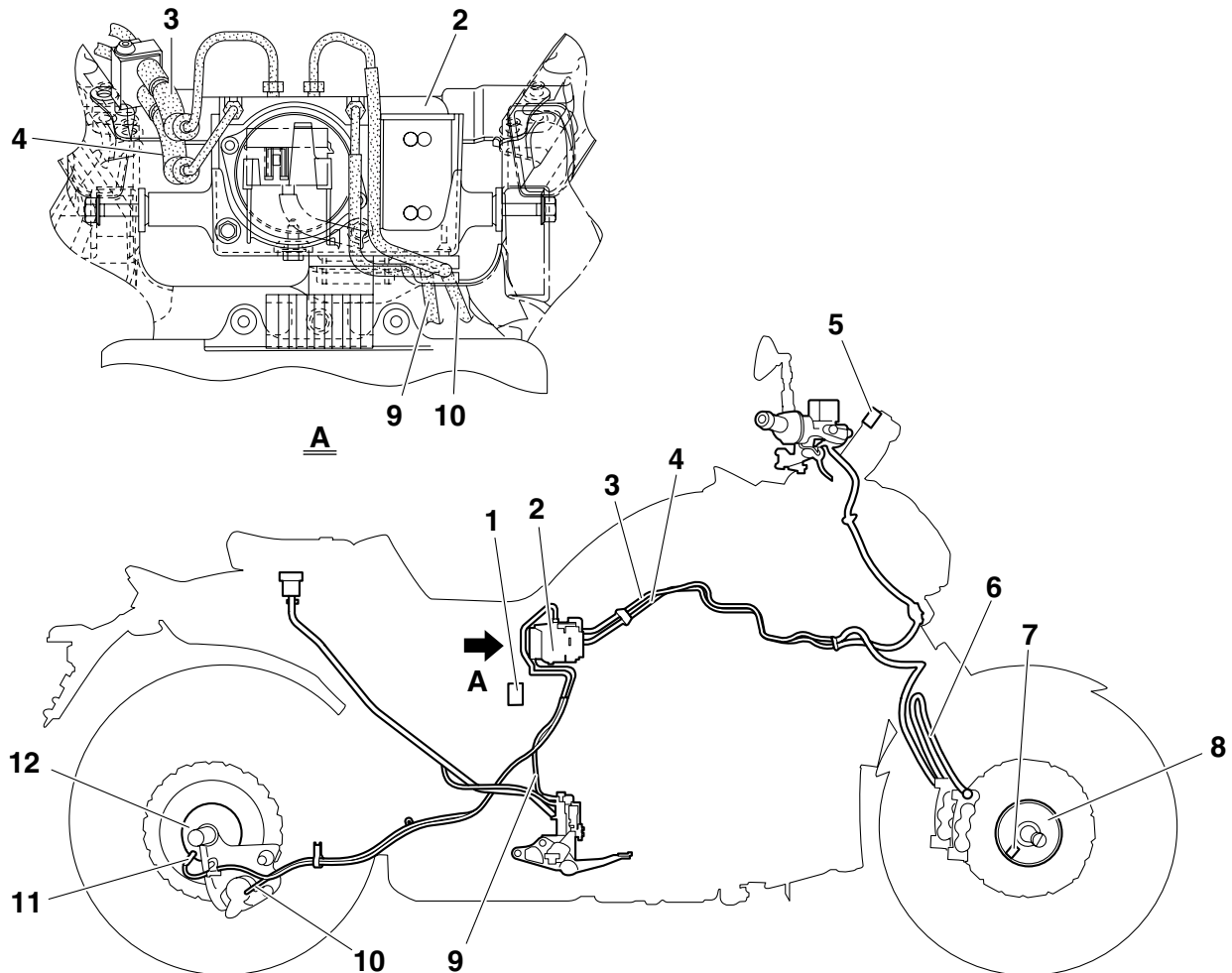

1. ABS test coupler
2. Hydraulic unit assembly
3. Brake hose (hydraulic unit to left front brake caliper)
4. Brake hose (front brake master cylinder to hydraulic unit)
5. ABS warning light
6. Brake hose (left front brake caliper to right front brake caliper)
7. Front wheel sensor
8. Front wheel sensor rotor
9. Brake hose (rear brake master cylinder to hydraulic unit)
10. Brake hose (hydraulic unit to rear brake caliper)
11. Rear wheel sensor
12. Rear wheel sensor rotor

ABS (ANTI-LOCK BRAKE SYSTEM)

Removing the hydraulic unit assembly

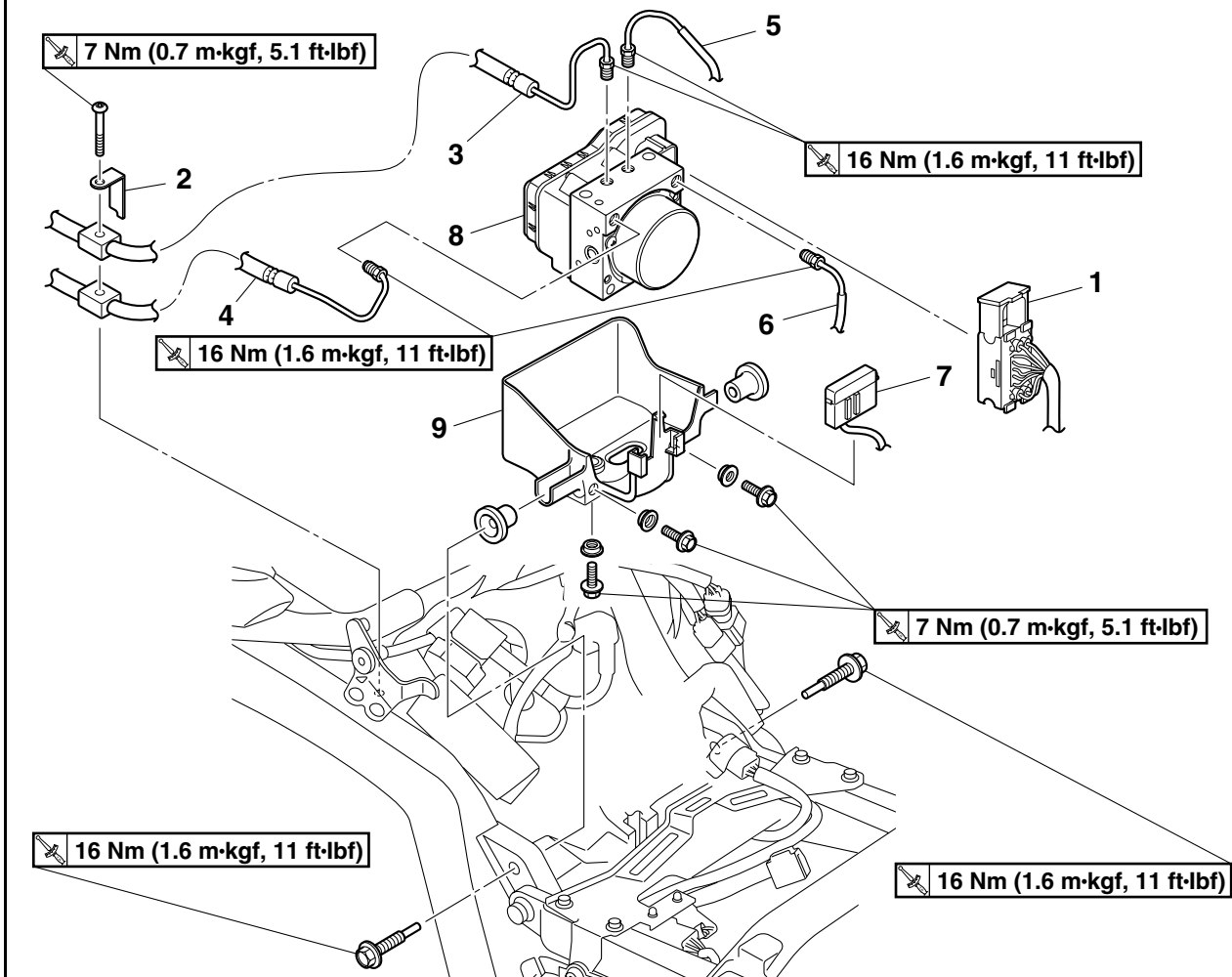

Order	Job/Parts to remove	Q'ty	Remarks
	Brake fluid		Drain. Refer to "BLEEDING THE HYDRAULIC BRAKE SYSTEM (ABS)" on page 3-24.
	Rider seat/Top cover/Battery		Refer to "GENERAL CHASSIS" on page 4-1.
1	ABS ECU coupler	1	Disconnect.
2	Brake hose holder	1	
3	Brake hose (hydraulic unit to left front brake caliper)	1	Disconnect.
4	Brake hose (front brake master cylinder to hydraulic unit)	1	Disconnect.
5	Brake hose (hydraulic unit to rear brake caliper)	1	Disconnect.
6	Brake hose (rear brake master cylinder to hydraulic unit)	1	Disconnect.
7	Fuse box 2	1	
8	Hydraulic unit assembly	1	
9	Hydraulic unit assembly box	1	
			For installation, reverse the removal procedure.

ABS (ANTI-LOCK BRAKE SYSTEM)

EAS2S31023

REMOVING THE HYDRAULIC UNIT ASSEMBLY

ECA2S31024

NOTICE

Unless necessary, avoid removing and installing the brake pipes of the hydraulic unit assembly.

EWA13930

WARNING

Refill with the same type of brake fluid that is already in the system. Mixing fluids may result in a harmful chemical reaction, leading to poor braking performance.

ECA2S31025

NOTICE

- Handle the ABS components with care since they have been accurately adjusted. Keep them away from dirt and do not subject them to shocks.
- Do not turn the main switch to “ON” when removing the hydraulic unit assembly.
- Do not clean with compressed air.
- Do not reuse the brake fluid.
- Brake fluid may damage painted surfaces and plastic parts. Therefore, always clean up any spilt brake fluid immediately.
- Do not allow any brake fluid to contact the couplers. Brake fluid may damage the couplers and cause bad contacts.
- If the union bolts for the hydraulic unit assembly have been removed, be sure to tighten them to the specified torque and bleed the brake system.

1. Disconnect:
 - ABS ECU coupler “1”

TIP

Pull the coupler ejection slider up to disconnect the ABS ECU coupler.

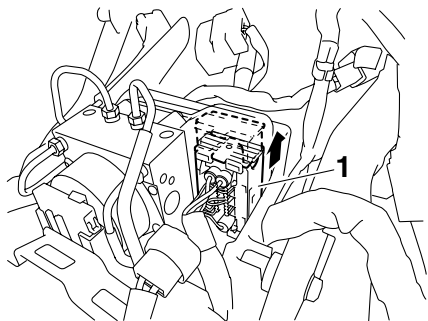

2. Remove:
 - Brake hoses

TIP

Do not operate the brake lever and brake pedal while removing the brake hoses.

ECA2S31031

NOTICE

When removing the brake hoses, cover the area around the hydraulic unit assembly to catch any spilt brake fluid. Do not allow the brake fluid to contact other parts.

3. Remove:
 - Hydraulic unit assembly “1”

TIP

- To avoid brake fluid leakage and to prevent foreign materials from entering the hydraulic unit assembly, insert a rubber plug “a” or a bolt (M10 × 1.00) into each flare nut hole.
- When using a bolt, do not tighten the bolt until the bolt head touches the hydraulic unit. Otherwise, the brake pipe seating surface could be deformed.

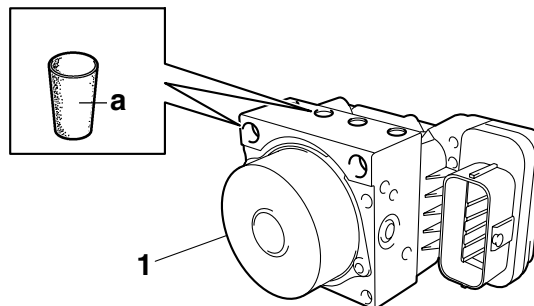

EAS2S31024

CHECKING THE HYDRAULIC UNIT ASSEMBLY

1. Check:
 - Hydraulic unit assembly
Cracks/damage → Replace the hydraulic unit assembly and the brake hoses that are connected to the assembly as a set.

EAS2S31025

CHECKING THE BRAKE HOSES

The following procedure applies to all of the brake hoses.

1. Check:
 - Brake hose end (flare nut)
Damage → Replace the hydraulic unit assembly, brake hoses, and related parts as a set.

ABS (ANTI-LOCK BRAKE SYSTEM)

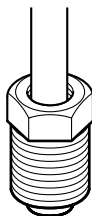

Brake hose flare nut
16 Nm (1.6 m·kgf, 11 ft·lbf)
Brake hose holder bolt
7 Nm (0.7 m·kgf, 5.1 ft·lbf)

EAS2S31026

INSTALLING THE HYDRAULIC UNIT ASSEMBLY

1. Install:
 - Hydraulic unit assembly box
 - Hydraulic unit assembly



Hydraulic unit assembly box bolt
7 Nm (0.7 m·kgf, 5.1 ft·lbf)

TIP

Do not allow any foreign materials to enter the hydraulic unit assembly or the brake hoses when installing the hydraulic unit assembly.

ECA2S31026

NOTICE

Do not remove the rubber plugs or bolts (M10 × 1.0) installed in the flare nut holes before installing the hydraulic unit assembly.

2. Remove:
 - Rubber plugs or bolts (M10 × 1.0)
3. Install:
 - Brake hoses
 - Brake hose holder "1"

TIP

- Temporarily tighten the brake hose flare nuts and brake hose holder bolt.
- Insert the tab "a" on the brake hose holder into the slot "b" in the battery box bracket.

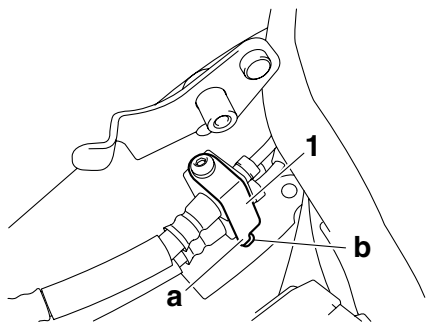

4. Tighten:
 - Brake hose flare nuts
 - Brake hose holder bolt

ECA2S31027

NOTICE

If the brake hose flare nut does not turn easily, replace the hydraulic unit assembly, brake hoses, and related parts as a set.

TIP

- First tighten the brake hose flare nut, then the brake hose holder bolt.
- Do not bend the pipe section of the brake hose when tightening the brake hose flare nuts.
- When tightening the brake hose flare nuts, make sure that the brake pipes are positioned at the angles shown in the illustration.

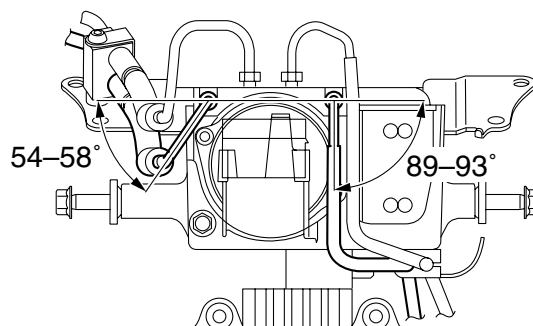
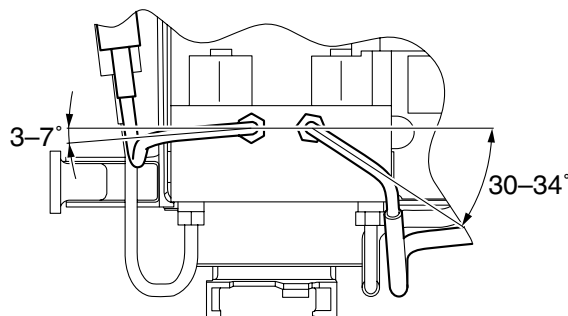

5. Connect:
 - ABS ECU coupler "1"

TIP

Push the coupler ejection slider down until a click is heard, making sure that is installed securely.

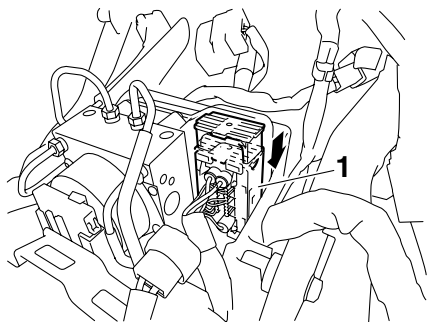

6. Fill:
- Brake master cylinder reservoir
 - Brake fluid reservoir
(with the specified amount of the recommended brake fluid)



EWA13090

WARNING

- Use only the designated brake fluid. Other brake fluids may cause the rubber seals to deteriorate, causing leakage and poor brake performance.
- Refill with the same type of brake fluid that is already in the system. Mixing brake fluids may result in a harmful chemical reaction, leading to poor brake performance.
- When refilling, be careful that water does not enter the brake fluid reservoir. Water will significantly lower the boiling point of the brake fluid and could cause vapor lock.

ECA13540

NOTICE

Brake fluid may damage painted surfaces and plastic parts. Therefore, always clean up any spilt brake fluid immediately.

7. Bleed:
- Brake system
Refer to “BLEEDING THE HYDRAULIC BRAKE SYSTEM (ABS)” on page 3-24.
8. Check the operation of the hydraulic unit according to the brake lever and the brake pedal response. (Refer to “HYDRAULIC UNIT OPERATION TESTS” on page 4-59.)

ECA14770

NOTICE

Always check the operation of the hydraulic unit according to the brake lever and the brake pedal response.

9. Delete the fault codes. (Refer to “[D-1] DELETING THE FAULT CODES” on page 8-114.)
10. Perform a trial run. (Refer to “TRIAL RUN” on page 4-62.)

EAS22800

HYDRAULIC UNIT OPERATION TESTS

The reaction-force pulsating action generated in the brake lever and brake pedal when the ABS is activated can be tested when the vehicle is stopped.

The hydraulic unit operation can be tested using the following two methods.

- Hydraulic unit operation test 1: this test checks the function of the ABS after the system was disassembled, adjusted, or serviced.
- Hydraulic unit operation test 2: this test generates the same reaction-force pulsating action that is generated in the brake lever and brake pedal when the ABS is activated.

Hydraulic unit operation test 1

EWA13120

WARNING

Securely support the vehicle so that there is no danger of it falling over.

TIP

Two people are necessary to perform hydraulic unit operation test 1.

1. Place the vehicle on a suitable stand.
2. Turn the main switch to “OFF”.
3. Remove:
 - Left side cover
 - Top cover
Refer to “GENERAL CHASSIS” on page 4-1.
4. Check:
 - Battery voltage
Lower than 12.8 V → Charge or replace the battery.

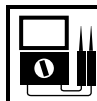

**Battery voltage
Higher than 12.8 V**

TIP

- If the battery voltage is lower than 12.8 V, charge the battery, and then perform hydraulic unit operation test 1.
- If the battery voltage is lower than 10 V, the ABS warning light comes on and the ABS does not operate.

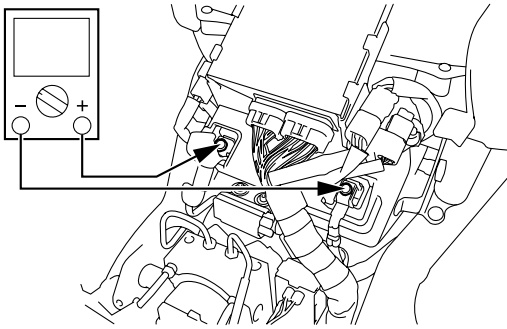

5. Connect the test coupler adapter “1” to the ABS test coupler “2”.



Test coupler adapter
90890-03149

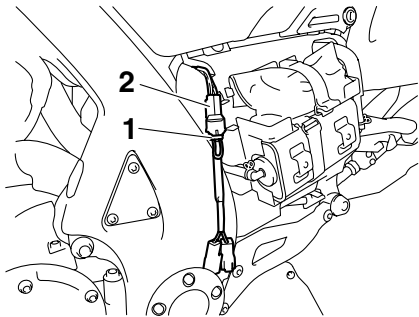

6. Turn the main switch to “ON” while operating the brake lever and the brake pedal simultaneously.

TIP

Do not push the start switch when turning the main switch to “ON”, otherwise the operation test will not begin.

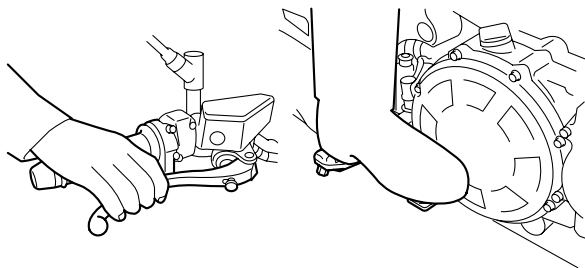

7. Check:

- Hydraulic unit operation
When the main switch is turned to “ON”, a single pulse will be generated in the brake lever “1”, brake pedal “2”, and again in the brake lever “1”, in this order.

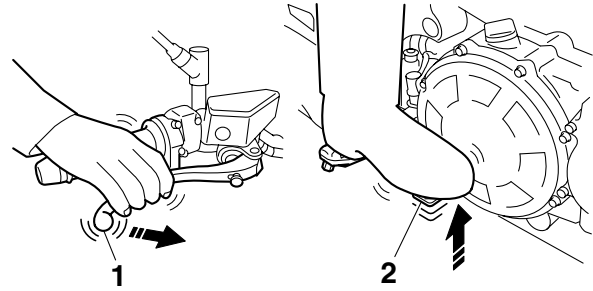

ECA2S31028

NOTICE

- Check that the pulse is felt in the brake lever, brake pedal, and again in the brake lever, in this order.
- If the pulse is felt in the brake pedal before it is felt in the brake lever, check that the brake hoses and brake pipes are connected correctly to the hydraulic unit assembly.
- If the pulse is hardly felt in either the brake lever or brake pedal, check that the brake hoses and brake pipes are connected correctly to the hydraulic unit assembly.

- If the operation of the hydraulic unit is normal, delete all of the fault codes.

Hydraulic unit operation test 2

EWA13120

WARNING

Securely support the vehicle so that there is no danger of it falling over.

1. Place the vehicle on a suitable stand.
2. Turn the main switch to “OFF”.
3. Remove:
 - Left side cover
 - Top cover
 Refer to “GENERAL CHASSIS” on page 4-1.
4. Check:
 - Battery voltage
Lower than 12.8 V → Charge or replace the battery.



Battery voltage
Higher than 12.8 V

TIP

- If the battery voltage is lower than 12.8 V, charge the battery, and then perform hydraulic unit operation test 2.
- If the battery voltage is lower than 10 V, the ABS warning light comes on and the ABS does not operate.

ABS (ANTI-LOCK BRAKE SYSTEM)

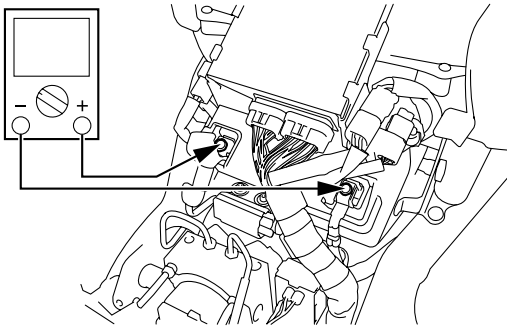

5. Connect the test coupler adapter "1" to the ABS test coupler "2".



**Test coupler adapter
90890-03149**

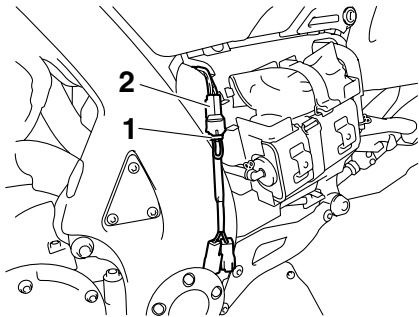

6. Set the engine stop switch "1" to "OFF".
7. Turn the main switch to "ON".

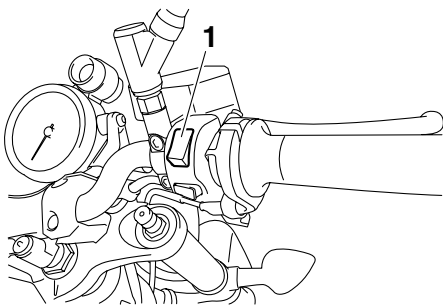

8. Push the start switch "1" for at least 4 seconds.

ECA14790

NOTICE

Do not operate the brake lever or the brake pedal.

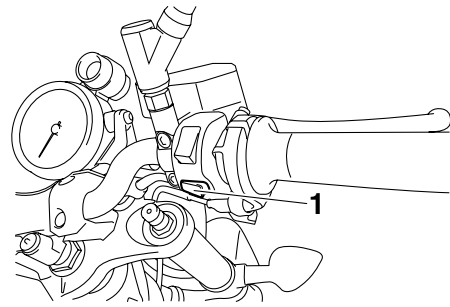

9. After releasing the start switch, operate the brake lever and the brake pedal simultaneously.

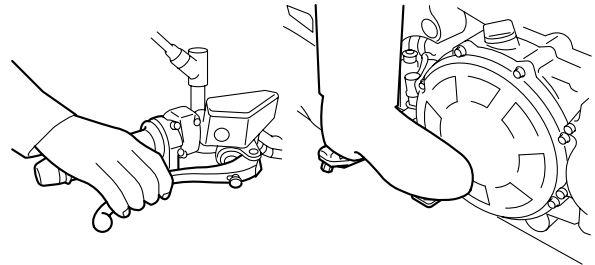

10. A reaction-force pulsating action is generated in the brake lever "1" 0.5 second after the brake lever and the brake pedal are operated simultaneously and continues for approximately 1.5 seconds.

TIP

- The reaction-force pulsating action consists of quick pulses.
- Be sure to continue operating the brake lever and brake pedal even after the pulsating action has stopped.

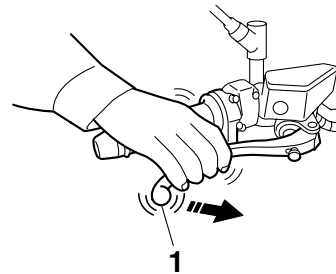

11. After the pulsating action has stopped in the brake lever, it is generated in the brake pedal "1" 0.5 second later and continues for approximately 2 seconds.

TIP

- The reaction-force pulsating action consists of quick pulses.

- Be sure to continue operating the brake lever and brake pedal even after the pulsating action has stopped.

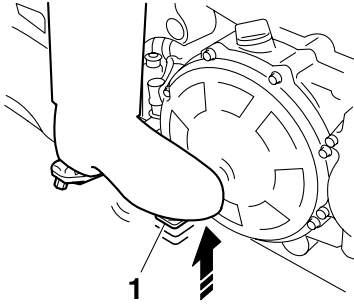

12. After the pulsating action has stopped in the brake pedal, it is generated in the brake lever 0.5 second later and continues for approximately 1.5 seconds.

TIP

The reaction-force pulsating action consists of quick pulses.

ECA2S31029

NOTICE

- Check that the pulsating action is felt in the brake lever, brake pedal, and again in the brake lever, in this order.
- If the pulsating action is felt in the brake pedal before it is felt in the brake lever, check that the brake hoses and brake pipes are connected correctly to the hydraulic unit assembly.
- If the pulsating action is hardly felt in either the brake lever or brake pedal, check that the brake hoses and brake pipes are connected correctly to the hydraulic unit assembly.

13. Turn the main switch to “OFF”.
14. Remove the test coupler adapter from the ABS test coupler.
15. Turn the main switch to “ON”.
16. Set the engine stop switch to “○”.
17. Check for brake fluid leakage around the hydraulic unit.
- Brake fluid leakage → Replace the hydraulic unit, brake pipes, and related parts as a set.

EAS22820

TRIAL RUN

After all checks and servicing are completed, always ensure the vehicle has no problems by performing a trial run at a speed of faster than 30 km/h.

EAS22840

HANDLEBAR

Removing the handlebar

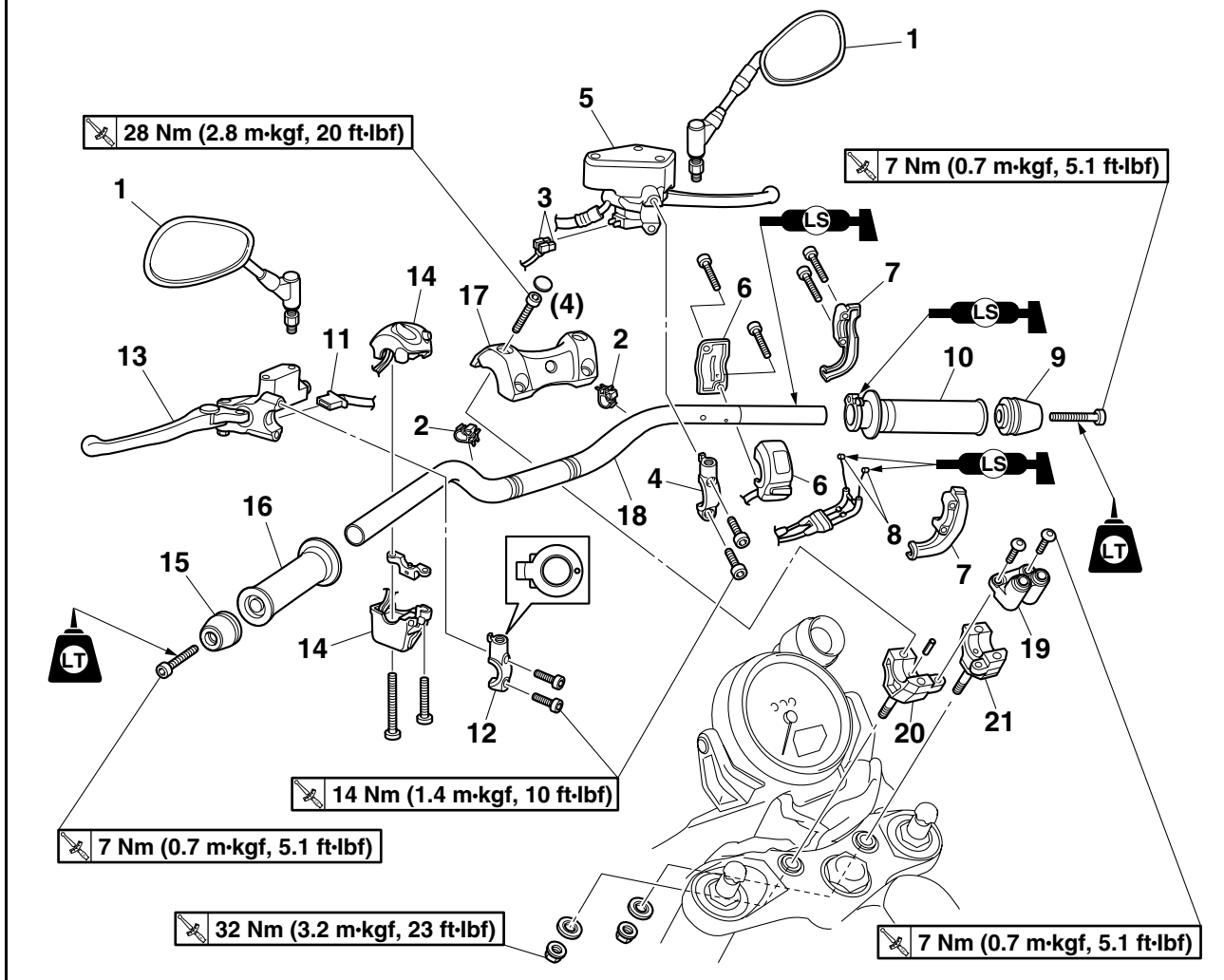

Order	Job/Parts to remove	Q'ty	Remarks
1	Rearview mirror	2	
2	Plastic holder	2	
3	Front brake light switch connector	2	Disconnect.
4	Front brake master cylinder holder	1	
5	Front brake master cylinder assembly	1	
6	Right handlebar switch	1	
7	Throttle cable housing	2	
8	Throttle cable	2	Disconnect.
9	Right grip end	1	
10	Throttle grip	1	
11	Clutch switch coupler	1	Disconnect.
12	Clutch master cylinder holder	1	
13	Clutch master cylinder assembly	1	
14	Left handlebar switch	1	
15	Left grip end	1	
16	Handlebar grip	1	

Removing the handlebar

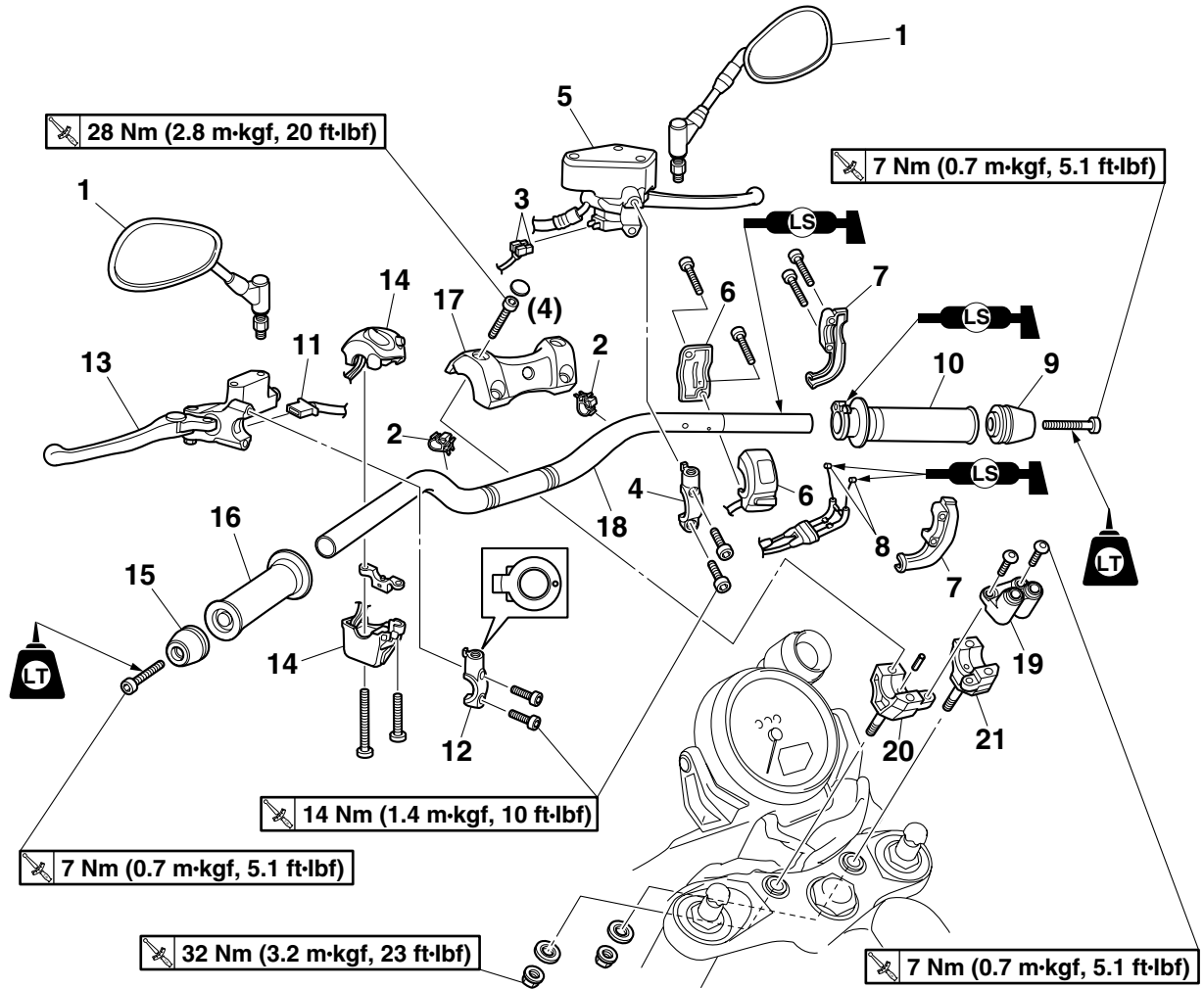

Order	Job/Parts to remove	Q'ty	Remarks
17	Upper handlebar holder	1	
18	Handlebar	1	
19	SELECT/RESET button unit	1	
20	Left lower handlebar holder	1	
21	Right lower handlebar holder	1	
			For installation, reverse the removal procedure.

EAS22860

REMOVING THE HANDLEBAR

1. Stand the vehicle on a level surface.

EWA13120

WARNING

Securely support the vehicle so that there is no danger of it falling over.

2. Remove:
 - Handlebar grip “1”

TIP

Blow compressed air between the left handlebar and the handlebar grip, and gradually push the grip off the handlebar.

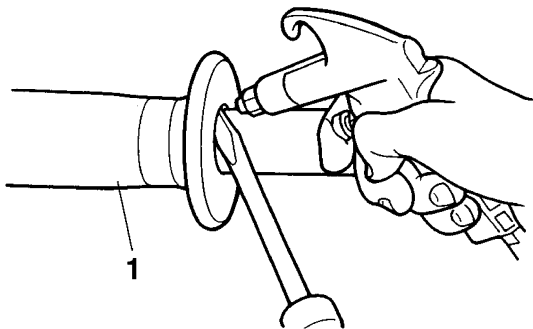

EAS22880

CHECKING THE HANDLEBAR

1. Check:
 - Handlebar
 Bends/cracks/damage → Replace.

EWA13690

WARNING

Do not attempt to straighten a bent handlebar as this may dangerously weaken it.

EAS22931

INSTALLING THE HANDLEBAR

1. Stand the vehicle on a level surface.

EWA13120

WARNING

Securely support the vehicle so that there is no danger of it falling over.

2. Install:
 - Lower handlebar holders
 - Lower handlebar holder nuts (temporarily)
 - SELECT/RESET button unit “1”
 - Handlebar “2”
 - Upper handlebar holder



SELECT/RESET button unit
 7 Nm (0.7 m·kgf, 5.1 ft·lbf)
Upper handlebar holder bolt
 28 Nm (2.8 m·kgf, 20 ft·lbf)

ECA2S31030

NOTICE

First, tighten the bolts on the front side of the handlebar holder, and then on the rear side.

TIP

Align the pin “a” on the left lower handlebar holder with the hole “b” on the handlebar.

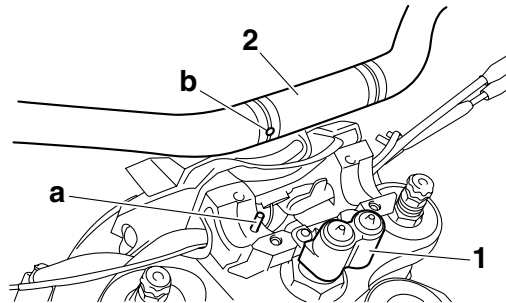

3. Tighten:
 - Lower handlebar holder nuts



Lower handlebar holder nut
 32 Nm (3.2 m·kgf, 23 ft·lbf)

4. Install:
 - Handlebar grip “1”
 - Left grip end “2”



Left grip end bolt
 7 Nm (0.7 m·kgf, 5.1 ft·lbf)
LOCTITE®

- a. Apply a thin coat of rubber adhesive onto the end of the left handlebar.
- b. Slide the handlebar grip over the end of the left handlebar.
- c. Wipe off any excess rubber adhesive with a clean rag.

EWA13700

WARNING

Do not touch the handlebar grip until the rubber adhesive has fully dried.

TIP

There should be 1–3 mm (0.04–0.12 in) of clearance “a” between the handlebar grip and the grip end.

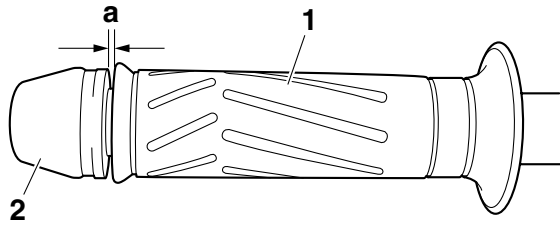

5. Install:

- Left handlebar switch "1"

TIP

Align the projection "a" on the left handlebar switch with the hole "b" in the handlebar.

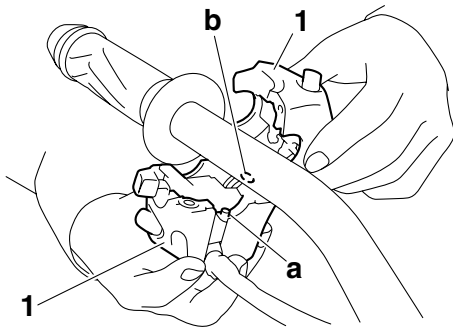

6. Install:

- Clutch master cylinder assembly
- Clutch master cylinder holder "1"



Clutch master cylinder holder bolt
14 Nm (1.4 m·kgf, 10 ft·lbf)

TIP

- The clutch master cylinder holder "1" has a punch mark "a" to distinguish it from the front brake master cylinder holder "2".
- Align the mating surfaces of the clutch master cylinder holder with the punch mark "b" on the handlebar.
- First, tighten the upper bolt, then the lower bolt.

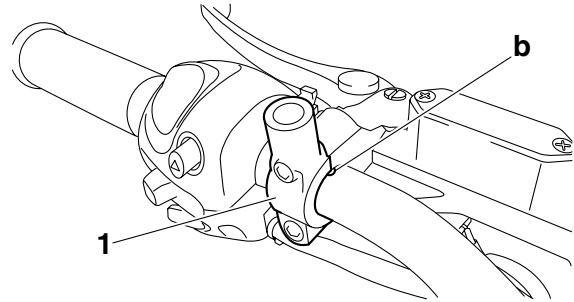
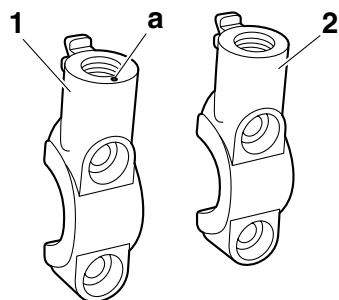

7. Install:

- Throttle grip
- Throttle cables
- Throttle cable housings "1"

TIP

Align the projection "a" on the throttle cable housing with the hole "b" in the handlebar.

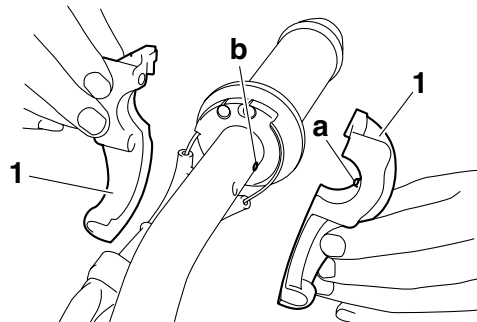

8. Install:

- Right handlebar switch "1"

TIP

Align the projection "a" on the right handlebar switch with the hole "b" on the handlebar.

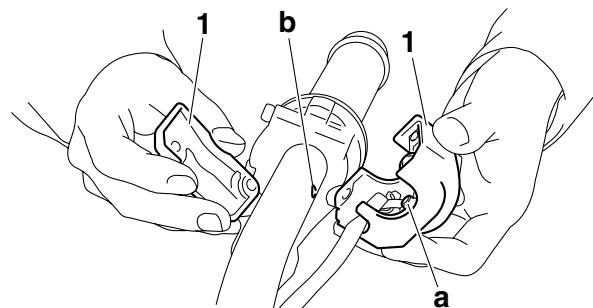

9. Install:

- Front brake master cylinder assembly
- Front brake master cylinder holder "1"



Front brake master cylinder holder bolt
14 Nm (1.4 m·kgf, 10 ft·lbf)

TIP

- Align the mating surfaces of the brake master cylinder holder with the punch mark “a” on the handlebar.
- First, tighten the upper bolt, then the lower bolt.

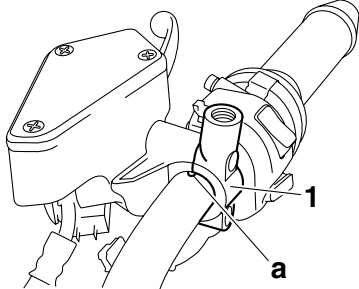

10.Adjust:

- Throttle cable free play
Refer to “ADJUSTING THE THROTTLE CABLE FREE PLAY” on page 3-9.



Throttle cable free play
3.0–5.0 mm (0.12–0.20 in)

EAS22950

FRONT FORK

Removing the front fork legs

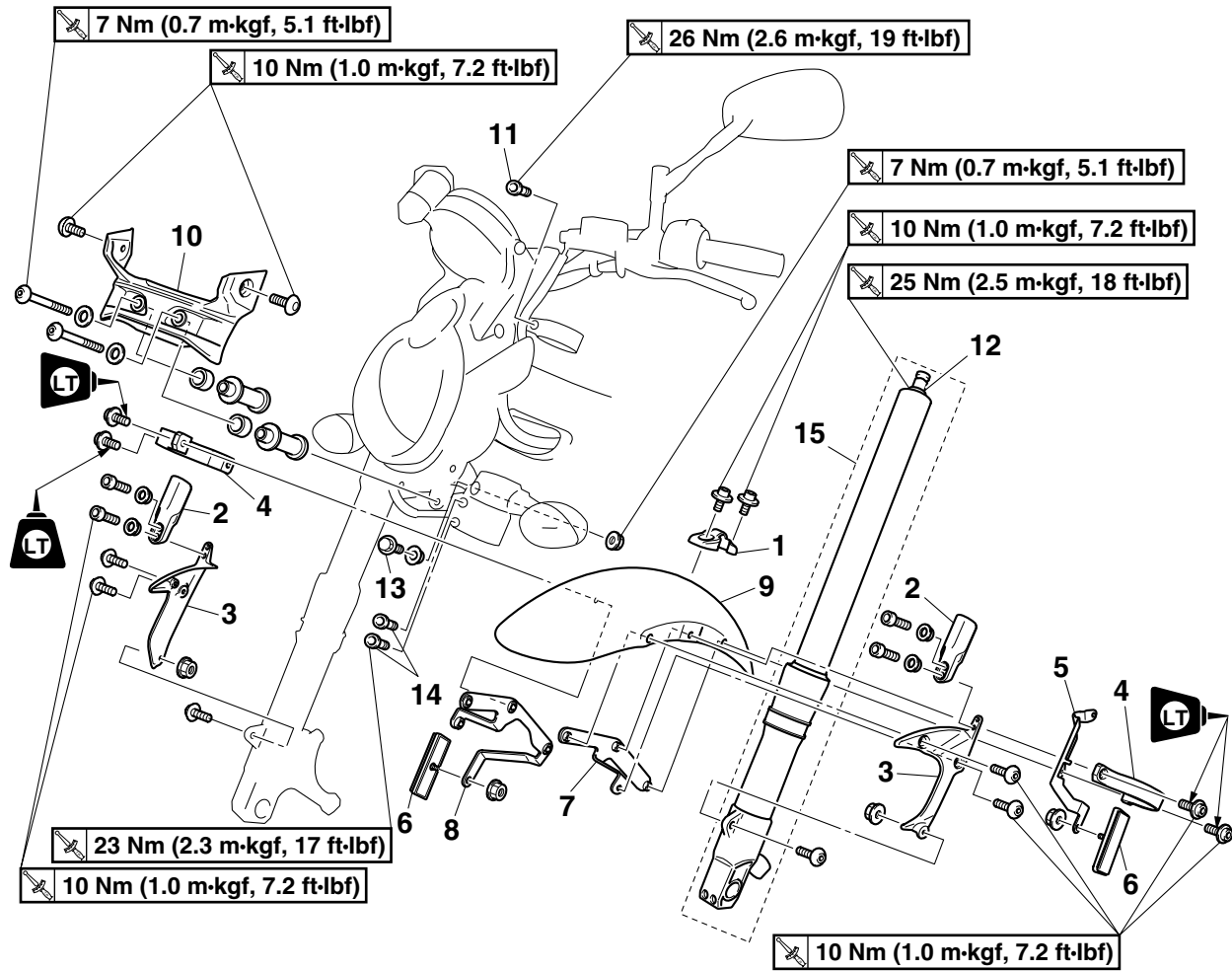

Order	Job/Parts to remove	Q'ty	Remarks
			The following procedure applies to both of the front fork legs.
	Front wheel		Refer to "FRONT WHEEL" on page 4-12.
1	Brake hose holder	1	
2	Fork leg protector	2	
3	Front fender outer bracket	2	
4	Front fender holder/clamp	2	
5	Brake hose guide	1	
6	Front reflector	2	
7	Front fender inner bracket (left)	1	
8	Front fender inner bracket (right)	1	
9	Front fender	1	
10	Headlight lower bracket	1	
11	Upper bracket pinch bolt	1	Loosen.
12	Cap bolt	1	Loosen.
13	Turn signal light pinch bolt	1	Loosen.

FRONT FORK

Removing the front fork legs

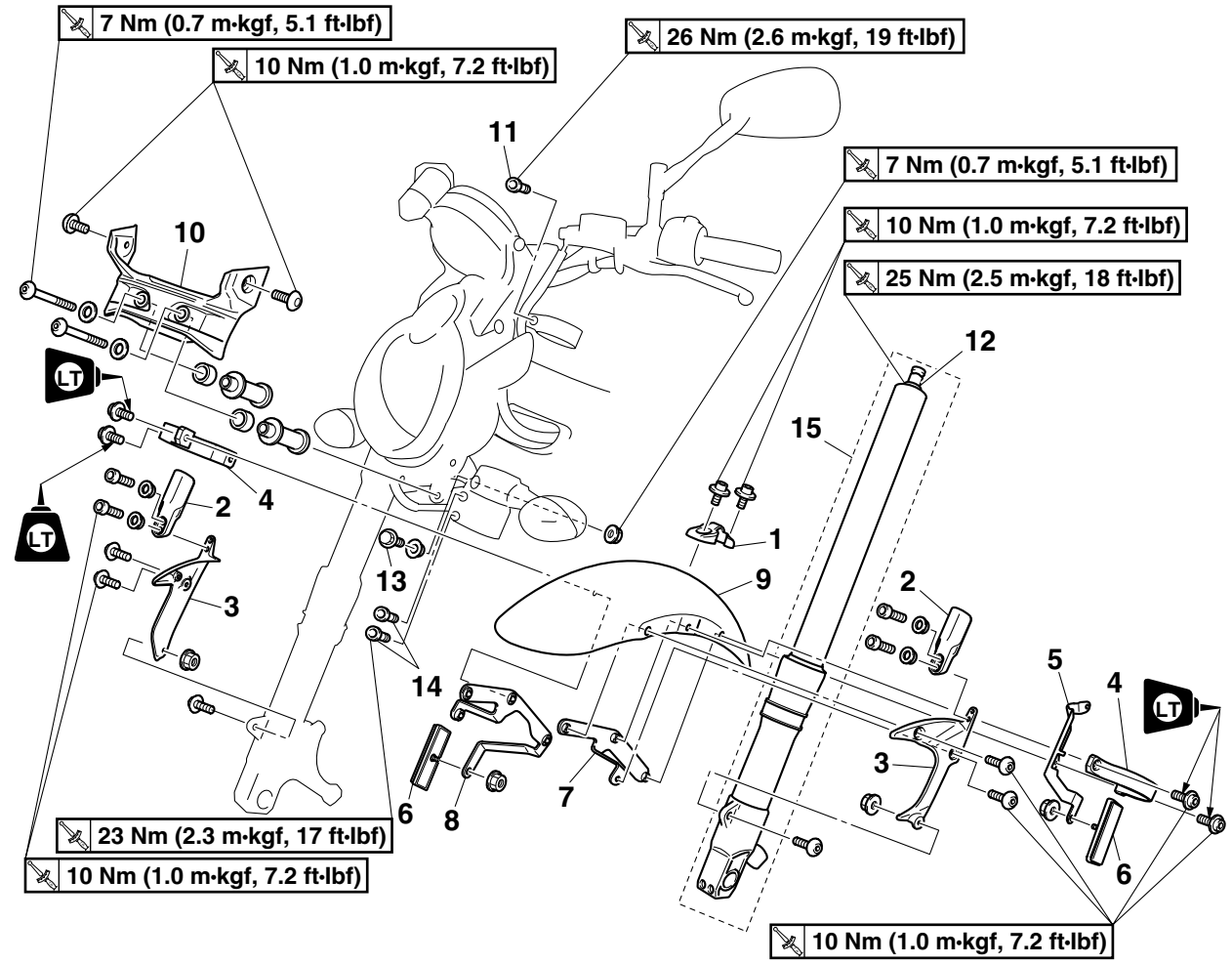

Order	Job/Parts to remove	Q'ty	Remarks
14	Lower bracket pinch bolt	2	Loosen.
15	Front fork leg	1	
			For installation, reverse the removal procedure.

Disassembling the front fork legs

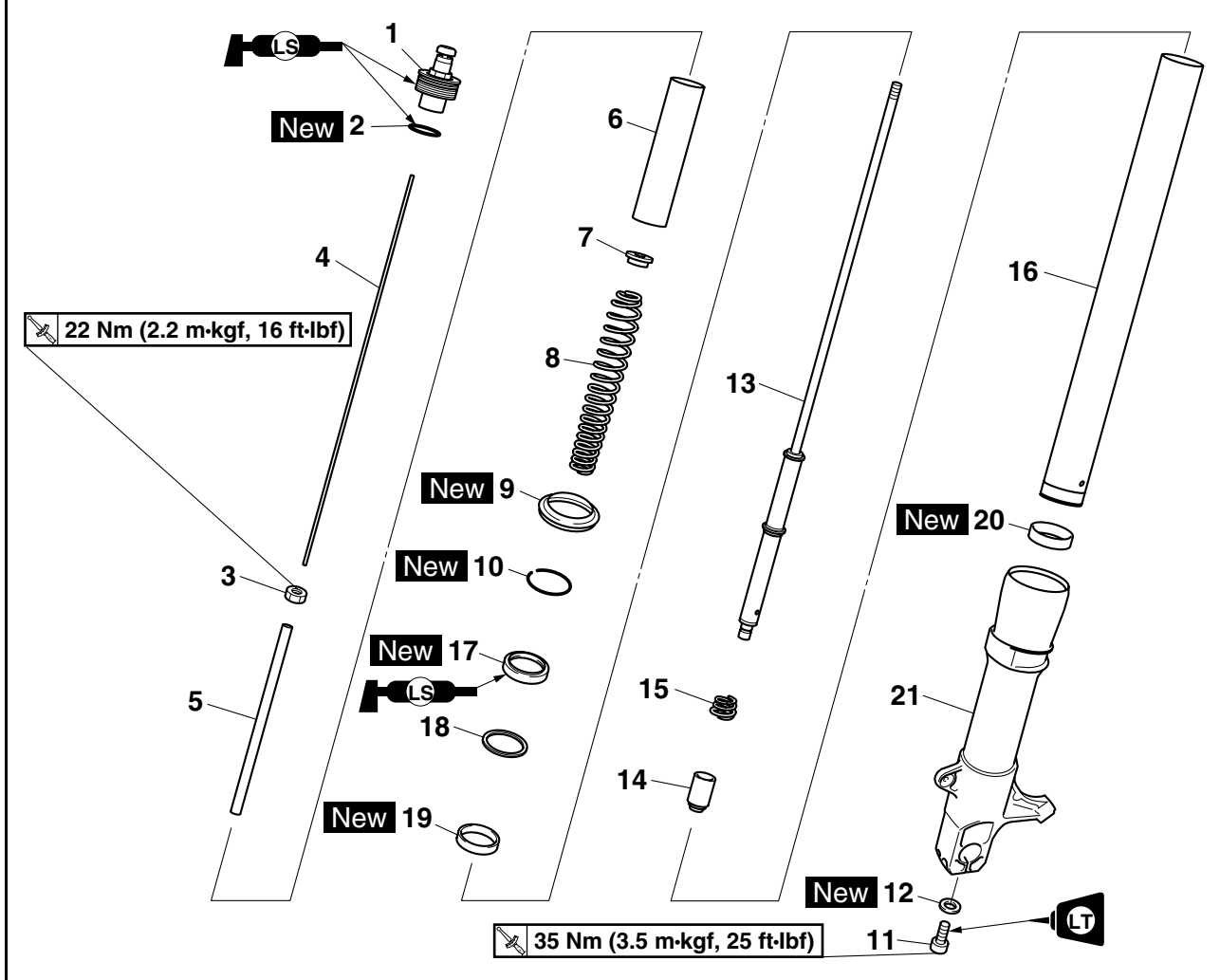

Order	Job/Parts to remove	Q'ty	Remarks
			The following procedure applies to both of the front fork legs.
1	Cap bolt	1	
2	O-ring	1	
3	Locknut	1	
4	Damper adjusting rod	1	
5	Spacer	1	
6	Spring sleeve	1	
7	Spring seat	1	
8	Fork spring	1	
9	Dust seal	1	
10	Oil seal clip	1	
11	Damper rod assembly bolt	1	
12	Copper washer	1	
13	Damper rod assembly	1	
14	Oil flow stopper	1	
15	Spring	1	
16	Inner tube	1	

FRONT FORK

Disassembling the front fork legs

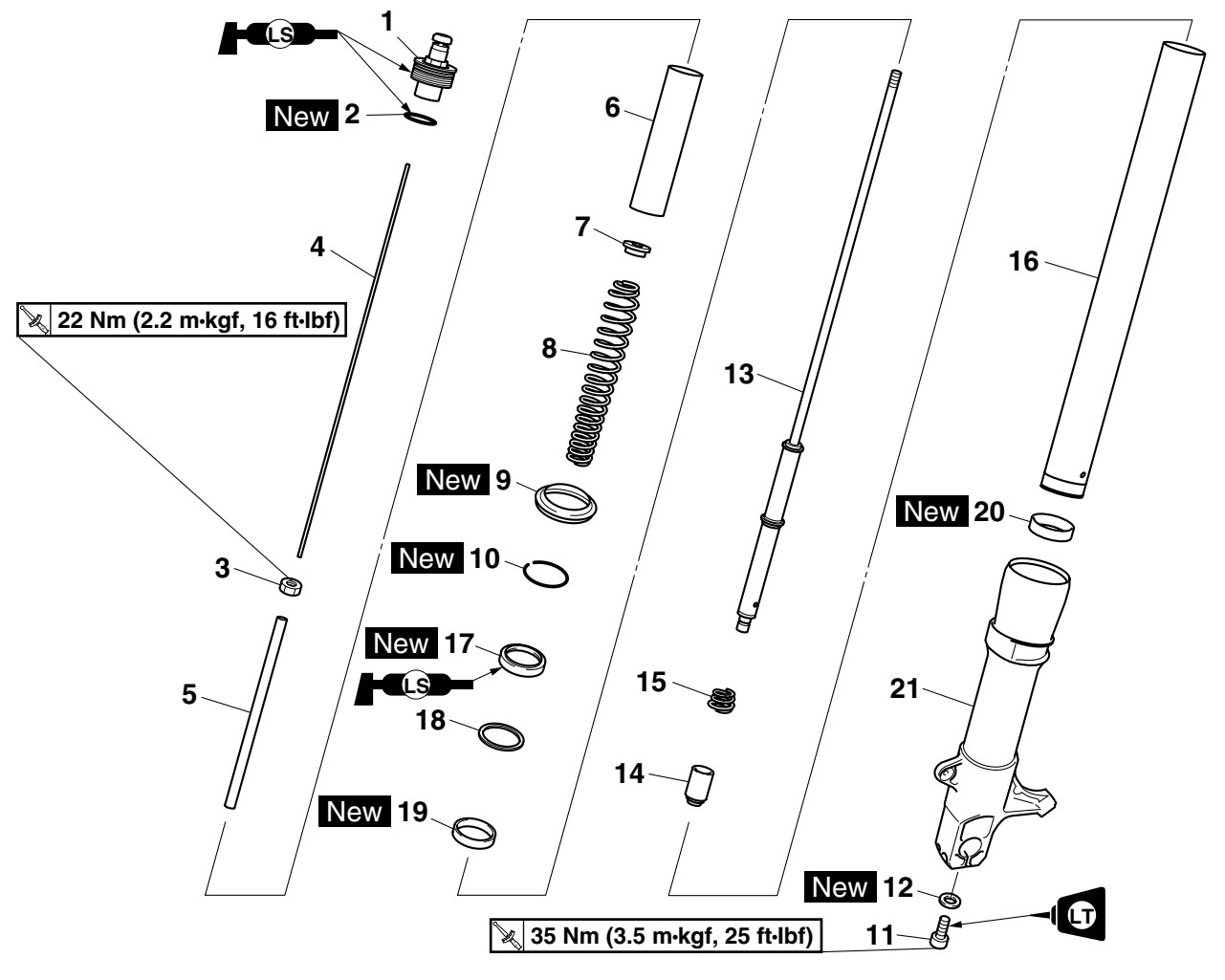

Order	Job/Parts to remove	Q'ty	Remarks
17	Oil seal	1	
18	Washer	1	
19	Outer tube bushing	1	
20	Inner tube bushing	1	
21	Outer tube	1	
			For assembly, reverse the disassembly procedure.

EAS22960

REMOVING THE FRONT FORK LEGS

The following procedure applies to both of the front fork legs.

1. Stand the vehicle on a level surface.

EWA13120

WARNING

Securely support the vehicle so that there is no danger of it falling over.

TIP

Place the vehicle on a suitable stand so that the front wheel is elevated.

2. Loosen:

- Upper bracket pinch bolt "1"
- Cap bolt "2"
- Turn signal light pinch bolt "3"
- Lower bracket pinch bolts "4"

EWA13640

WARNING

Before loosening the upper and lower bracket pinch bolts, support the front fork leg.

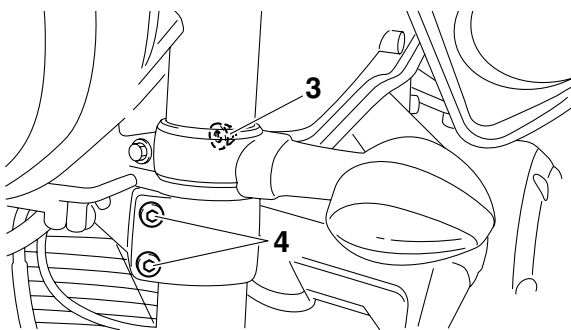
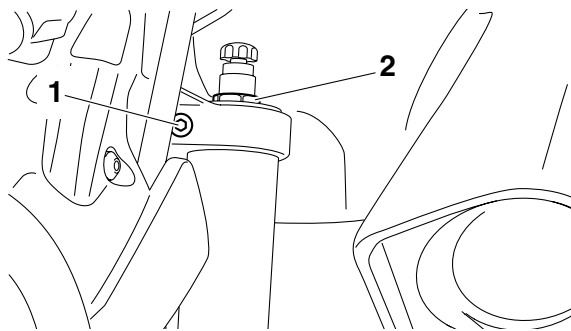

3. Remove:

- Front fork leg

EAS22990

DISASSEMBLING THE FRONT FORK LEGS

The following procedure applies to both of the front fork legs.

1. Hold the locknut "1" and loosen the cap bolt "2".

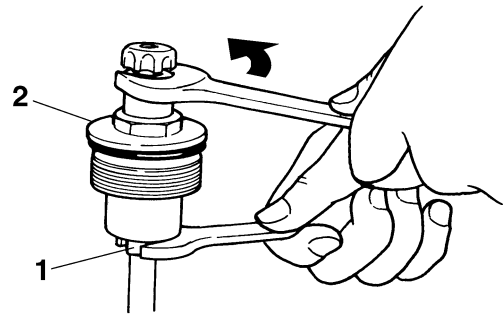

2. Drain:

- Fork oil

TIP

Stroke the inner tube several times while draining the fork oil.

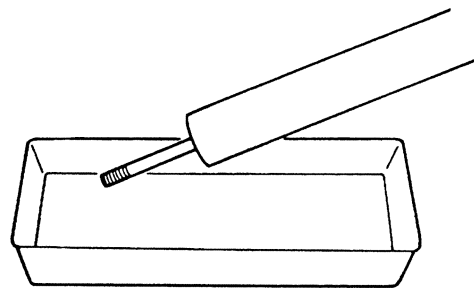

3. Remove:

- Dust seal "1"
- Oil seal clip "2"
(with a flat-head screwdriver)

ECA14180

NOTICE

Do not scratch the inner tube.

TIP

- Do not remove the fork leg protector from the outer tube.
- If the front fork leg protector must be removed, always install a new one.

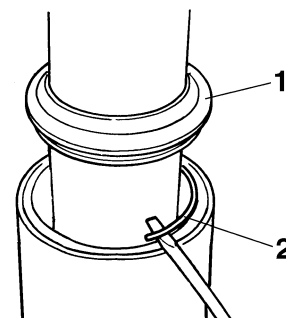

4. Remove:

- Damper rod assembly bolt

TIP

While holding the damper rod with the damper rod holder "1", loosen the damper rod assembly bolt.

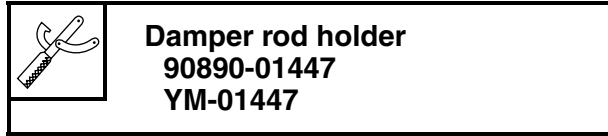

Damper rod holder
90890-01447
YM-01447

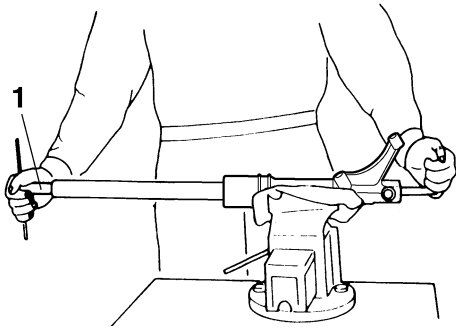

5. Remove:

- Inner tube



- Hold the front fork leg horizontally.
- Securely clamp the brake caliper bracket in a vise with soft jaws.
- Separate the inner tube from the outer tube by pulling the inner tube forcefully but carefully.

ECA14190

NOTICE

- **Excessive force will damage the oil seal and bushing. A damaged oil seal or bushing must be replaced.**
- **Avoid bottoming the inner tube into the outer tube during the above procedure, as the oil flow stopper will be damaged.**

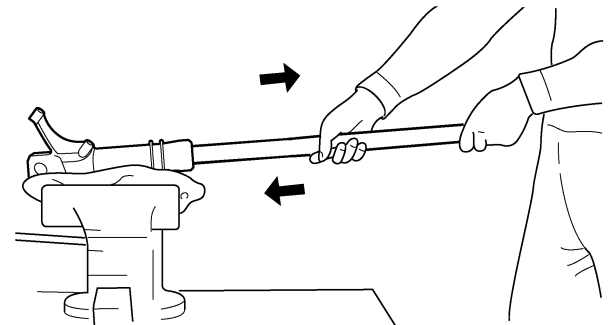

EAS23010

CHECKING THE FRONT FORK LEGS

The following procedure applies to both of the front fork legs.

1. Check:

- Inner tube
 - Outer tube
- Bends/damage/scratches → Replace.

EWA13650

WARNING

Do not attempt to straighten a bent inner tube as this may dangerously weaken it.

2. Measure:

- Spring free length "a"
- Out of specification → Replace.



Fork spring free length
255.0 mm (10.04 in)
Limit
251.0 mm (9.88 in)

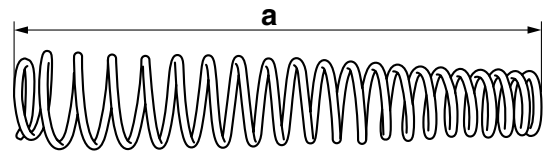

3. Check:

- Damper rod assembly
- Damage/wear → Replace.
Obstruction → Blow out all of the oil passages with compressed air.
 - Oil flow stopper

Damage → Replace.

ECA14200

NOTICE

- **The front fork leg has a built-in damper adjusting rod and a very sophisticated internal construction, which are particularly sensitive to foreign material.**
- **When disassembling and assembling the front fork leg, do not allow any foreign material to enter the front fork.**

4. Check:

- Cap bolt O-ring
- Damage/wear → Replace.

EAS23030

ASSEMBLING THE FRONT FORK LEGS

The following procedure applies to both of the front fork legs.

EWA13660

WARNING

- Make sure the oil levels in both front fork legs are equal.
- Uneven oil levels can result in poor handling and a loss of stability.

TIP

- When assembling the front fork leg, be sure to replace the following parts:
 - Inner tube bushing
 - Outer tube bushing
 - Oil seal
 - Dust seal
- Before assembling the front fork leg, make sure all of the components are clean.

1. Install:

- Spring

TIP

- Install the spring so that the tapered end “A” is facing up as shown.
- Make sure that the top of the spring is seated in the channel “1” on the damper rod assembly.

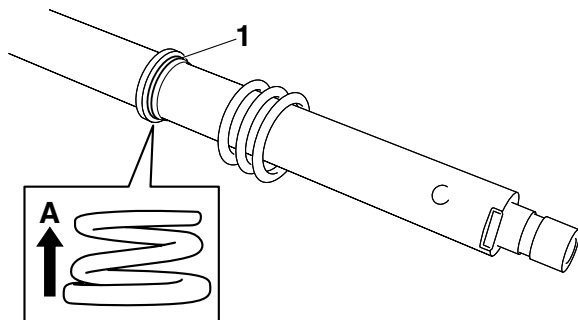

2. Install:

- Inner tube bushing “1” **New**
- Oil flow stopper “2”
- Damper rod assembly “3”

ECA2S31032

NOTICE

Allow the damper rod assembly to slide slowly down the inner tube “4” until it protrudes from the bottom of the inner tube. Be careful not to damage the inner tube.

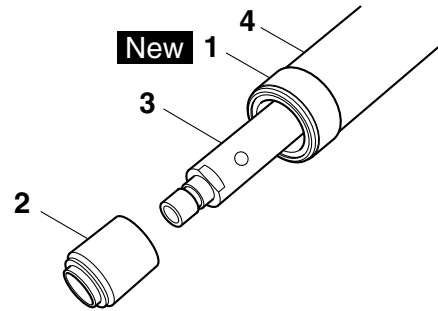

3. Lubricate:

- Inner tube’s outer surface

	Recommended oil Suspension oil M1
---	---

4. Tighten:

- Damper rod assembly bolt

	Damper rod assembly bolt 35 Nm (3.5 m·kgf, 25 ft·lbf) LOCTITE®
---	---

TIP

While holding the damper rod assembly with the damper rod holder “1”, tighten the damper rod assembly bolt.

	Damper rod holder 90890-01447 YM-01447
---	---

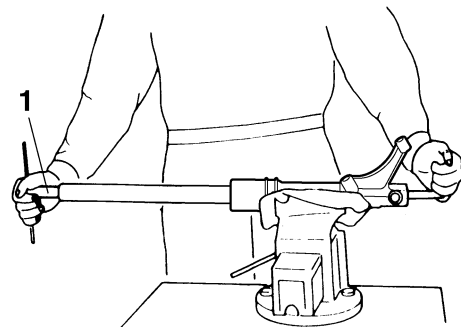

5. Install:

- Outer tube bushing “1” **New**
- Washer “2”
(with the fork seal driver “3”)

	Fork seal driver 90890-01502 YM-A0948
---	--

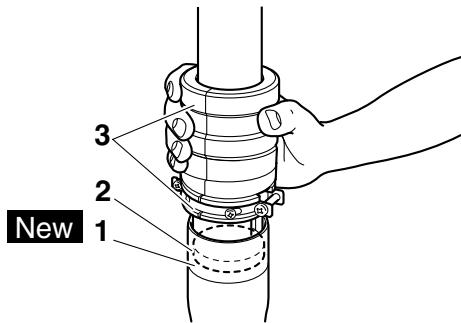

6. Install:
- Oil seal “1”
(with the fork seal driver “2”)

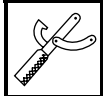

Fork seal driver
90890-01502
YM-A0948

ECA14220

NOTICE

Make sure the numbered side of the oil seal faces up.

TIP

- Before installing the oil seal, lubricate its lips with lithium-soap-based grease.
- Lubricate the outer surface of the inner tube with fork oil.
- Before installing the oil seal, cover the top of the front fork leg with a plastic bag to protect the oil seal during installation.

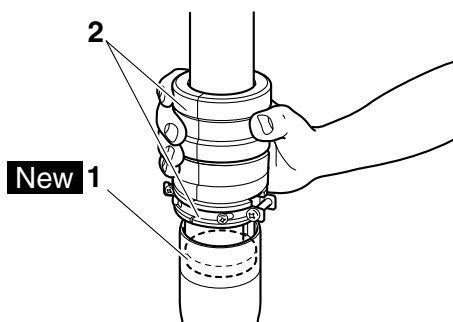
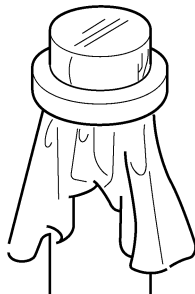

7. Install:
- Oil seal clip “1” **New**

TIP

Adjust the oil seal clip so that it fits into the outer tube’s groove.

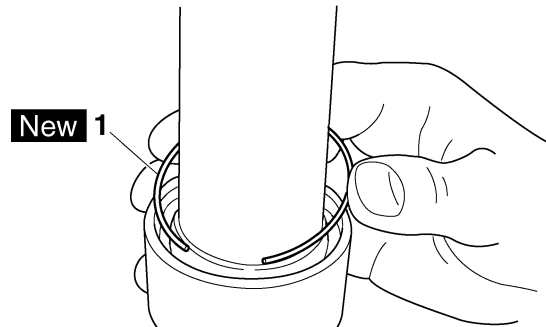

8. Install:
- Dust seal “1” **New**
(with the fork seal driver “2”)



Fork seal driver
90890-01502
YM-A0948

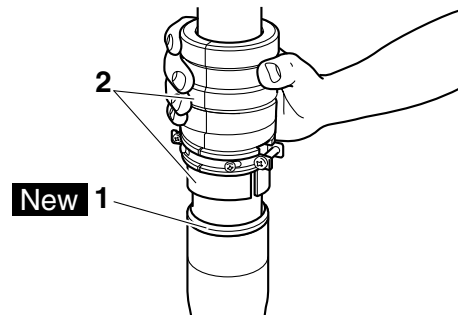

9. Fill:
- Front fork leg
(with the specified amount of the recommended fork oil)



Recommended oil
Suspension oil M1
Quantity
915.0 cm³ (30.94 US oz, 32.27 Imp.oz)

ECA14230

NOTICE

- **Be sure to use the recommended fork oil. Other oils may have an adverse effect on front fork performance.**
- **When disassembling and assembling the front fork leg, do not allow any foreign material to enter the front fork.**

10. After filling the front fork leg, slowly stroke the damper rod assembly "1" up and down (at least ten times) to distribute the fork oil.

TIP

Be sure to stroke the damper rod assembly slowly because the fork oil may spurt out.

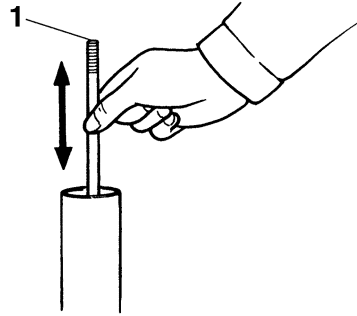

11. Slowly stroke the inner tube "1" up and down.

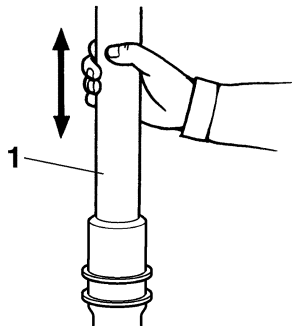

12. Before measuring the fork oil level, wait ten minutes until the oil has settled and the air bubbles have dispersed.

TIP

Be sure to bleed the front fork leg of any residual air.

13. Measure:

- Front fork leg oil level "a" (from the top of the inner tube, with the outer tube fully compressed and without the fork spring)
- Out of specification → Correct.

	Level 104.0 mm (4.09 in)
--	------------------------------------

TIP

- While filling the front fork leg, keep it upright.
- After filling, slowly pump the front fork leg up and down to distribute the fork oil.

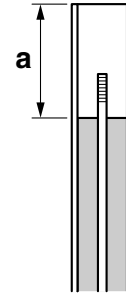

14. Install:

- Fork spring

TIP

Install the fork spring so that the end "A" shown in the illustration is facing up.

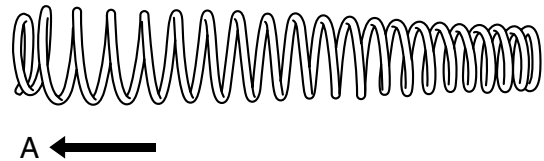

15. Install:

- Locknut "1"
- Damper adjusting rod "2"
- Cap bolt "3"



- Install the locknut "1" and finger tighten it.
- Insert the damper adjusting rod "2".
- Install the cap bolt "3" and finger tighten it.

EWA13670

WARNING

Always use a new cap bolt O-ring.

- Hold the cap bolt and tighten the locknut "1" to specification.

	Locknut 22 Nm (2.2 m·kgf, 16 ft·lbf)
--	--

EAS23090

STEERING HEAD

Removing the coupler holder and brake hose holder

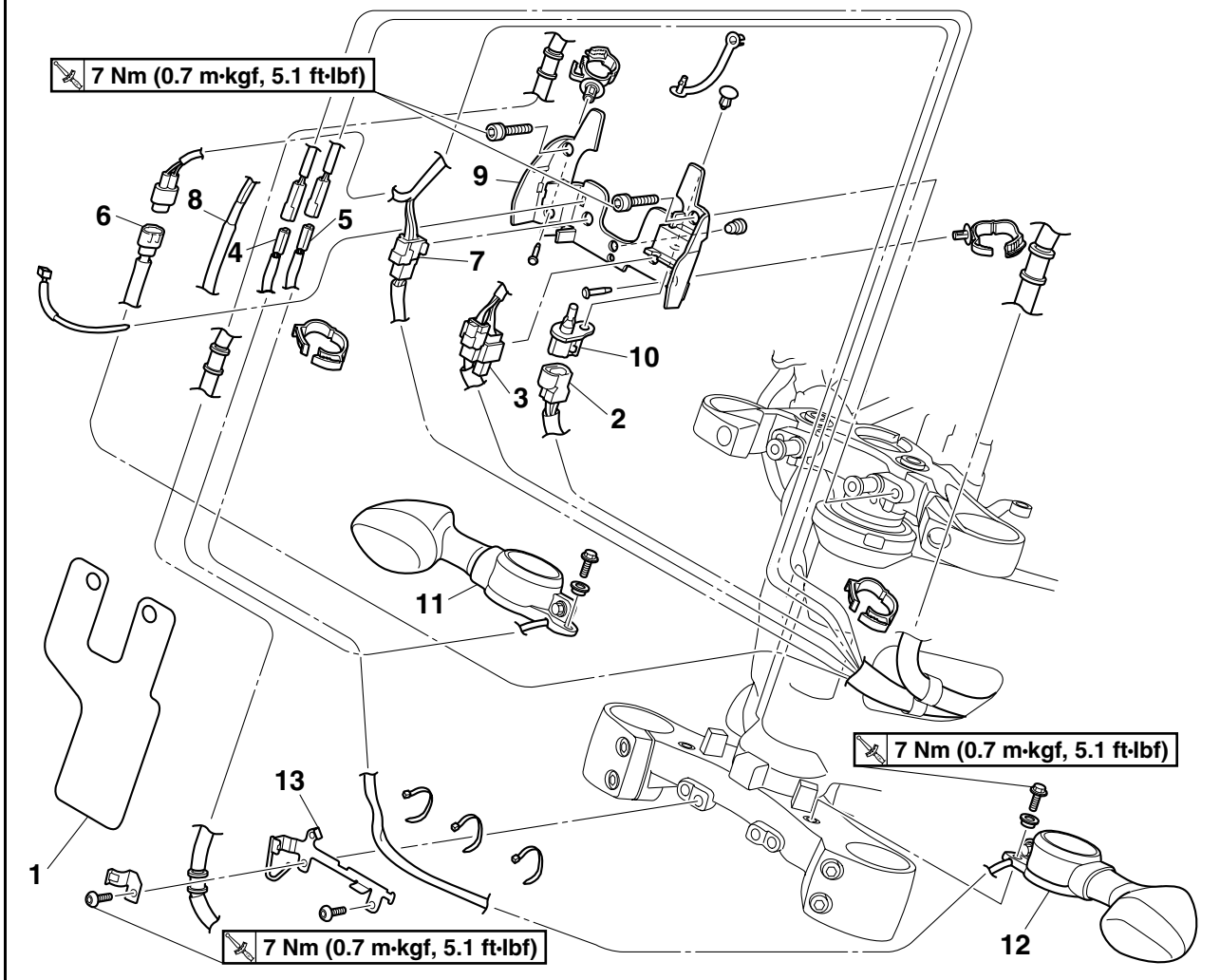

Order	Job/Parts to remove	Q'ty	Remarks
	Front wheel		Refer to "FRONT WHEEL" on page 4-12".
	Handlebar		Refer to "HANDLEBAR" on page 4-63".
	Front fork legs		Refer to "FRONT FORK" on page 4-68".
1	Coupler cover	1	
2	Intake air temperature sensor coupler	1	Disconnect.
3	Left handlebar switch coupler	1	
4	Front right turn signal/position light coupler	1	Disconnect.
5	Front left turn signal/position light coupler	1	Disconnect.
6	Front brake light switch coupler	1	Disconnect.
7	Right handlebar switch coupler	1	
8	SELECT/RESET button unit lead	1	
9	Coupler holder	1	
10	Intake air temperature sensor	1	
11	Front right turn signal/position light	1	
12	Front left turn signal/position light	1	

STEERING HEAD

Removing the coupler holder and brake hose holder

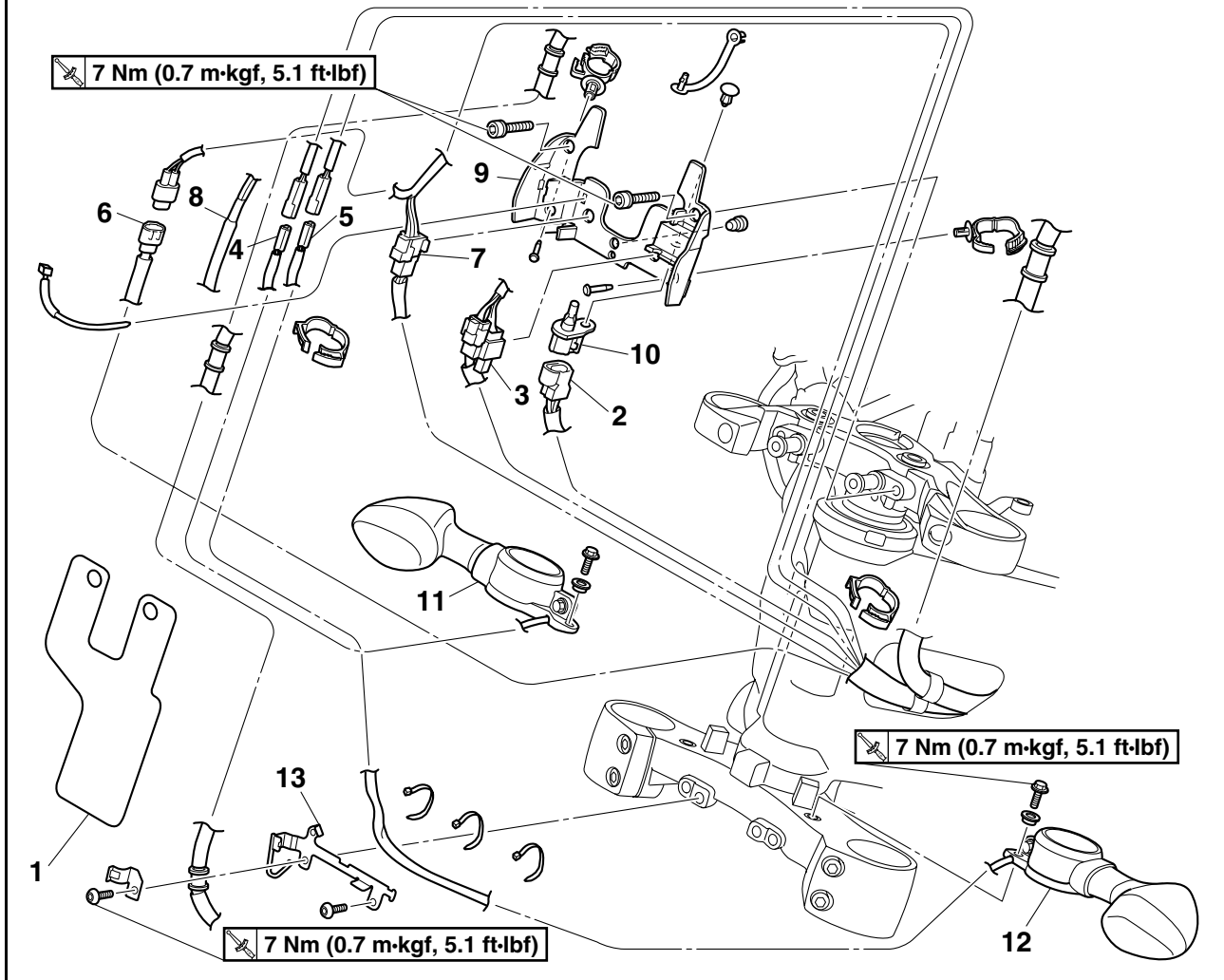

Order	Job/Parts to remove	Q'ty	Remarks
13	Brake hose guide	1	
			For installation, reverse the removal procedure.

STEERING HEAD

Removing the lower bracket

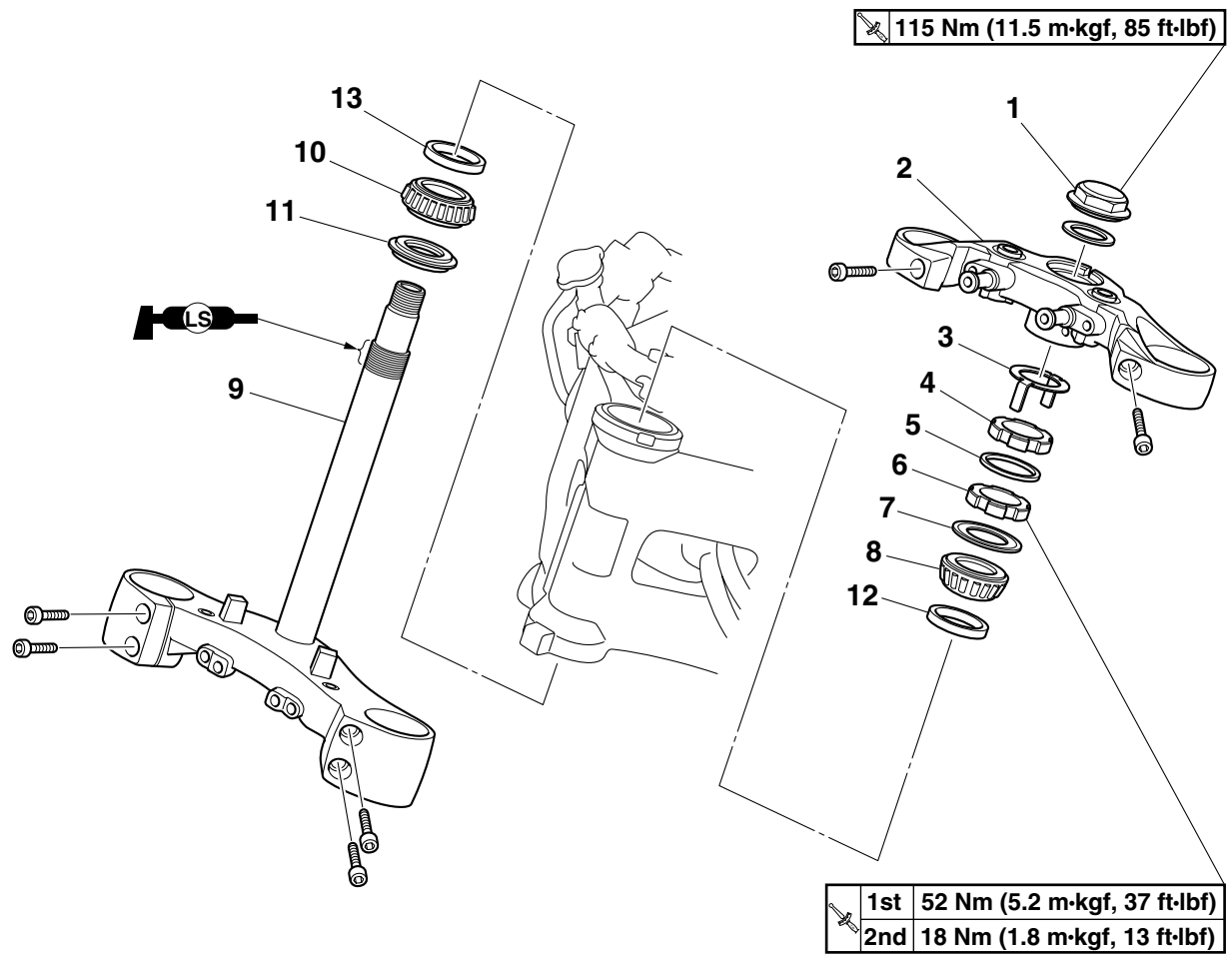

Order	Job/Parts to remove	Q'ty	Remarks
1	Steering stem nut	1	
2	Upper bracket	1	
3	Lock washer	1	
4	Upper ring nut	1	
5	Rubber washer	1	
6	Lower ring nut	1	
7	Upper bearing cover	1	
8	Upper bearing	1	
9	Lower bracket	1	
10	Lower bearing	1	
11	Dust seal	1	
12	Upper bearing race	1	
13	Lower bearing race	1	
			For installation, reverse the removal procedure.

EAS23110

REMOVING THE LOWER BRACKET

1. Stand the vehicle on a level surface.

EWA13120

WARNING

Securely support the vehicle so that there is no danger of it falling over.

2. Remove:

- Upper ring nut
- Rubber washer
- Lower ring nut "1"
- Lower bracket

EWA13730

WARNING

Securely support the lower bracket so that there is no danger of it falling.

TIP

Remove the lower ring nut with the steering nut wrench "2".

	Steering nut wrench 90890-01403
	Exhaust flange nut wrench YU-A9472

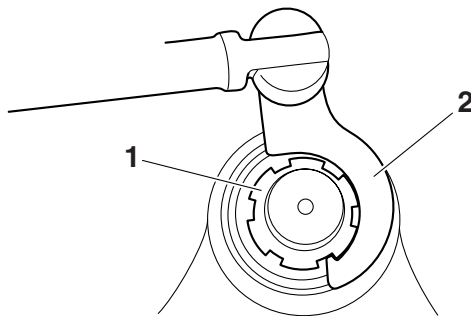

EAS23120

CHECKING THE STEERING HEAD

1. Wash:

- Bearings
- Bearing races

	Recommended cleaning solvent Kerosene
---	--

2. Check:

- Bearings
 - Bearing races
- Damage/pitting → Replace.

3. Replace:

- Bearings
- Bearing races



- a. Remove the bearing races from the steering head pipe "1" with a long rod "2" and hammer.
- b. Remove the bearing race from the lower bracket "3" with a floor chisel "4" and hammer.
- c. Install a new dust seal and new bearing races.

ECA14270

NOTICE

If the bearing race is not installed properly, the steering head pipe could be damaged.

TIP

- Always replace the bearings and bearing races as a set.
- Whenever the steering head is disassembled, replace the dust seal.

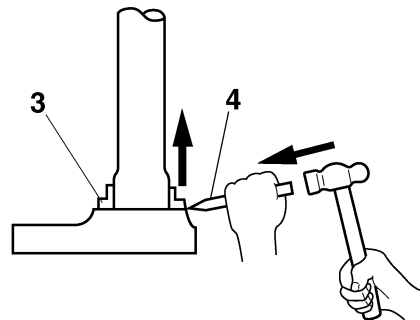
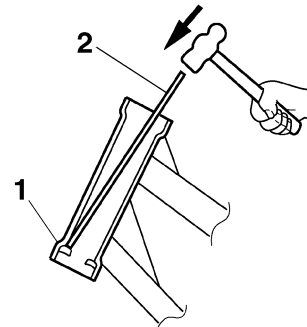

4. Check:

- Upper bracket
 - Lower bracket (along with the steering stem)
- Bends/cracks/damage → Replace.

EAS23140

INSTALLING THE STEERING HEAD

1. Lubricate:

- Upper bearing
- Lower bearing
- Bearing races

	Recommended lubricant Lithium-soap-based grease
---	--

2. Install:

- Lower ring nut “1”
- Rubber washer “2”
- Upper ring nut “3”
- Lock washer “4”

Refer to “CHECKING AND ADJUSTING THE STEERING HEAD” on page 3-26.

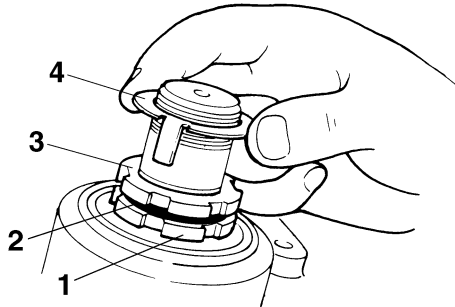

3. Install:

- Upper bracket
- Steering stem nut

TIP

Temporarily tighten the steering stem nut.

4. Install:

- Front fork legs
- Refer to “FRONT FORK” on page 4-68.

TIP

Temporarily tighten the upper and lower bracket pinch bolts.

5. Tighten:

- Steering stem nut

	Steering stem nut 115 Nm (11.5 m·kgf, 85 ft·lbf)
---	---

REAR SHOCK ABSORBER ASSEMBLY

EAS23160

REAR SHOCK ABSORBER ASSEMBLY

Removing the rear shock absorber assembly

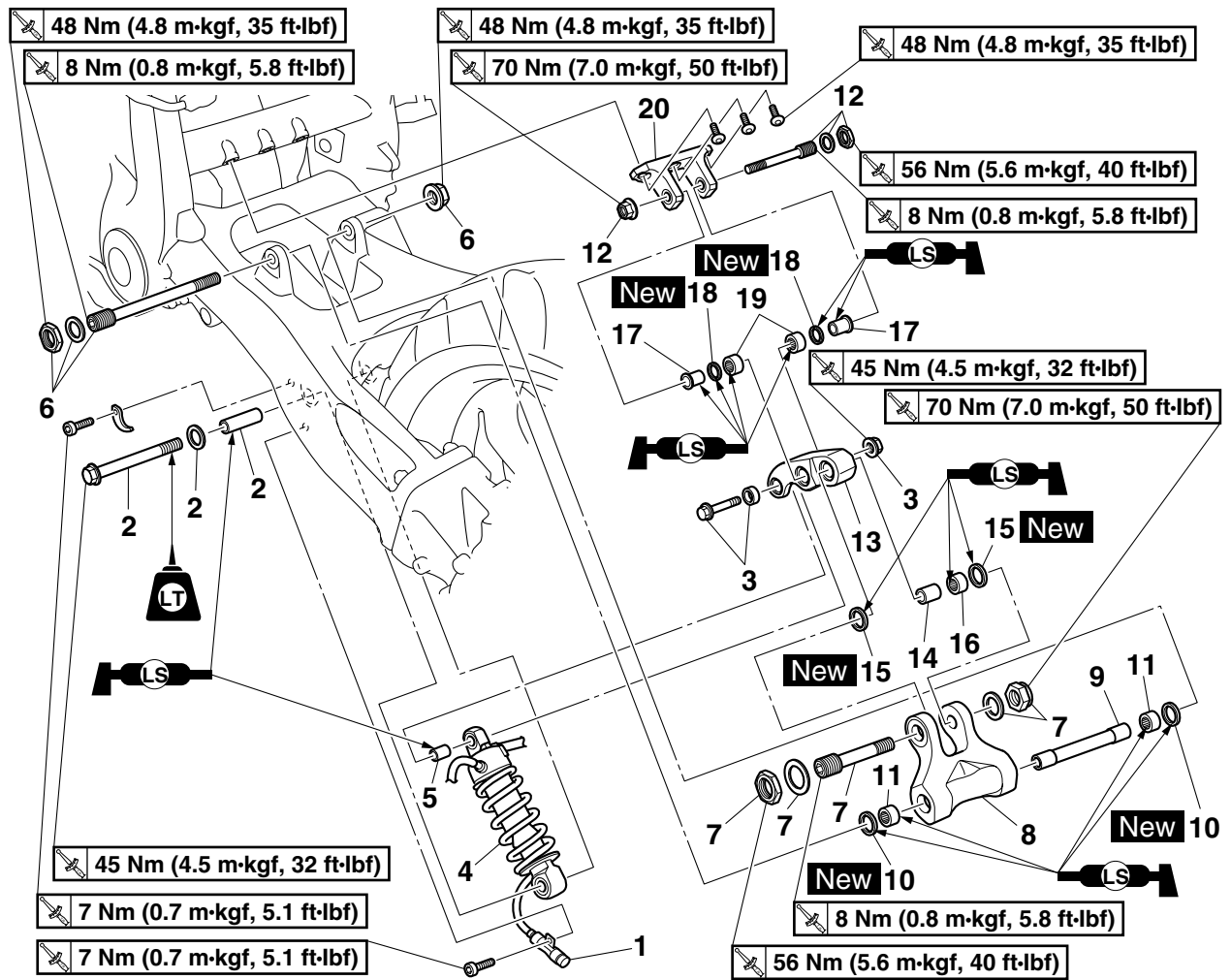

Order	Job/Parts to remove	Q'ty	Remarks
	Fuel tank		Refer to "FUEL TANK" on page 7-1.
	Mufflers/Exhaust pipe assembly		Refer to "ENGINE REMOVAL" on page 5-1.
1	Rebound damping adjusting knob	1	
2	Rear shock absorber assembly lower bolt/Washer/Spacer	1/1/1	
3	Rear shock absorber assembly upper nut/Bolt/Collar	1/1/1	
4	Rear shock absorber assembly	1	
5	Spacer	1	
6	Connecting arm and swingarm locknut/Washer/Nut/Bolt	1/1/1/1	
7	Connecting arm and relay arm locknut/Washer/Nut/Bolt	1/2/1/1	
8	Connecting arm	1	
9	Collar	1	
10	Oil seal	2	
11	Bearing	2	

REAR SHOCK ABSORBER ASSEMBLY

Removing the rear shock absorber assembly

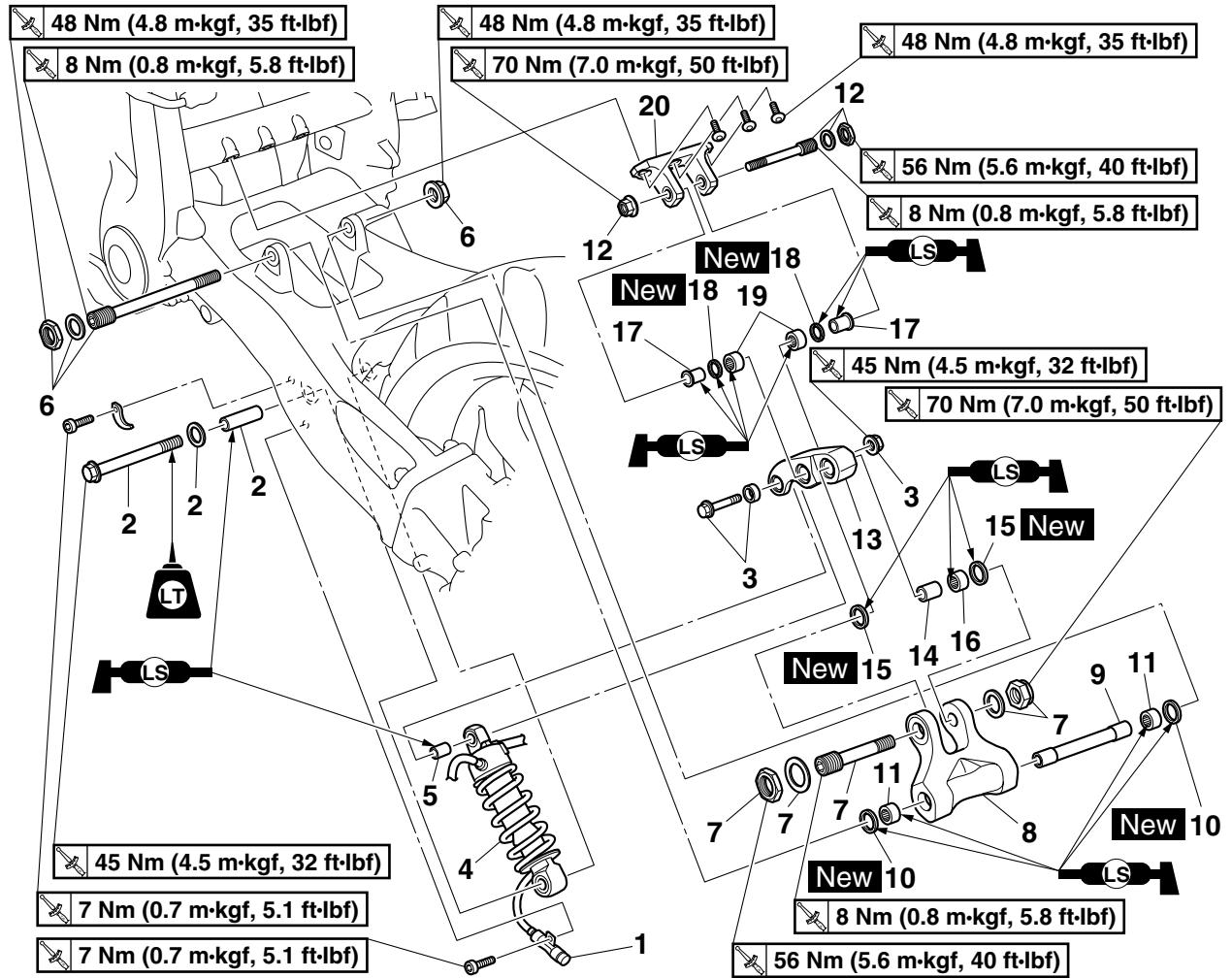

Order	Job/Parts to remove	Q'ty	Remarks
12	Relay arm and relay arm bracket locknut/Washer/Nut/Bolt	1/1/1/1	
13	Relay arm	1	
14	Spacer	1	
15	Oil seal	2	
16	Bearing	1	
17	Collar	2	
18	Oil seal	2	
19	Bearing	2	
20	Relay arm bracket	1	
			For installation, reverse the removal procedure.

REAR SHOCK ABSORBER ASSEMBLY

EAS23170

HANDLING THE REAR SHOCK ABSORBER AND GAS CYLINDER

EWA13750

WARNING

This rear shock absorber and gas cylinder contain highly compressed nitrogen gas. Before handling the rear shock absorber or gas cylinder, read and make sure you understand the following information. The manufacturer cannot be held responsible for property damage or personal injury that may result from improper handling of the rear shock absorber and gas cylinder.

- Do not tamper or attempt to open the rear shock absorber or gas cylinder.
- Do not subject the rear shock absorber or gas cylinder to an open flame or any other source of high heat. High heat can cause an explosion due to excessive gas pressure.
- Do not deform or damage the rear shock absorber or gas cylinder in any way. If the rear shock absorber, gas cylinder or both are damaged, damping performance will suffer.

EAS23190

DISPOSING OF A REAR SHOCK ABSORBER

1. Gas pressure must be released before disposing of a rear shock absorber. To release the gas pressure, drill a 2–3 mm (0.08–0.12 in) hole through the rear shock absorber at a point 45–55 mm (1.77–2.17 in) from its end as shown.

EWA13760

WARNING

Wear eye protection to prevent eye damage from released gas or metal chips.

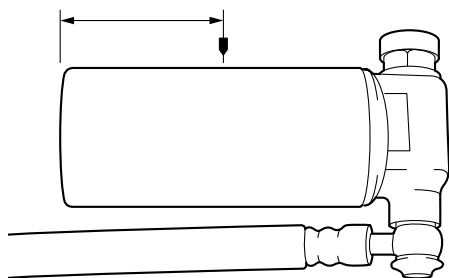

EAS23230

REMOVING THE REAR SHOCK ABSORBER ASSEMBLY

1. Stand the vehicle on a level surface.

EWA13120

WARNING

Securely support the vehicle so that there is no danger of it falling over.

TIP

Place the vehicle on a suitable stand so that the rear wheel is elevated.

2. Remove:

- Rear shock absorber assembly lower bolt
- Washer
- Spacer

TIP

While removing the rear shock absorber assembly lower bolt and spacer, hold the swingarm so that it does not drop down.

EAS23250

CHECKING THE REAR SHOCK ABSORBER ASSEMBLY AND GAS CYLINDER

1. Check:

- Rear shock absorber rod
Bends/damage → Replace the rear shock absorber assembly.
- Rear shock absorber
Gas leaks/oil leaks → Replace the rear shock absorber assembly.
- Spring
Damage/wear → Replace the rear shock absorber assembly.
- Gas cylinder
Damage/gas leaks → Replace.
- Bushings
Damage/wear → Replace the rear shock absorber assembly.
- Bolts
Bends/damage/wear → Replace.

EAS23260

CHECKING THE CONNECTING ARM AND RELAY ARM

1. Check:

- Connecting arm
Damage/wear → Replace.

2. Check:

- Bearings
Damage/pitting → Replace.

REAR SHOCK ABSORBER ASSEMBLY

TIP

- Hold the connecting arm and relay arm bolt so that it does not turn while tightening the connecting arm and relay arm nut.
- Hold the connecting arm and swingarm bolt so that it does not turn while tightening the connecting arm and swingarm nut.



Connecting arm and relay arm nut
70 Nm (7.0 m·kgf, 50 ft·lbf)
Connecting arm and swingarm nut
48 Nm (4.8 m·kgf, 35 ft·lbf)

- c. Tighten the connecting arm and relay arm and connecting arm and swingarm locknuts.



Connecting arm and relay arm locknut
56 Nm (5.6 m·kgf, 40 ft·lbf)
Connecting arm and swingarm locknut
48 Nm (4.8 m·kgf, 35 ft·lbf)

- d. Tighten the relay arm and relay arm bracket bolt.



Relay arm and relay arm bracket bolt
8 Nm (0.8 m·kgf, 5.8 ft·lbf)

- e. Tighten the relay arm and relay arm bracket nut.

TIP

Hold the relay arm and relay arm bracket bolt so that it does not turn while tightening the relay arm and relay arm bracket nut.



Relay arm and relay arm bracket nut
70 Nm (7.0 m·kgf, 50 ft·lbf)

- f. Tighten the relay arm and relay arm bracket locknut.



Relay arm and relay arm bracket locknut
56 Nm (5.6 m·kgf, 40 ft·lbf)

5. Install:

- Rear shock absorber assembly

TIP

When installing the rear shock absorber assembly, lift up the swingarm.

6. Tighten:

- Rear shock absorber assembly upper nut
- Rear shock absorber assembly lower bolt



Rear shock absorber assembly upper nut
45 Nm (4.5 m·kgf, 32 ft·lbf)
Rear shock absorber assembly lower bolt
45 Nm (4.5 m·kgf, 32 ft·lbf)
LOCTITE®



EAS23330

SWINGARM

Removing the swingarm

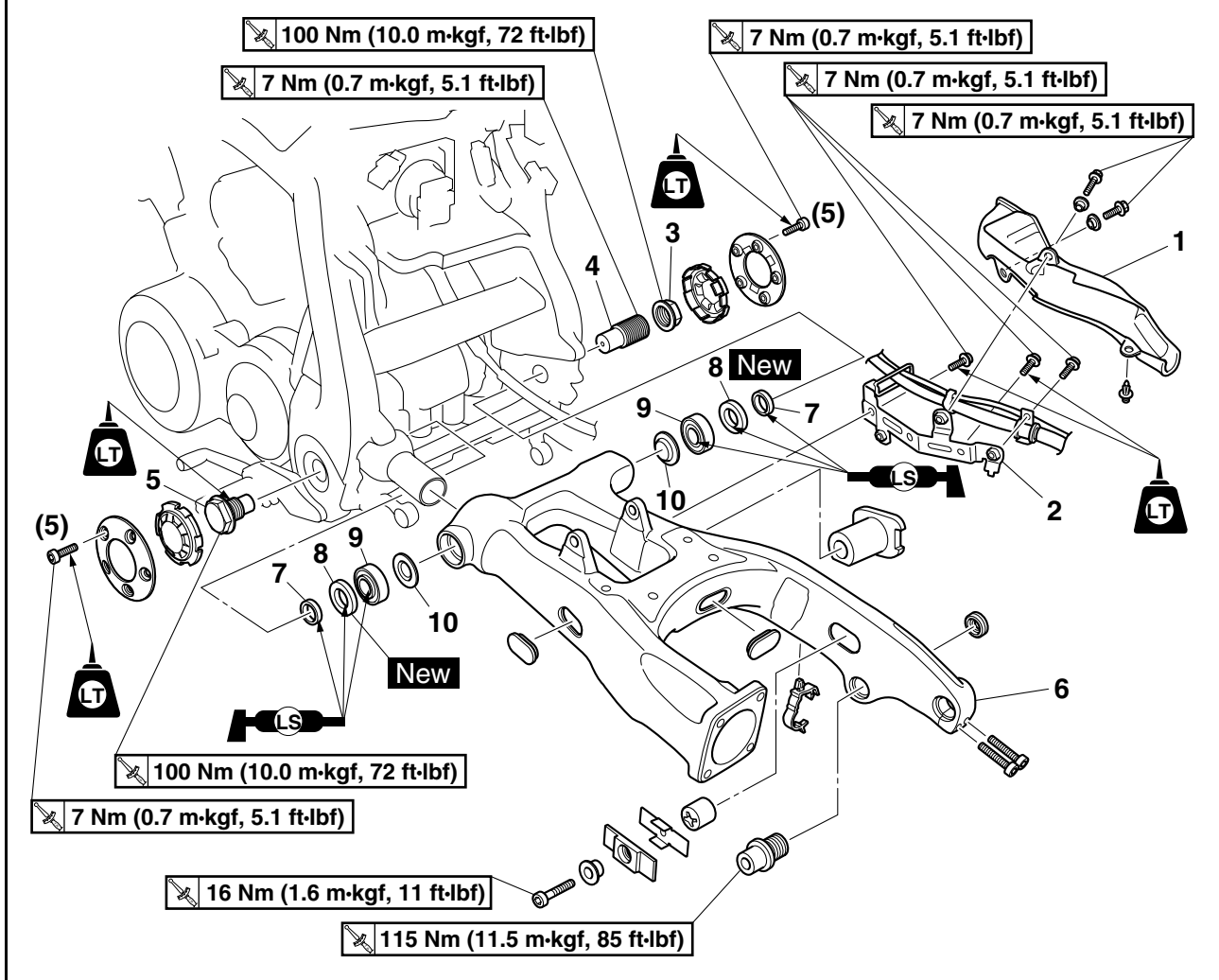

Order	Job/Parts to remove	Q'ty	Remarks
	Rear wheel		Refer to "REAR WHEEL" on page 4-20.
	Rear shock absorber assembly		Refer to "REAR SHOCK ABSORBER ASSEMBLY" on page 4-83.
	Final drive assembly		Refer to "SHAFT DRIVE" on page 4-91.
1	Brake hose cover	1	
2	Brake hose guide	1	
3	Pivot bolt locknut	1	
4	Right pivot bolt	1	
5	Left pivot bolt	1	
6	Swingarm	1	
7	Spacer	2	
8	Oil seal	2	
9	Bearing	2	
10	Plate	2	
			For installation, reverse the removal procedure.

EAS23350

REMOVING THE SWINGARM

1. Stand the vehicle on a level surface.

EWA13120



WARNING

Securely support the vehicle so that there is no danger of it falling over.

TIP

Place the vehicle on a suitable stand so that the rear wheel is elevated.

2. Measure:

- Swingarm side play
- Swingarm vertical movement

- a. Measure the tightening torque of the left pivot bolt, right pivot bolt, and pivot bolt locknut.



Left pivot bolt
100 Nm (10.0 m·kgf, 72 ft·lbf)
Right pivot bolt
7 Nm (0.7 m·kgf, 5.1 ft·lbf)
Pivot bolt locknut
100 Nm (10.0 m·kgf, 72 ft·lbf)

- b. Measure the swingarm side play "A" by moving the swingarm from side to side.
- c. If the swingarm side play is out of specification, check the spacers, bearings, plates, and oil seals.



Swingarm side play (at the end of the swingarm)
0 mm (0 in)

- d. Check the swingarm vertical movement "B" by moving the swingarm up and down. If swingarm vertical movement is not smooth or if there is binding, check the spacers, bearings, plates, and oil seals.

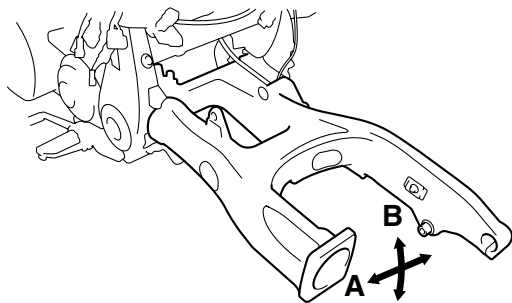

EAS23360

CHECKING THE SWINGARM

1. Check:
 - Swingarm
Bends/cracks/damage → Replace.
2. Check:
 - Left pivot bolt
 - Right pivot bolt
Bends/cracks/damage → Replace.
3. Wash:
 - Left pivot bolt
 - Right pivot bolt
 - Spacers
 - Bearings
 - Plates



Recommended cleaning solvent
Kerosene

4. Check:
 - Plates
 - Spacers
 - Oil seals
Damage/wear → Replace.
 - Bearings
Damage/pitting → Replace.

EAS23390

INSTALLING THE SWINGARM

1. Lubricate:
 - Bearings
 - Oil seals
 - Spacers



Recommended lubricant
Lithium-soap-based grease

2. Install:
 - Swingarm

- a. Temporarily install the left pivot bolt and right pivot bolt to hold the swingarm in place.
- b. Tighten the left pivot bolt.



Left pivot bolt
100 Nm (10.0 m·kgf, 72 ft·lbf)
LOCTITE®

- c. Thread the right pivot bolt into the swingarm until it makes contact with the spacer, and then tighten the pivot bolt to the specified torque.



Right pivot bolt
7 Nm (0.7 m·kgf, 5.1 ft·lbf)

d. Tighten the pivot bolt locknut.



Pivot bolt locknut
100 Nm (10.0 m·kgf, 72 ft·lbf)



EAS23551

SHAFT DRIVE

Removing the final drive assembly

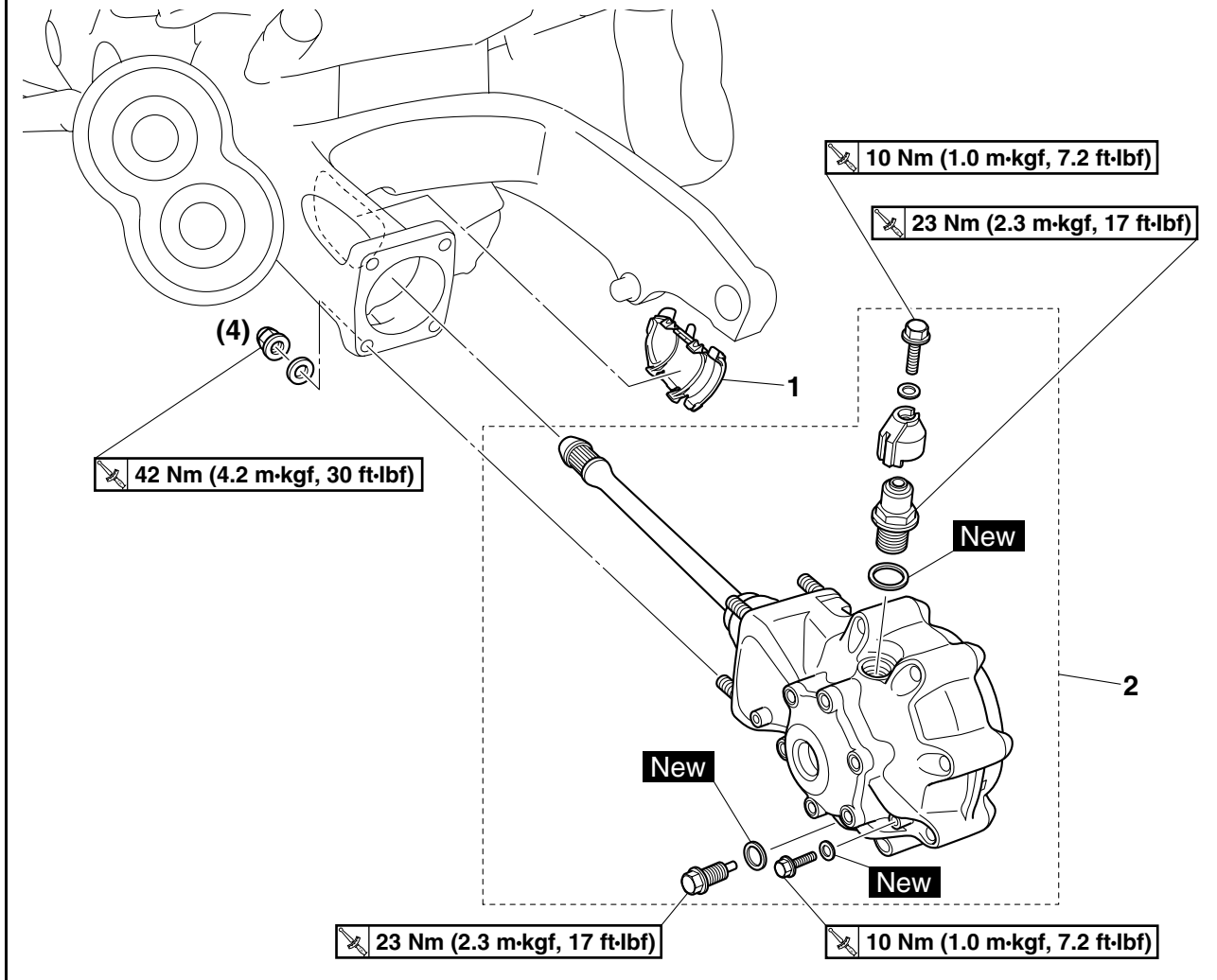

Order	Job/Parts to remove	Q'ty	Remarks
	Final gear oil		Drain. Refer to "CHANGING THE FINAL GEAR OIL" on page 3-26.
	Rear wheel		Refer to "REAR WHEEL" on page 4-20.
1	Swingarm inner panel	1	
2	Final drive assembly	1	
			For installation, reverse the removal procedure.

Disassembling the final drive assembly

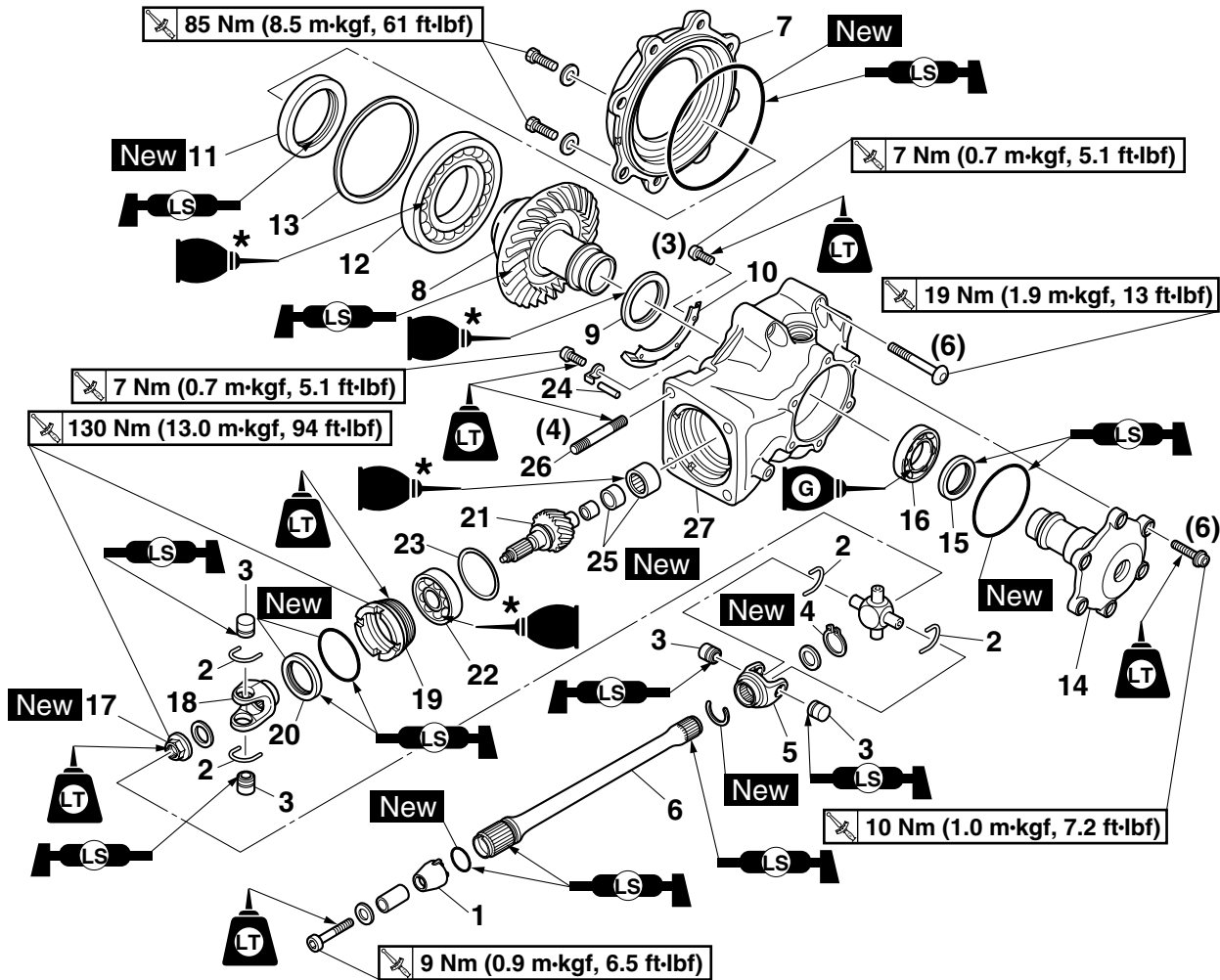

Order	Job/Parts to remove	Q'ty	Remarks
1	Drive shaft end cap	1	
2	Circlip	4	
3	Bearing	4	
4	Circlip	1	
5	Universal joint (final drive side)	1	
6	Drive shaft	1	
7	Ring gear bearing housing	1	
8	Ring gear	1	
9	Thrust washer	1	Refer to "ADJUSTING THE FINAL GEAR BACKLASH" on page 4-97 and "ALIGNING THE FINAL DRIVE PINION GEAR AND RING GEAR" on page 4-100.
10	Baffle plate	1	
11	Oil seal	1	
12	Bearing	1	
13	Ring gear shim		Refer to "ADJUSTING THE FINAL GEAR BACKLASH" on page 4-97 and "ALIGNING THE FINAL DRIVE PINION GEAR AND RING GEAR" on page 4-100.

Disassembling the final drive assembly

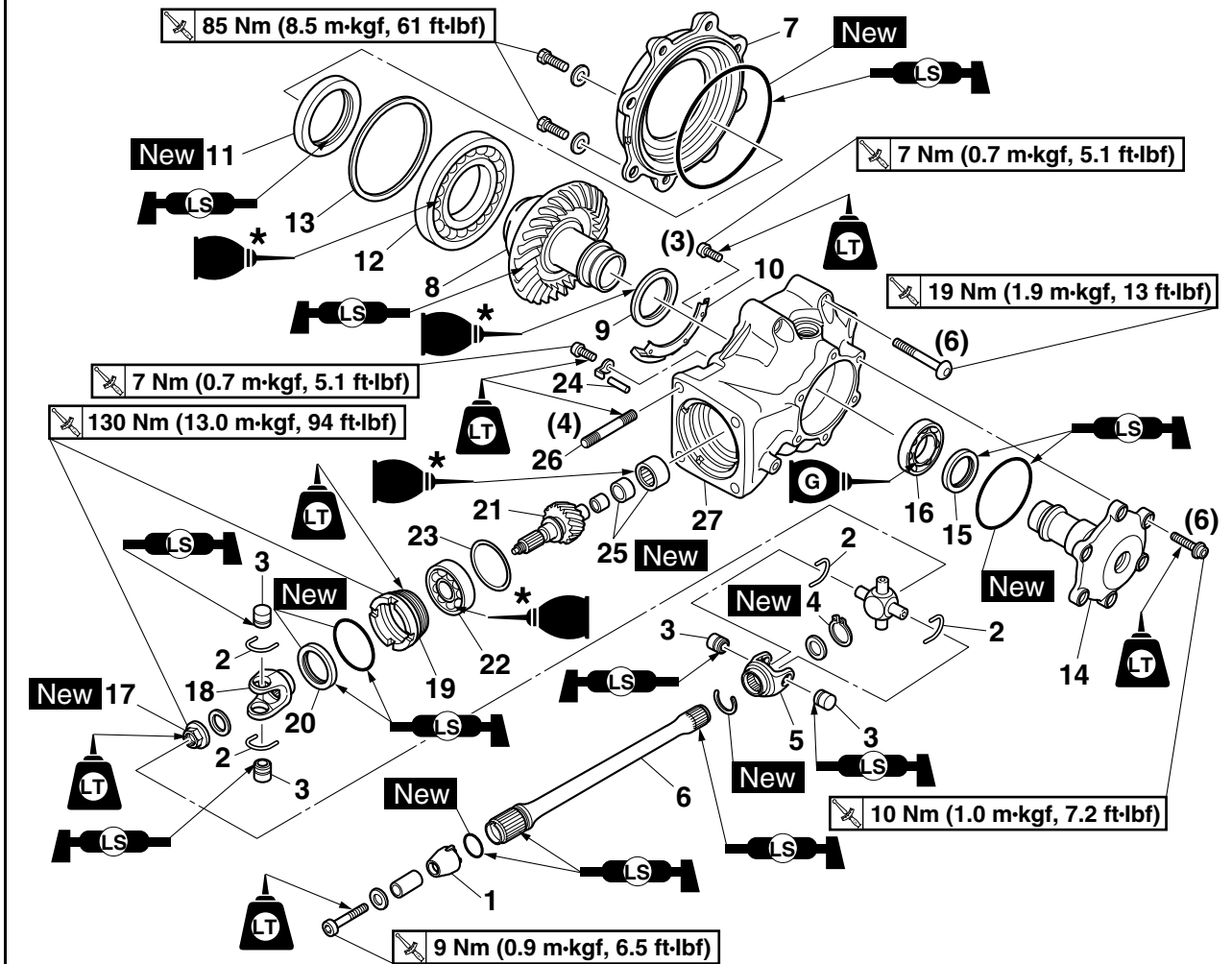

Order	Job/Parts to remove	Q'ty	Remarks
27	Final drive case	1	
			For assembly, reverse the disassembly procedure.

* Shaft drive gear oil (9079E-SH001-00)

EAS23560

TROUBLESHOOTING

Symptom	Possible cause
1. A pronounced hesitation or jerky movement during acceleration, deceleration or sustained speeds (not to be confused with engine surging or transmission-related movements). 2. A rolling “rumble” noticeable at low speeds, a high-pitched whine or a “clunk” from a shaft drive component, or from the vicinity of the shaft drive. 3. The shaft drive is locked up or no power is transmitted from the engine to the rear wheel.	A. Bearing damage B. Improper gear backlash C. Damaged gear teeth D. Broken drive shaft E. Broken gear teeth F. Seizure due to lack of lubrication G. Small foreign objects lodged between moving parts

TIP

Causes A, B, and C may be extremely difficult to diagnose. The symptoms are quite subtle and difficult to distinguish from normal operating noises. If there is reason to believe that these components are damaged, remove them and check them individually.

Inspection notes

- Investigate any unusual noises.



The following noises may indicate a mechanical defect:

- A rolling “rumble” during coasting, acceleration or deceleration (increases with the rear wheel speed, but does not increase with higher engine or transmission speeds)
Wheel bearing damage
- A whining noise that varies with acceleration and deceleration
Incorrect reassembly or too little gear backlash

EWA13780



WARNING

Insufficient gear backlash is extremely destructive to the gear teeth. If a test ride, following re-assembly, indicates these symptoms, stop riding immediately to minimize gear damage.

- A slight “clunk” evident at low speed operation (not to be confused with normal vehicle operation)
Broken gear teeth

EWA13790



WARNING

Stop riding immediately if broken gear teeth are suspected. This condition could result in the shaft drive assembly locking up, causing a loss of control and possible injury to the rider.



Troubleshooting chart

When causes (a) or (b) shown in the table at the beginning of the “TROUBLESHOOTING” section exist, check the following points.

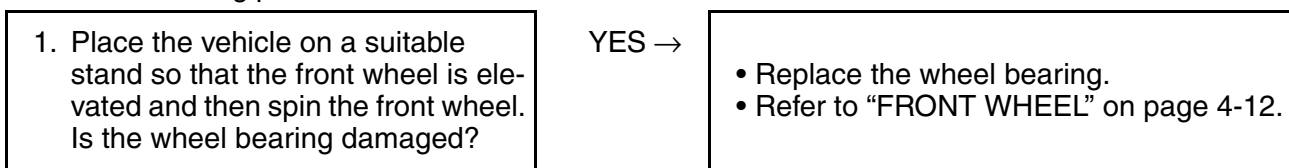

NO ↓

2. Place the vehicle on a suitable stand so that the rear wheel is elevated and then spin the rear wheel. Is the wheel bearing damaged?

YES ↓

3. Remove the rear wheel. Is the wheel bearing damaged?

NO ↓

Remove and check the drive shaft components.

NO →

Rear wheel bearings and shaft drive bearings are probably not damaged. Repeat the test or remove and check the components.

YES →

- Replace the rear wheel bearing(s).
- Refer to "REAR WHEEL" on page 4-20.

EAS23570

CHECKING THE FINAL GEAR OIL FOR CONTAMINATION AND CHECKING THE SHAFT DRIVE FOR LEAKS

1. Drain:

- Final gear oil (from the final gear case)
Refer to "CHANGING THE FINAL GEAR OIL" on page 3-26.

2. Check:

- Final gear oil
Large amount of metal particles → Check for bearing seizure.

TIP

A small amount of metal particles in the final gear oil is normal.

3. Check:

- Final drive assembly (for oil leaks)



- Thoroughly clean the entire vehicle and then completely dry it.
- Apply a leak-locating compound or dry powder spray to the final drive assembly.
- Test ride the vehicle long enough to locate a leak.

Oil leak → Repair or replace the faulty part(s).

TIP

- What may appear to be an oil leak on a new or fairly new vehicle, may result from the application of a rust preventive coating or excessive seal lubrication.
- Always clean the vehicle and recheck the area where the leak is thought to originate from.

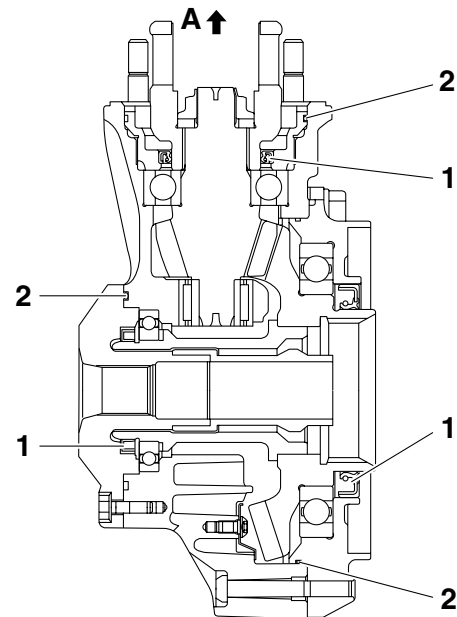

1. Oil seal
2. O-ring
- A. Forward



EAS23581

MEASURING THE FINAL GEAR BACKLASH

TIP

Before measuring the final gear backlash, remove the baffle plate from the final drive case.

1. Secure the final drive assembly in a vise.
2. Remove:
 - Final gear oil drain bolt
3. Drain:
 - Final gear oil (from the final drive assembly)

4. Measure:

- Final gear backlash
Out of specification → Adjust.



Final gear backlash
0.1–0.2 mm (0.004–0.008 in)

- a. Install the ring gear fix bolt “1” into the final gear oil drain hole.



Ring gear fix bolt (M14)
90890-01548
YM-01548

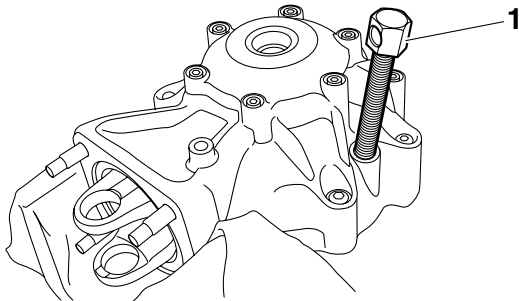

- b. Finger tighten the ring gear fix bolt until it stops the ring gear from moving.

TIP

Do not overtighten the ring gear fix bolt.

- c. Attach the dial gauge “2” to a fixed surface and position the dial gauge plunger so that it contacts edge of the universal joint yoke “3” as shown.

TIP

Make sure the dial gauge plunger contacts the measuring point on the centerline of the yoke bearing hole as shown.

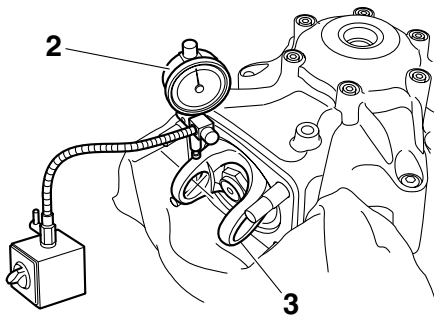

- d. Gently rotate the final drive pinion gear from engagement to engagement.
e. Record the reading on the dial gauge.
f. Remove the dial gauge, and ring gear fix bolt.
g. Rotate the final drive pinion gear 90°.

- h. Reinstall the ring gear fix bolt, and dial gauge.
i. Repeat steps (d) to (h) three more times (for a total of four measurements).
j. If any of the readings are over specification, adjust the final gear backlash.

EAS23591

ADJUSTING THE FINAL GEAR BACKLASH

1. Remove:

- Ring gear bearing housing bolts (M12) “1”
- Final drive case bolts (M8) “2”

TIP

Working in a crisscross pattern, loosen each bolt 1/4 of a turn. After all of the bolts are fully loosened, remove them.

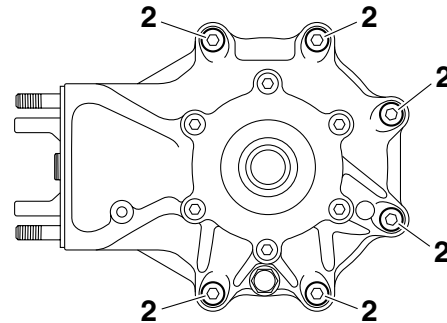
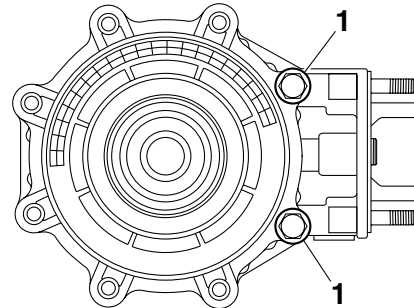

2. Remove:

- Ring gear bearing housing “1”
- Ring gear “2”
- Ring gear shim(s) “3”
- Thrust washer “4”

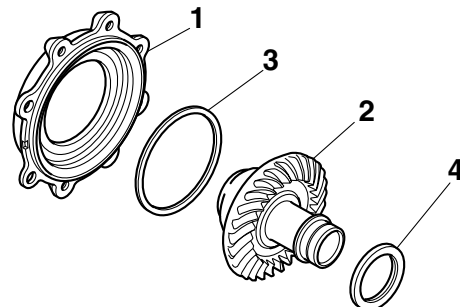

- Install the final drive case stud bolts so that the specified installed length “a” is obtained.

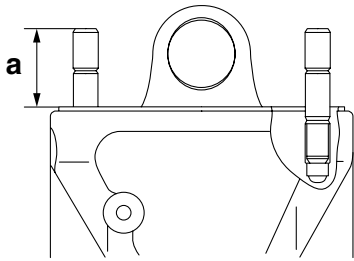

a. 30–31 mm (1.18–1.22 in)

EAS23640

ALIGNING THE FINAL DRIVE PINION GEAR AND RING GEAR

TIP

Aligning the final drive pinion gear and ring gear is necessary when any of the following parts are replaced:

- Final drive case
- Ring gear bearing housing
- Any bearing

1. Select:

- Final drive pinion gear shim(s) “1”
- Ring gear shim(s) “2”



- a. Position the final drive pinion gear shim(s) and the ring gear with shim(s). Calculate the respective thicknesses from information marked on the final drive case, ring gear bearing housing, and ring gear.

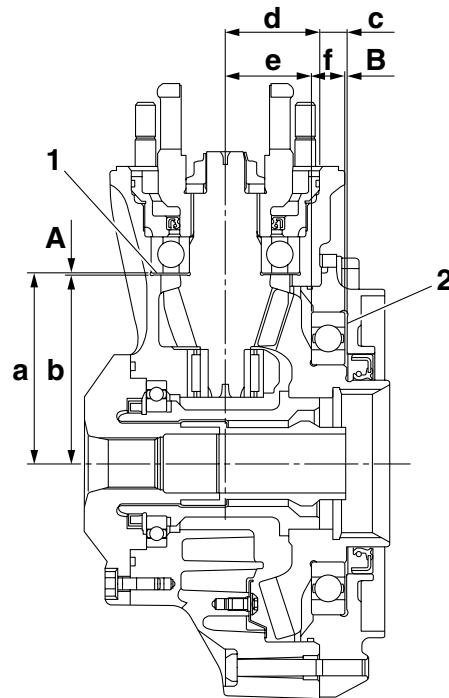

- b. To find final drive pinion gear shim thickness “A”, use the following formula:

Final drive pinion gear shim thickness $A = a - b - 0.2$

Where:

a = 92

b = a numeral on the final drive case, to be divided by 100 and added to “91”.

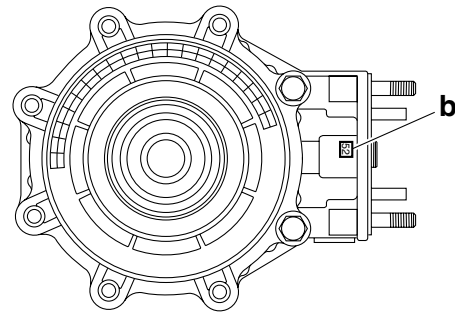

Example:

If the final drive case is marked “52”:

$$\begin{aligned}
 A &= 92 - (91 + 52/100) - 0.2 \\
 &= 92 - (91 + 0.52) - 0.2 \\
 &= 92 - 91.52 - 0.2 \\
 &= 0.28
 \end{aligned}$$

Therefore, the calculated final drive pinion gear shim thickness is 0.28 mm. Shim sizes are supplied in the following thicknesses.



Final drive pinion gear shims
Thickness (mm)
0.30 0.40 0.50

Since the final drive pinion gear shims are only available in 0.10 mm increments, round off to the hundredths digit.

Hundredth	Rounded value
0, 1, 2	0
3, 4, 5, 6, 7	5
8, 9	10

In the example above, the calculated final drive pinion gear shim thickness is 0.28 mm. The chart instructs you to round off the 8 to 10. Thus, you should use a 0.30 mm final drive pinion gear shim.

c. To find ring gear shim thickness “B”, use the following formula:

Ring gear shim thickness
 $B = c + d - e - f - 0.1$

Where:

c = a numeral usually on the ring gear bearing housing, to be divided by 100 and added to “11.9”.

d = a numeral on the final drive case, to be divided by 100 and added to “45”.

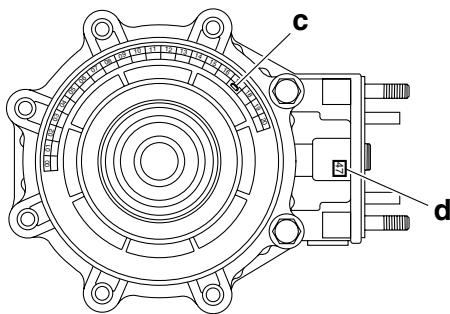

e = a numeral (positive or negative) on the ring gear, to be divided by 100 and added to “41”.

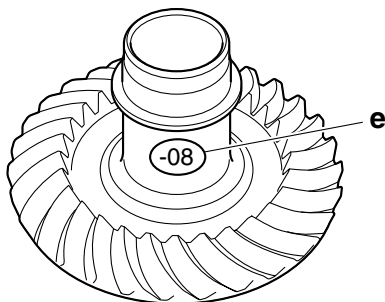

f = the ring gear bearing thickness constant.



Ring gear bearing thickness
15.90 mm (0.63 in)

Example:

If the ring gear bearing housing is marked “17”, the final drive case is marked “47”, the ring gear is marked “- 08”, and “f” is 15.90:

$$\begin{aligned}
 B &= (11.9 + 17/100) + (45 + 47/100) - (41 - 8/100) - 15.90 - 0.1 \\
 &= (11.9 + 0.17) + (45 + 0.47) - (41 - 0.08) - 15.90 - 0.1 \\
 &= 12.07 + 45.47 - 40.92 - 15.90 - 0.1 \\
 &= 0.62
 \end{aligned}$$

Therefore, the calculated ring gear shim thickness is 0.62 mm.

Shim sizes are supplied in the following thicknesses.



Ring gear shims
Thickness (mm)
0.25 0.30 0.40 0.50

Since the ring gear shims are only available in 0.10 mm increments, round off the hundredths digit.

Hundredth	Rounded value
0, 1, 2	0
3, 4, 5, 6, 7	5
8, 9	10

In the example above, the calculated ring gear shim thickness is 0.62 mm. The chart instructs you to round off the 2 to 0. Thus, you should use a 0.60 mm ring gear shim.

2. Install:

- Shims (as calculated)
- Final drive pinion gear
- Bearing retainer (with the bearing retainer wrench “1”)



Bearing retainer
130 Nm (13.0 m·kgf, 94 ft·lbf)
LOCTITE®

- e. Measure the width of the flattened Plasti-gauge® “1”.



Ring-gear-to-thrust-washer clearance
0.15–0.25 mm (0.006–0.010 in)

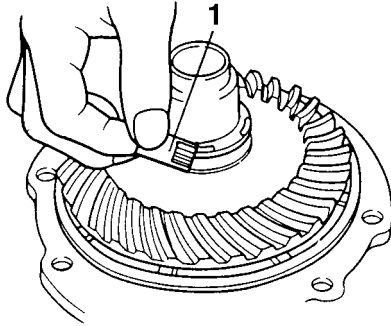

- f. If the ring-gear-to-thrust-washer clearance is within specification, install the ring gear bearing housing (along with the ring gear).
g. If the ring-gear-to-thrust-washer clearance is out of specification, select the correct thrust washer as follows.
h. Select the suitable thrust washer from the following chart.



Thrust washers
Thickness (mm)
1.2 1.4 1.6 1.8 2.0

- i. Repeat the measurement steps until the ring-gear-to-thrust-washer clearance is within the specified limits.



Ring-gear-to-thrust-washer clearance
0.15–0.25 mm (0.006–0.010 in)

EAS23650

CHECKING THE DRIVE SHAFT

1. Check:
- Drive shaft splines
Damage/wear → Replace the drive shaft.

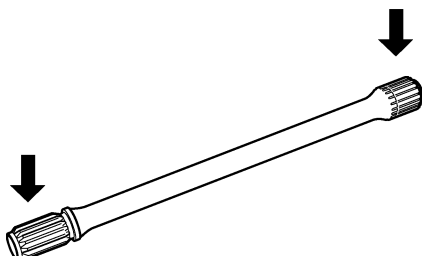

EAS2S31030

INSTALLING THE FINAL DRIVE ASSEMBLY

1. Install:
 - Drive shaft
(to the universal joint)
2. Install:
 - Universal joint (final drive side)



- a. Fit the universal joint into the yoke.
- b. Apply lithium-soap-based grease to the bearings.
- c. Install the bearing “1” into the yoke.

ECA2S31033

NOTICE

Check each bearing. The needle bearings can easily fall out of their races. Slide the yoke back and forth on the bearings; the yoke will not go all the way onto a bearing if a needle is out of place.

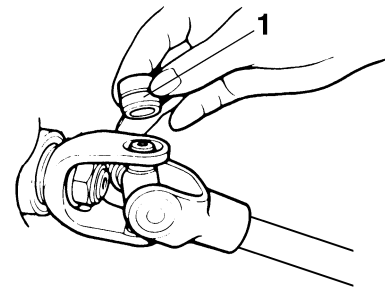

- d. Press each bearing into the yoke using a suitable socket.

TIP

The bearing must be inserted far enough into the yoke so that the circlip can be installed.

- e. Install the circlips “2” into the groove of each bearing.

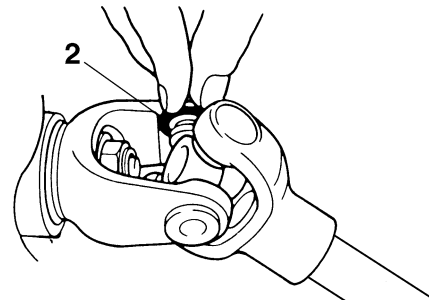

3. Check:
 - Universal joint operation
Rough operation → Replace the universal joint or bearing.

TIP

Lift the universal joint "1" and make sure that it falls freely when released.

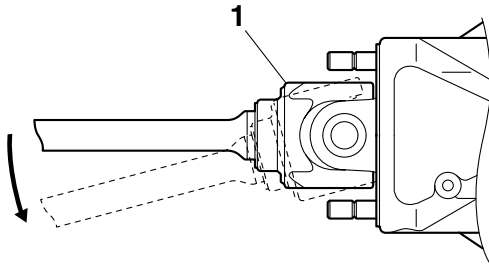

4. Install:

- Final drive assembly

TIP

Align the wide spline "b" on the drive shaft with the wide groove "a" in the universal joint (middle gear side).

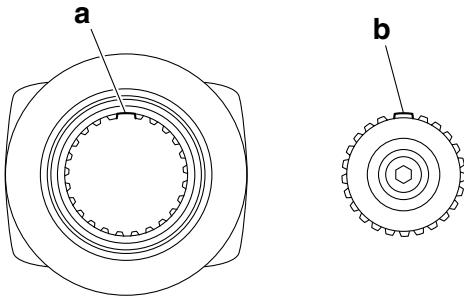

5. Tighten:

- Final drive assembly nut



Final drive assembly nut
42 Nm (4.2 m·kgf, 30 ft·lbf)

6. Install:

- Swingarm inner panel

TIP

- Fit the projection on the front of the swingarm inner panel into the swingarm, and then install the panel.
- Make sure that the projections "a" on the swingarm inner panel are securely fitted into the swingarm.

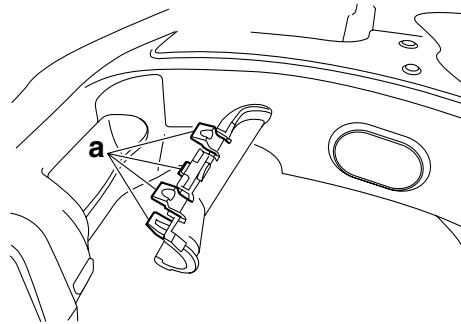

7. Install:

- Rear wheel
Refer to "REAR WHEEL" on page 4-20.

8. Fill:

- Final gear case
Refer to "CHECKING THE ENGINE OIL LEVEL" on page 3-10.

ENGINE

ENGINE REMOVAL	5-1
INSTALLING THE ENGINE.....	5-7
INSTALLING THE EXUP CABLES	5-8
CAMSHAFTS	5-9
REMOVING THE CAMSHAFTS.....	5-13
CHECKING THE CAMSHAFTS	5-14
CHECKING THE CAMSHAFT SPROCKETS	5-15
CHECKING THE CAMSHAFT GEARS	5-16
CHECKING THE DECOMPRESSION SYSTEM.....	5-16
CHECKING THE TIMING CHAIN GUIDES.....	5-16
CHECKING THE TIMING CHAIN TENSIONERS	5-16
INSTALLING THE CAMSHAFTS	5-17
CYLINDER HEADS	5-26
REMOVING THE CYLINDER HEADS	5-27
CHECKING THE CYLINDER HEADS.....	5-27
INSTALLING THE CYLINDER HEADS.....	5-27
VALVES AND VALVE SPRINGS	5-29
REMOVING THE VALVES.....	5-30
CHECKING THE VALVES AND VALVE GUIDES	5-30
CHECKING THE VALVE SEATS	5-32
CHECKING THE VALVE SPRINGS.....	5-34
CHECKING THE VALVE LIFTERS.....	5-34
INSTALLING THE VALVES	5-34
GENERATOR AND STARTER CLUTCH	5-37
REMOVING THE GENERATOR.....	5-40
REMOVING THE STARTER CLUTCH	5-40
CHECKING THE STARTER CLUTCH	5-40
INSTALLING THE STARTER CLUTCH	5-41
INSTALLING THE GENERATOR.....	5-41
ELECTRIC STARTER	5-44
CHECKING THE STARTER MOTOR	5-46
ASSEMBLING THE STARTER MOTOR.....	5-47

CLUTCH	5-48
REMOVING THE CLUTCH	5-56
CHECKING THE FRICTION PLATES.....	5-56
CHECKING THE CLUTCH PLATES	5-57
CHECKING THE CLUTCH SPRING PLATE.....	5-58
CHECKING THE CLUTCH HOUSING	5-58
CHECKING THE CLUTCH BOSS.....	5-58
CHECKING THE PRESSURE PLATE	5-58
CHECKING THE CLUTCH PUSH RODS	5-58
CHECKING THE PRIMARY DRIVEN GEAR	5-58
INSTALLING THE CLUTCH.....	5-59
DISASSEMBLING THE CLUTCH MASTER CYLINDER	5-60
CHECKING THE CLUTCH MASTER CYLINDER.....	5-61
ASSEMBLING THE CLUTCH MASTER CYLINDER	5-61
INSTALLING THE CLUTCH MASTER CYLINDER.....	5-61
REMOVING THE CLUTCH RELEASE CYLINDER	5-62
CHECKING THE CLUTCH RELEASE CYLINDER	5-62
ASSEMBLING THE CLUTCH RELEASE CYLINDER.....	5-63
INSTALLING THE CLUTCH RELEASE CYLINDER	5-63
SHIFT SHAFT	5-65
CHECKING THE SHIFT SHAFT	5-67
CHECKING THE STOPPER LEVER	5-67
INSTALLING THE SHIFT SHAFT	5-67
OIL PUMP	5-68
REMOVING THE OIL PAN.....	5-71
CHECKING THE OIL PUMP	5-71
CHECKING THE RELIEF VALVE	5-71
CHECKING THE OIL PIPE 2	5-72
CHECKING THE OIL STRAINER	5-72
ASSEMBLING THE OIL PUMP	5-72
INSTALLING THE OIL PUMP	5-72
INSTALLING THE OIL PAN	5-72
CRANKCASE	5-73
DISASSEMBLING THE CRANKCASE.....	5-76
CHECKING THE CRANKCASE	5-76
CHECKING THE OIL PIPE 3	5-76
CHECKING THE TIMING CHAIN GUIDE ASSEMBLY	5-77
CHECKING THE OIL NOZZLES	5-77
ASSEMBLING THE CRANKCASE.....	5-77
CONNECTING RODS AND PISTONS	5-81
REMOVING THE CONNECTING RODS AND PISTONS.....	5-82
CHECKING THE OIL NOZZLES	5-82
CHECKING THE CYLINDERS AND PISTONS	5-82
CHECKING THE PISTON RINGS.....	5-83
CHECKING THE PISTON PINS.....	5-84
CHECKING THE CONNECTING RODS.....	5-85
INSTALLING THE CONNECTING RODS AND PISTONS	5-88

CRANKSHAFT AND BALANCER	5-92
REMOVING THE BALANCER SHAFT JOURNAL BEARINGS	5-93
REMOVING THE CRANKSHAFT JOURNAL BEARINGS	5-93
CHECKING THE TIMING CHAINS	5-93
CHECKING THE CRANKSHAFT	5-93
CHECKING THE BALANCER	5-95
INSTALLING THE CRANKSHAFT	5-96
INSTALLING THE BALANCER SHAFT	5-97
TRANSMISSION	5-98
CHECKING THE SHIFT FORKS.....	5-102
CHECKING THE SHIFT DRUM ASSEMBLY.....	5-102
CHECKING THE TRANSMISSION	5-102
ASSEMBLING THE MAIN AXLE AND DRIVE AXLE	5-103
INSTALLING THE TRANSMISSION	5-104
MIDDLE GEAR	5-105
REMOVING THE MIDDLE DRIVEN PINION GEAR ASSEMBLY.....	5-109
DISASSEMBLING THE MIDDLE DRIVEN PINION GEAR ASSEMBLY	5-109
REMOVING THE MIDDLE DRIVE PINION GEAR ASSEMBLY	5-109
DISASSEMBLING THE MIDDLE DRIVE PINION GEAR ASSEMBLY	5-109
CHECKING THE MIDDLE DRIVEN PINION GEAR ASSEMBLY	5-110
CHECKING THE MIDDLE DRIVE PINION GEAR ASSEMBLY	5-110
ASSEMBLING THE MIDDLE DRIVE PINION GEAR ASSEMBLY	5-110
INSTALLING THE MIDDLE DRIVE PINION GEAR ASSEMBLY	5-110
ASSEMBLING THE MIDDLE DRIVEN PINION GEAR ASSEMBLY	5-111
INSTALLING THE MIDDLE DRIVEN PINION GEAR ASSEMBLY	5-112
MEASURING THE MIDDLE GEAR BACKLASH.....	5-113
ADJUSTING THE MIDDLE GEAR BACKLASH	5-113
ALIGNING THE MIDDLE GEAR	5-114

EAS23711

ENGINE REMOVAL

Removing the exhaust chamber and exhaust pipes

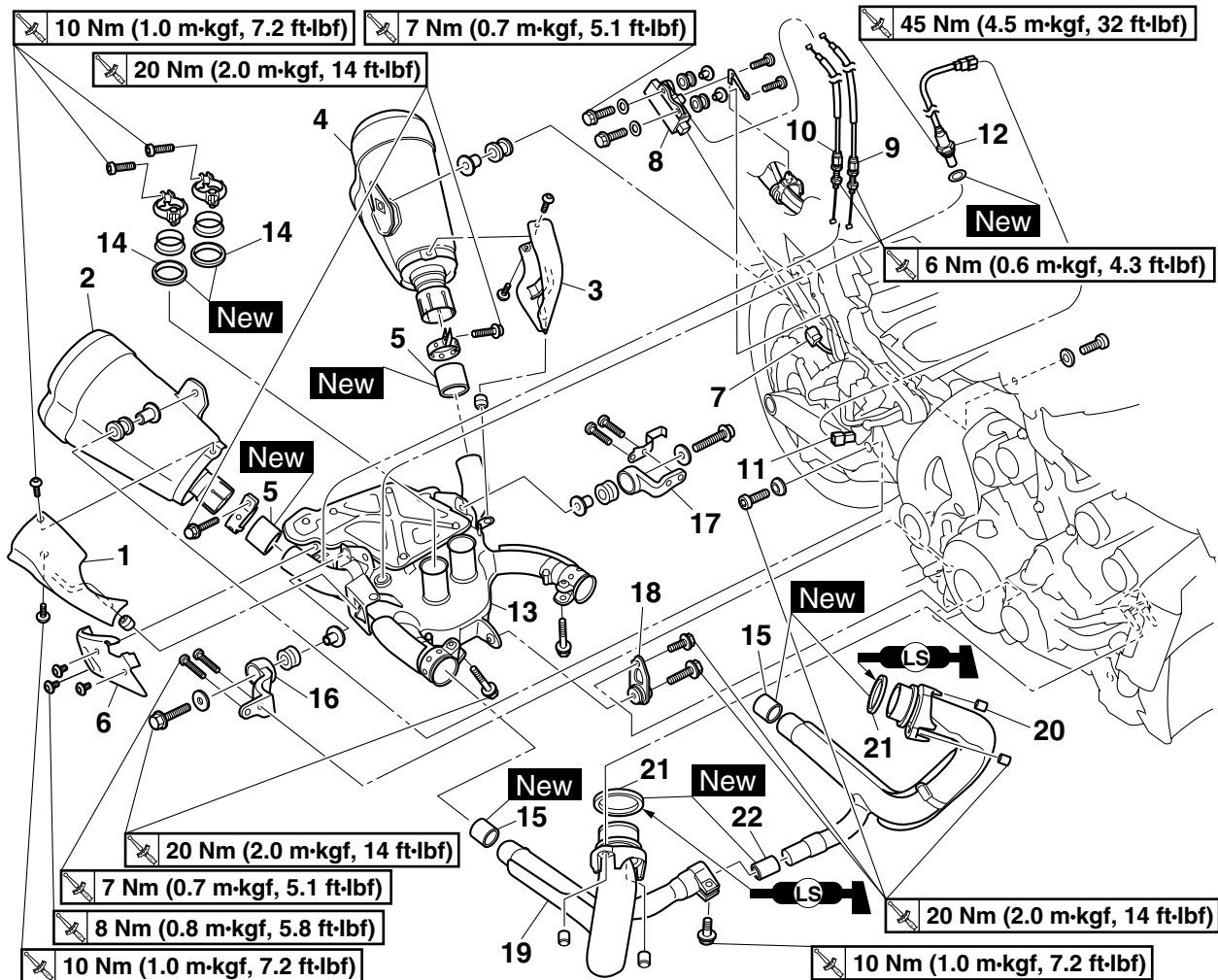

Order	Job/Parts to remove	Q'ty	Remarks
	Rear fender		Refer to "GENERAL CHASSIS" on page 4-1.
1	Right-muffler protector	1	
2	Right muffler	1	
3	Left-muffler protector	1	
4	Left muffler	1	
5	Gasket	2	
6	EXUP valve pulley cover	1	
7	EXUP servo motor coupler	1	Disconnect.
8	EXUP servo motor	1	
9	EXUP cable 1	1	Black adjusting bolt
10	EXUP cable 2	1	
11	O ₂ sensor coupler	1	Disconnect.
12	O ₂ sensor	1	
13	Exhaust chamber	1	
14	Gasket	2	

Removing the exhaust chamber and exhaust pipes

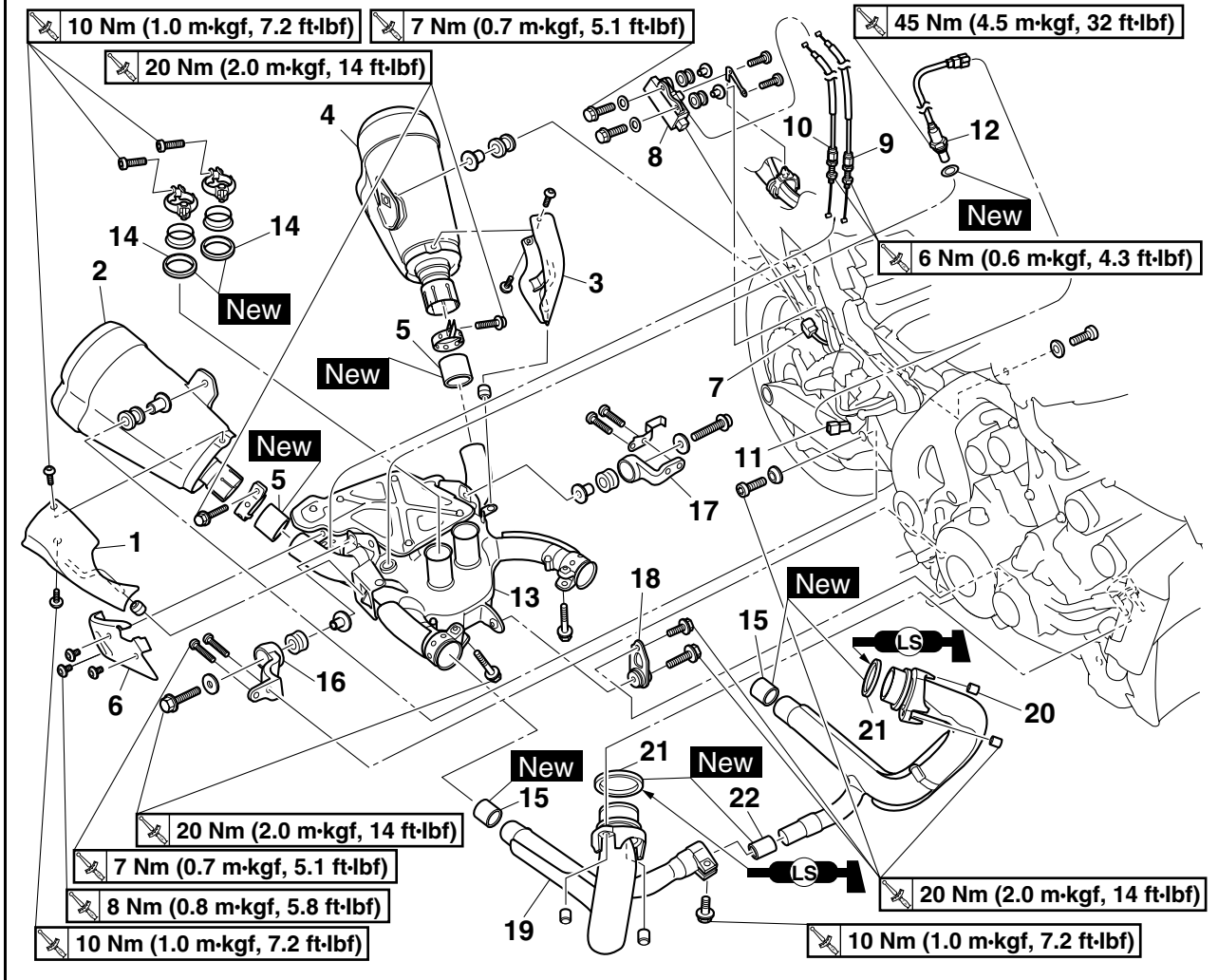

Order	Job/Parts to remove	Q'ty	Remarks
15	Gasket	2	
16	Exhaust chamber bracket (right side)	1	
17	Exhaust chamber bracket (left side)	1	
18	Exhaust chamber bracket (front side)	1	
19	Right front exhaust pipe	1	
20	Left front exhaust pipe	1	
21	Gasket	2	
22	Gasket	1	
			For installation, reverse the removal procedure.

Disconnecting the leads and hose

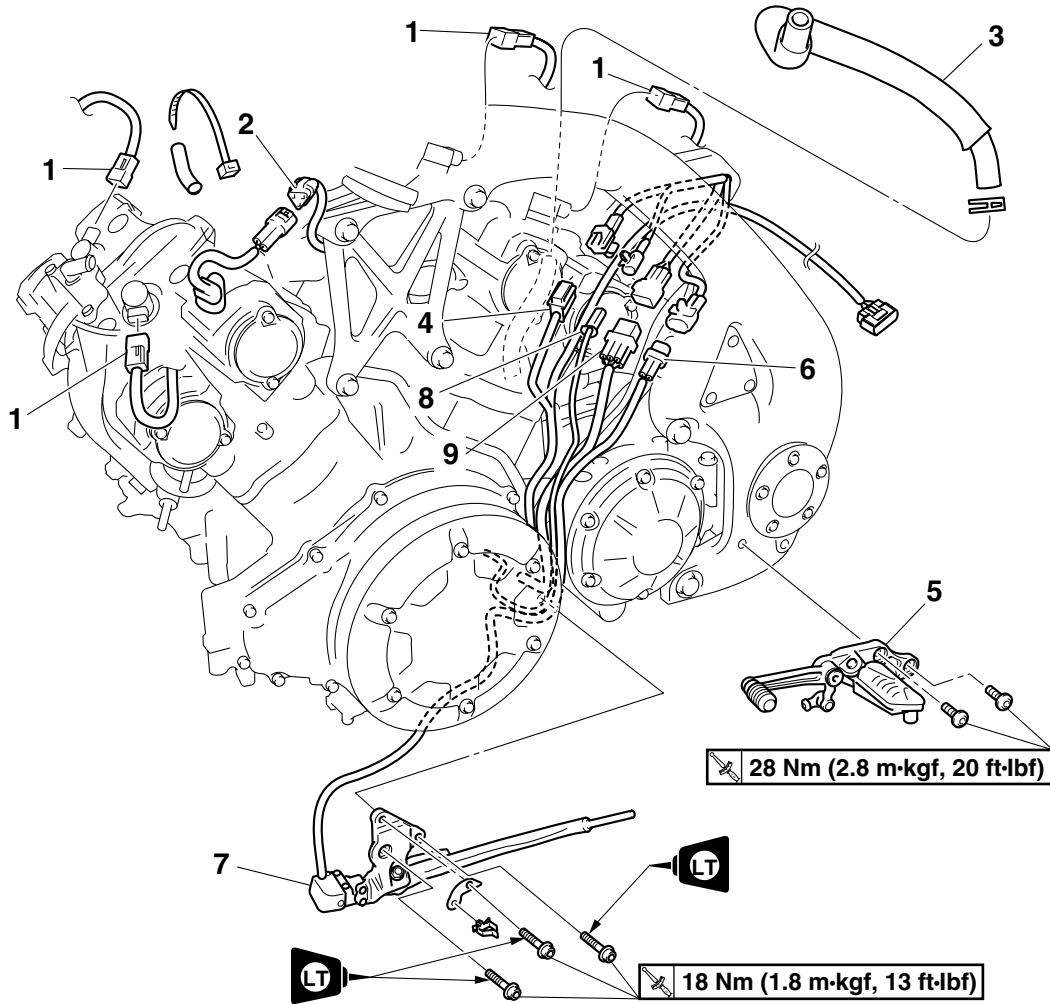

Order	Job/Parts to remove	Q'ty	Remarks
	Right rider footrest assembly		Refer to "REAR BRAKE" on page 4-41.
	Drive shaft		Refer to "SHAFT DRIVE" on page 4-91.
	Shift arm		Refer to "SHIFT SHAFT" on page 5-65.
	Clutch pipe		Refer to "CLUTCH" on page 5-48.
	Starter motor assembly		Refer to "ELECTRIC STARTER" on page 5-44.
	Fuel tank		Refer to "FUEL TANK" on page 7-1.
	Throttle bodies		Refer to "THROTTLE BODIES" on page 7-11.
	Air induction system hoses		Refer to "AIR INDUCTION SYSTEM" on page 7-19.
	Thermostat inlet pipes		Refer to "THERMOSTAT" on page 6-7.
	Radiator assembly		Refer to "RADIATORS" on page 6-1.
	Water pump outlet pipe/Water pump inlet pipe		Refer to "WATER PUMP" on page 6-11.
	Oil cooler adapter		Refer to "OIL COOLER" on page 6-5.
1	Ignition coil coupler	4	Disconnect.
2	Cylinder identification sensor coupler	1	Disconnect.
3	Crankcase breather hose	1	

ENGINE REMOVAL

Disconnecting the leads and hose

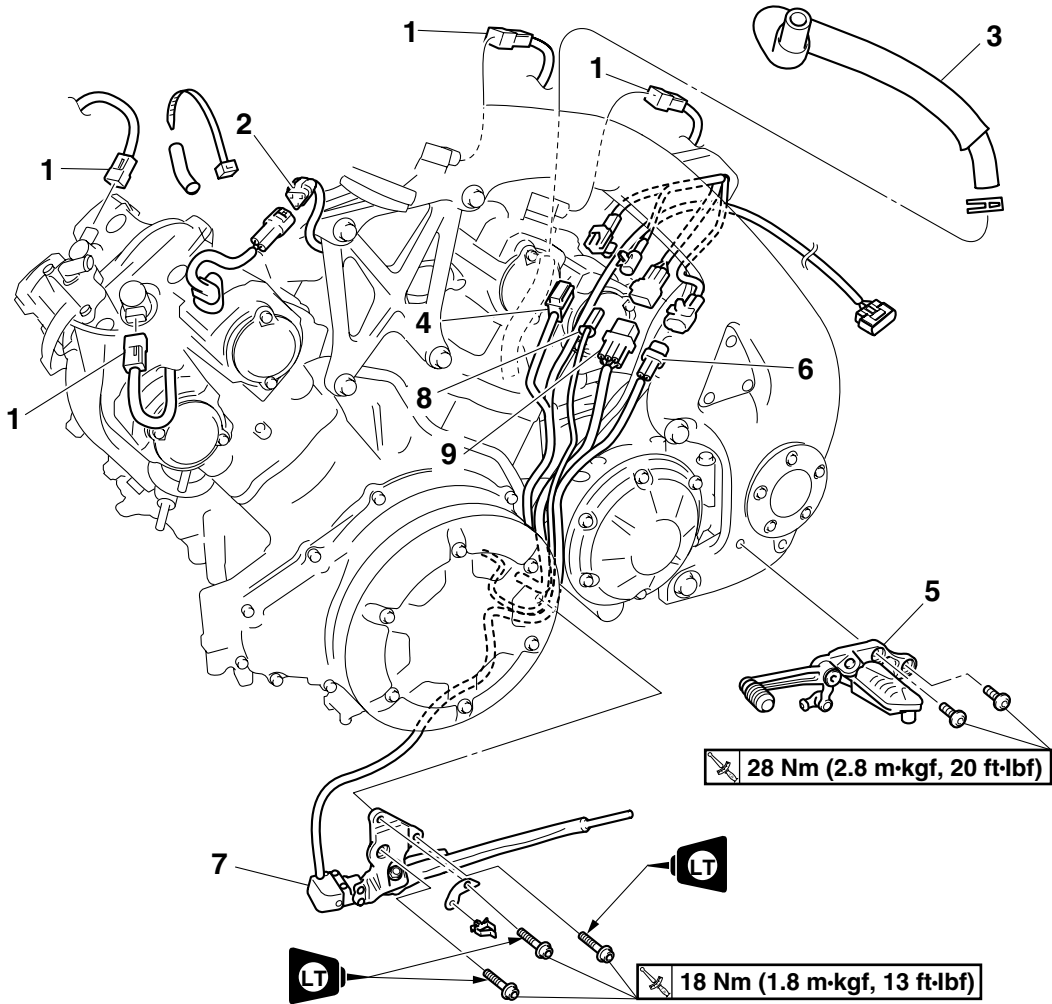

Order	Job/Parts to remove	Q'ty	Remarks
4	Crankshaft position sensor coupler	1	Disconnect.
5	Left rider footrest assembly	1	
6	Sidestand switch coupler	1	Disconnect.
7	Sidestand	1	
8	Oil level switch coupler	1	Disconnect.
9	Gear position switch coupler	1	Disconnect.
			For installation, reverse the removal procedure.

ENGINE REMOVAL

Removing the engine

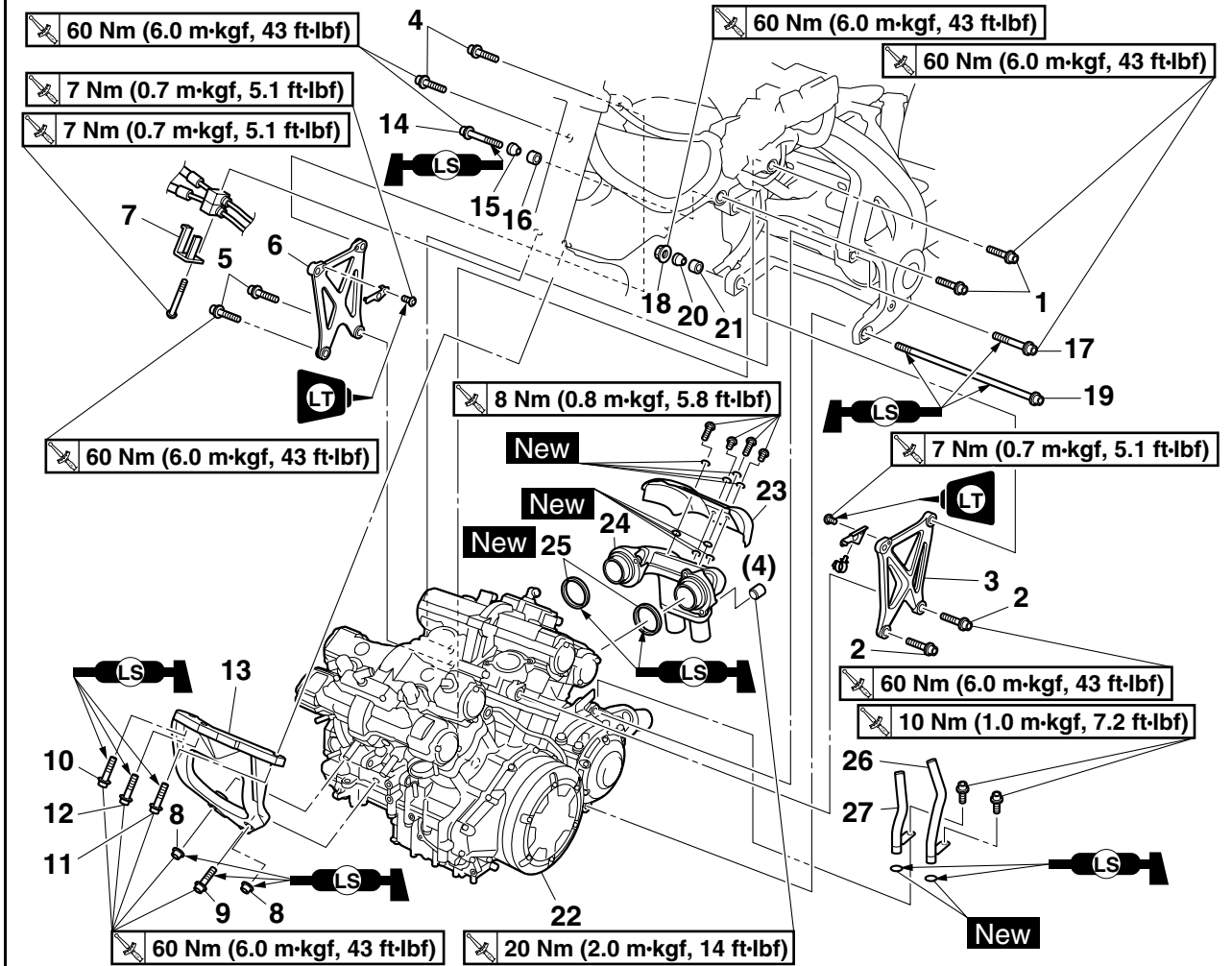

Order	Job/Parts to remove	Q'ty	Remarks
			TIP _____ Place a suitable stand under the engine.
1	Engine bracket bolt (left side)	2	
2	Engine mounting bolt (left side)	2	
3	Engine bracket (left side)	1	
4	Engine bracket bolt (right side)	2	
5	Engine mounting bolt (right side)	2	
6	Engine bracket (right side)	1	
7	Brake hose joint holder	1	
8	Engine mounting nut (front side)	2	
9	Engine mounting bolt (front side)	1	
10	Engine bracket bolt (front right side)	1	
11	Engine bracket bolt (front left side)	1	
12	Engine bracket bolt (front center side)	1	
13	Engine bracket (front side)	1	
14	Engine mounting bolt (rear right upper side)	1	
15	Engine mounting collar (outside)	1	

ENGINE REMOVAL

Removing the engine

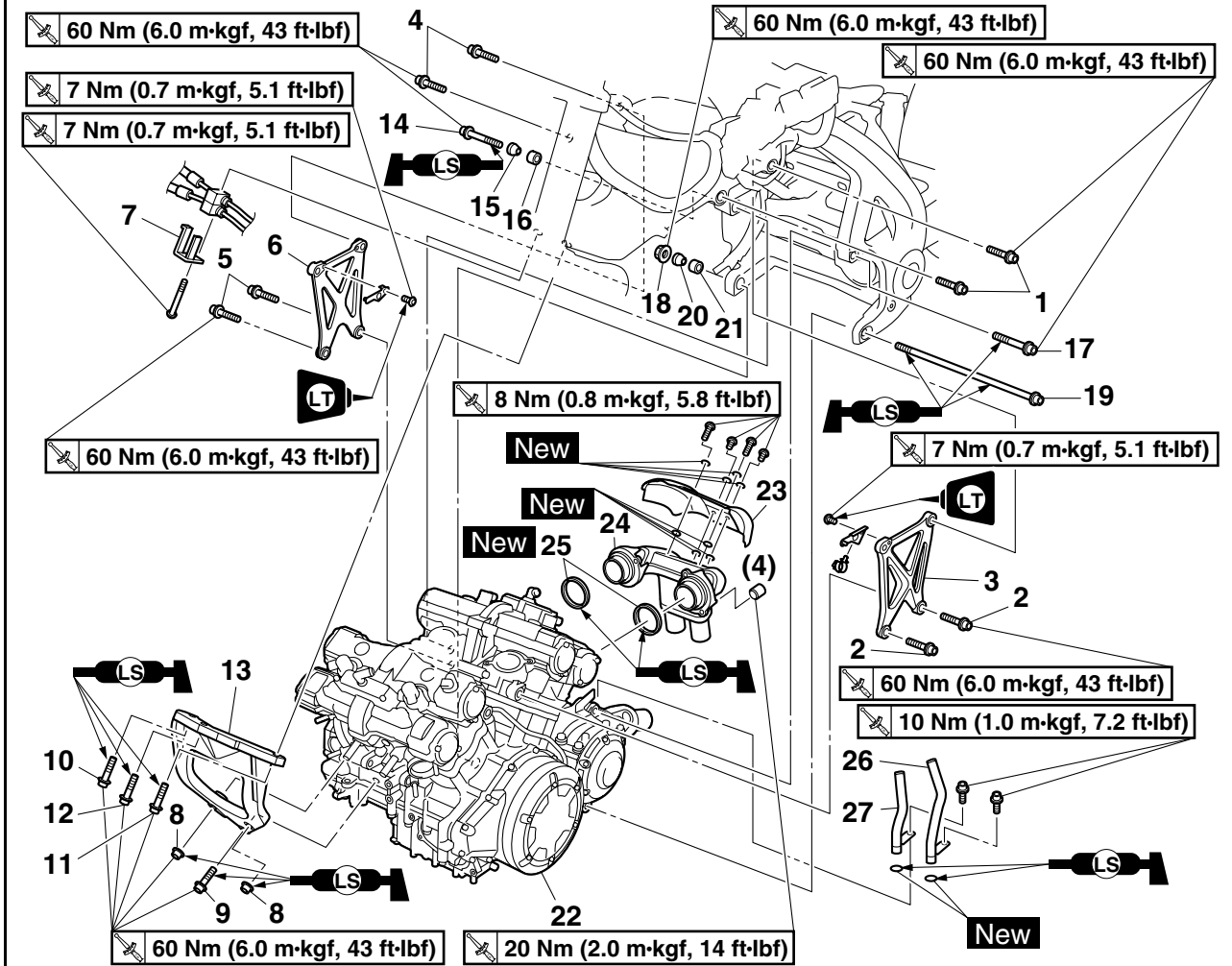

Order	Job/Parts to remove	Q'ty	Remarks
16	Engine mounting collar (inside)	1	
17	Engine mounting bolt (rear left upper side)	1	
18	Engine mounting nut (rear lower side)	1	
19	Engine mounting bolt (rear lower side)	1	
20	Engine mounting collar (outside)	1	
21	Engine mounting collar (inside)	1	
22	Engine	1	TIP Remove the engine through the right front of the vehicle.
23	Rear exhaust pipe protector	1	
24	Rear exhaust pipe	1	
25	Gasket	2	
26	Crankcase breather pipe	1	
27	Cylinder head breather pipe (lower side)	1	
			For installation, reverse the removal procedure.

EAS23720

INSTALLING THE ENGINE

1. Install:

- Engine mounting collar (inside) “1”
- Engine mounting collar (outside) “2”
- Engine mounting collar (inside) “3”
- Engine mounting collar (outside) “4”
- Engine “5”
- Engine mounting bolt (rear lower side) “6”
- Engine mounting nut (rear lower side) “7”
- Engine mounting bolt (rear left upper side) “8”
- Engine mounting bolt (rear right upper side) “9”
- Engine bracket (front side) “10”
- Engine bracket bolt (front center side) “11”
- Engine bracket bolt (front left side) “12”
- Engine bracket bolt (front right side) “13”
- Engine mounting bolt (front side) “14”
- Engine mounting nuts (front side) “15”

TIP

- Lubricate the engine mounting bolt threads (front and rear) and engine bracket bolt threads (front center, front right and front left) with lithium-soap-based grease.
- Do not fully tighten the bolts and nuts.

2. Tighten:

- Engine bracket bolt (front center side) “11”
- Engine bracket bolt (front left side) “12”
- Engine bracket bolt (front right side) “13”
- Engine mounting bolt (front side) “14”
- Engine mounting nuts (front side) “15”
- Engine mounting nut (rear lower side) “7”
- Engine mounting bolt (rear left upper side) “8”
- Engine mounting bolt (rear right upper side) “9”



Engine bracket bolt (front center side)

60 Nm (6.0 m·kgf, 43 ft·lbf)

Engine bracket bolt (front left side)

60 Nm (6.0 m·kgf, 43 ft·lbf)

Engine bracket bolt (front right side)

60 Nm (6.0 m·kgf, 43 ft·lbf)

Engine mounting bolt (front side)

60 Nm (6.0 m·kgf, 43 ft·lbf)

Engine mounting nut (front side)

60 Nm (6.0 m·kgf, 43 ft·lbf)

Engine mounting nut (rear lower side)

60 Nm (6.0 m·kgf, 43 ft·lbf)

Engine mounting bolt (rear left upper side)

60 Nm (6.0 m·kgf, 43 ft·lbf)

Engine mounting bolt (rear right upper side)

60 Nm (6.0 m·kgf, 43 ft·lbf)

3. Install:

- Engine bracket (left side) “16”
- Engine mounting bolts (left side) “17”
- Engine bracket bolts (left side) “18”
- Engine bracket (right side) “19”
- Engine mounting bolts (right side) “20”
- Engine bracket bolts (right side) “21”

TIP

Do not fully tighten the bolts.

4. Tighten:

- Engine mounting bolts (left side) “17”
- Engine bracket bolts (left side) “18”
- Engine mounting bolts (right side) “20”
- Engine bracket bolts (right side) “21”



Engine mounting bolt (left side)

60 Nm (6.0 m·kgf, 43 ft·lbf)

Engine bracket bolt (left side)

60 Nm (6.0 m·kgf, 43 ft·lbf)

Engine mounting bolt (right side)

60 Nm (6.0 m·kgf, 43 ft·lbf)

Engine bracket bolt (right side)

60 Nm (6.0 m·kgf, 43 ft·lbf)

EAS23760

CAMSHAFTS

Removing the cylinder head covers

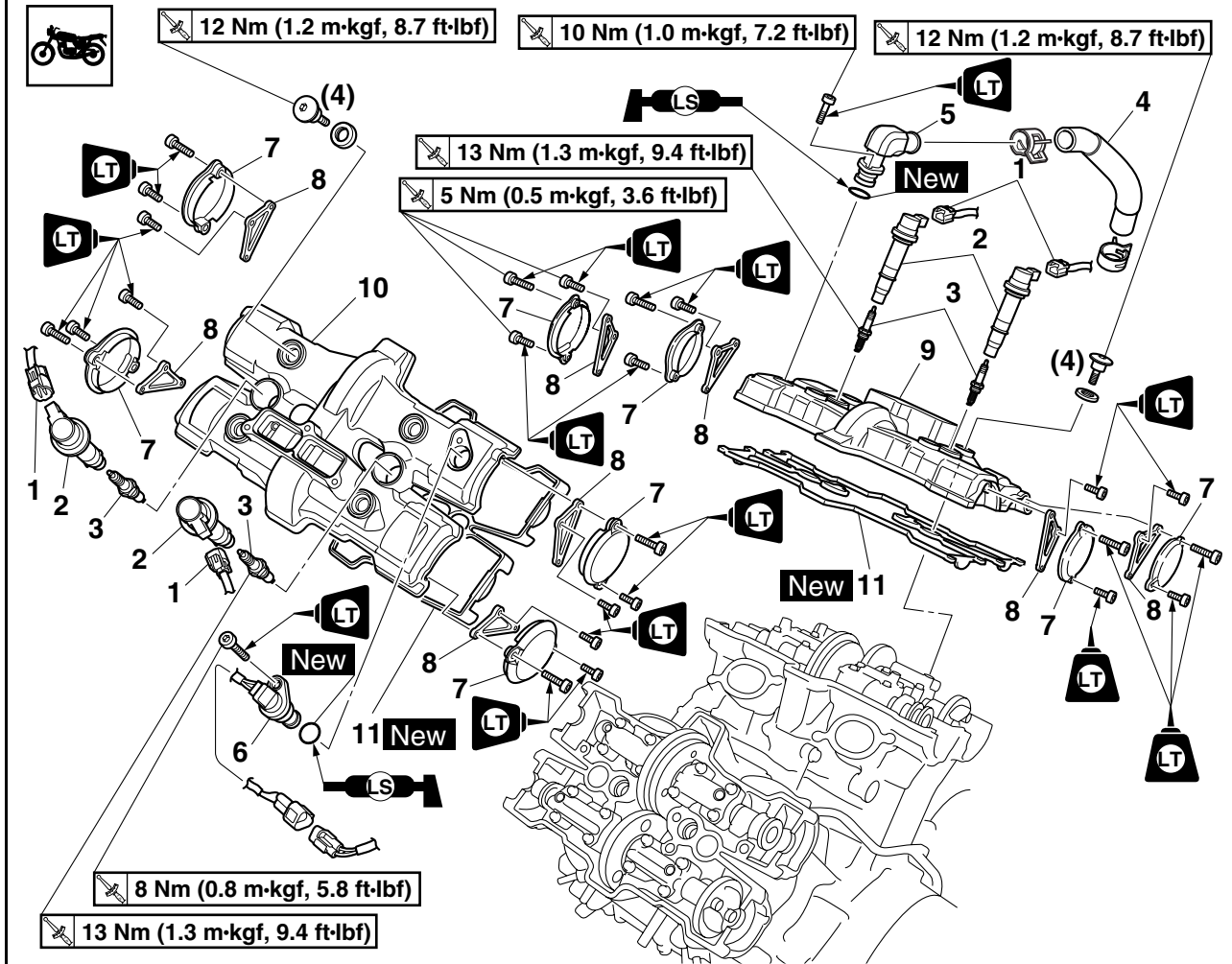

Order	Job/Parts to remove	Q'ty	Remarks
	Front exhaust pipes		Refer to "ENGINE REMOVAL" on page 5-1.
	Engine bracket (front side)		Refer to "ENGINE REMOVAL" on page 5-1.
	Radiator assembly		Refer to "RADIATORS" on page 6-1.
	Thermostat inlet pipes		Refer to "THERMOSTAT" on page 6-7.
	Throttle bodies		Refer to "THROTTLE BODIES" on page 7-11.
	Air induction system hoses/Air induction system pipe/Reed valve assembly		Refer to "AIR INDUCTION SYSTEM" on page 7-19.
1	Ignition coil coupler	4	Disconnect.
2	Ignition coil	4	
3	Spark plug	4	
4	Cylinder head breather hose	1	
5	Cylinder head breather pipe (upper side)	1	
6	Cylinder identification sensor	1	
7	Cylinder head side cover	8	
8	Cylinder head side cover plate	8	
9	Rear cylinder head cover	1	

Removing the cylinder head covers

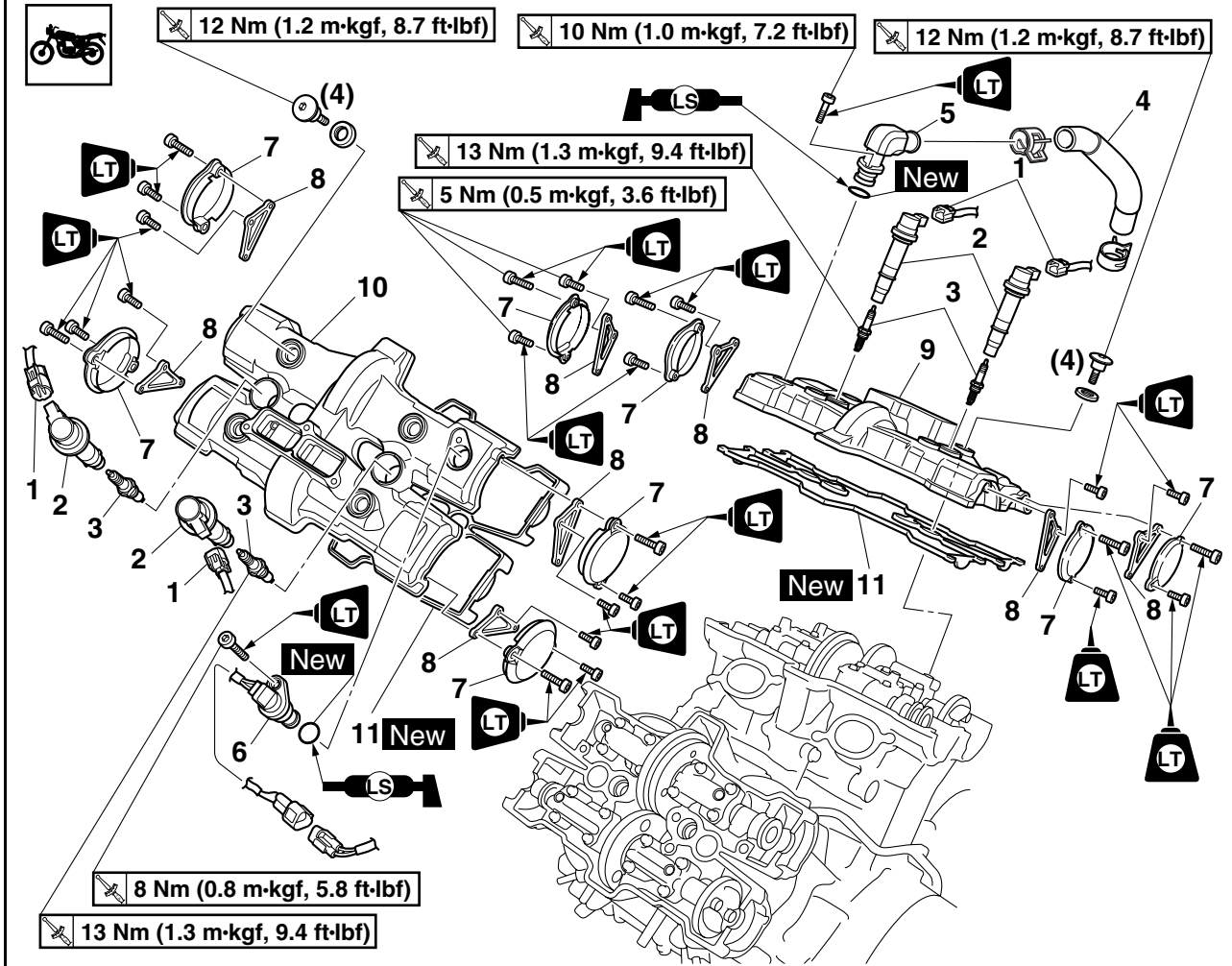

Order	Job/Parts to remove	Q'ty	Remarks
10	Front cylinder head cover	1	
11	Cylinder head cover gasket	2	
			For installation, reverse the removal procedure.

Removing the camshafts

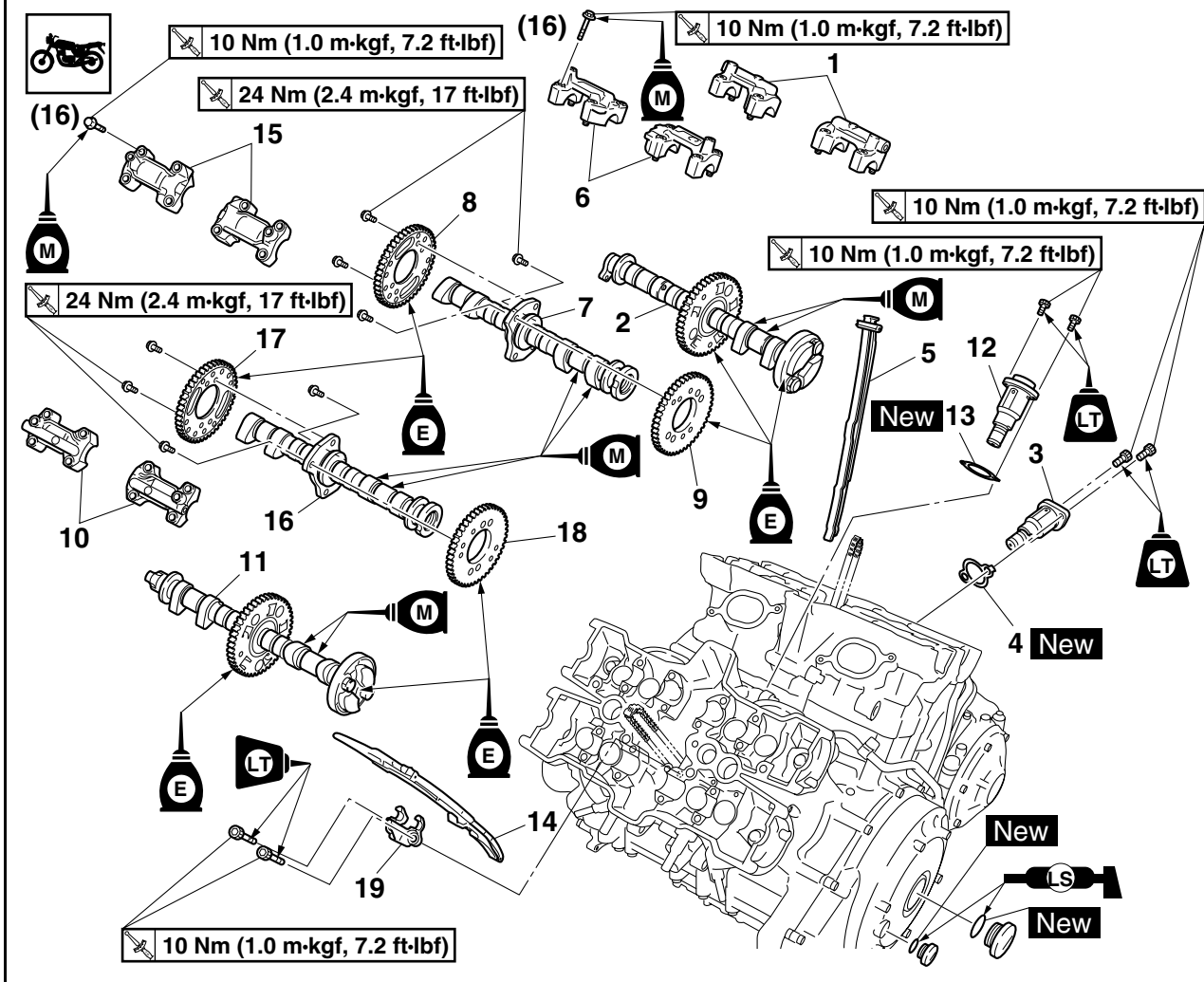

Order	Job/Parts to remove	Q'ty	Remarks
	Fuel tank		Refer to "FUEL TANK" on page 7-1.
	Generator cover plate		Refer to "GENERATOR AND STARTER CLUTCH" on page 5-37.
1	Exhaust camshaft cap (rear cylinders)	2	
2	Exhaust camshaft (rear cylinders)	1	
3	Timing chain tensioner (rear cylinders)	1	TIP To provide clearance for removing the timing chain tensioner (rear cylinders), remove the rear exhaust pipe nuts and pull the exhaust pipe rearward.
4	Timing chain tensioner gasket (rear cylinders)	1	
5	Rear cylinder timing chain guide (intake side)	1	
6	Intake camshaft cap (rear cylinders)	2	
7	Intake camshaft (rear cylinders)	1	
8	Intake camshaft sprocket (rear cylinders)	1	
9	Intake camshaft gear (rear cylinders)	1	
10	Exhaust camshaft cap (front cylinders)	2	
11	Exhaust camshaft (front cylinders)	1	

Removing the camshafts

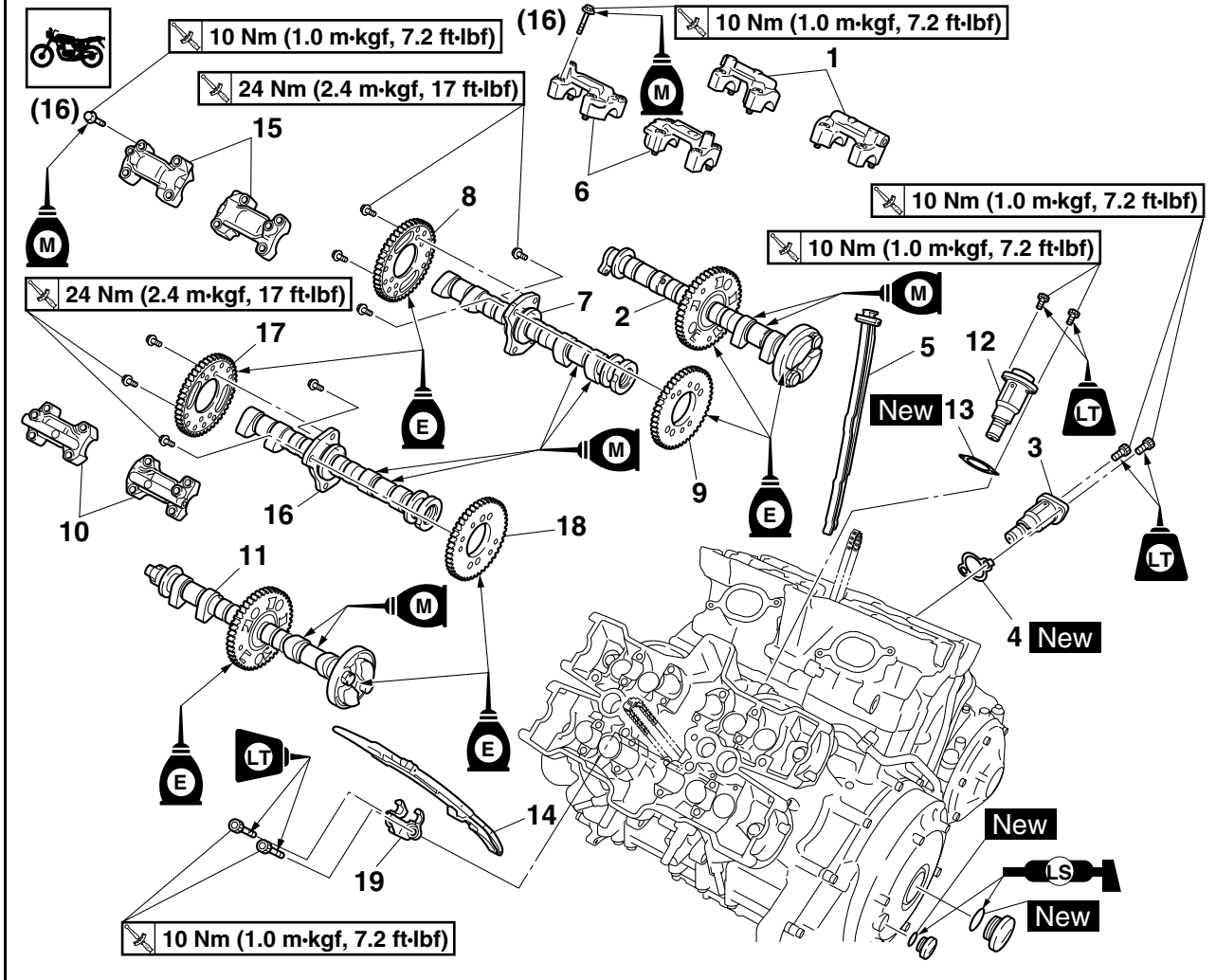

Order	Job/Parts to remove	Q'ty	Remarks
12	Timing chain tensioner (front cylinders)	1	
13	Timing chain tensioner gasket (front cylinders)	1	
14	Front cylinder timing chain guide (exhaust side)	1	
15	Intake camshaft cap (front cylinders)	2	
16	Intake camshaft (front cylinders)	1	
17	Intake camshaft sprocket (front cylinders)	1	
18	Intake camshaft gear (front cylinders)	1	
19	Timing chain guide stopper	1	
			For installation, reverse the removal procedure.

TIP

While holding the camshaft sprocket and camshaft gear with the rotor holding tool "1", loosen the camshaft sprocket bolts and camshaft gear bolts.

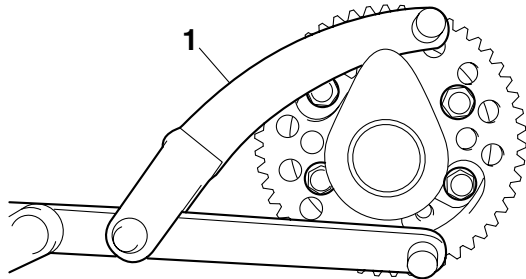

Front cylinders

TIP

When removing the front cylinder camshafts, repeat the rear cylinder camshaft removal procedure. However, note the following points.

1. Position:
 - Piston #2 (at TDC)

- a. Position piston #2 at TDC by turning the crankshaft counterclockwise until the "T2" mark "a" on the generator rotor is aligned with the stationary pointer "b" on the generator cover.

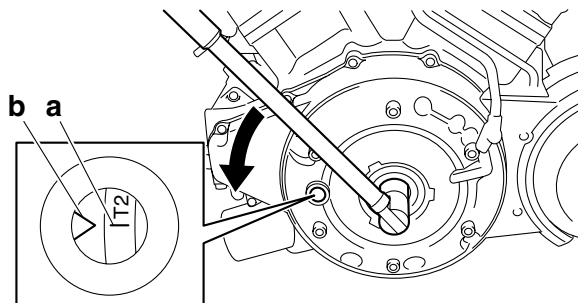

TIP

TDC on the compression stroke can be found when the "1" mark "c" in the intake camshaft gear (front cylinders) is aligned with the edge of the cylinder head "d"

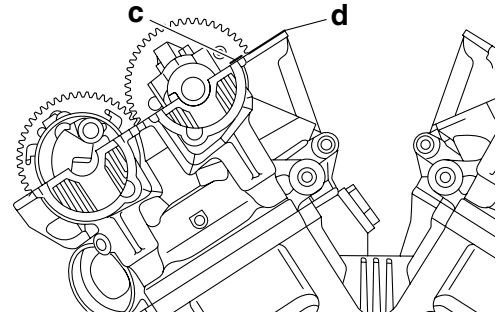

EAS23850

CHECKING THE CAMSHAFTS

The following procedure applies to all of the camshafts.

1. Check:
 - Camshaft lobes
Blue discoloration/pitting/scratches → Replace the camshaft.
2. Measure:
 - Camshaft lobe dimensions "a" and "b"
Out of specification → Replace the camshaft.



Camshaft lobe dimensions

Intake A

32.850–32.950 mm (1.2933–1.2972 in)

Limit

32.750 mm (1.2894 in)

Intake B

24.131–24.231 mm (0.9500–0.9540 in)

Limit

24.031 mm (0.9461 in)

Exhaust A

32.850–32.950 mm (1.2933–1.2972 in)

Limit

32.750 mm (1.2894 in)

Exhaust B

24.131–24.231 mm (0.9500–0.9540 in)

Limit

24.031 mm (0.9461 in)

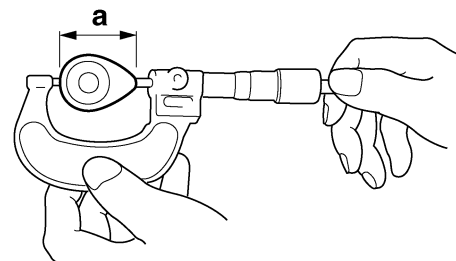

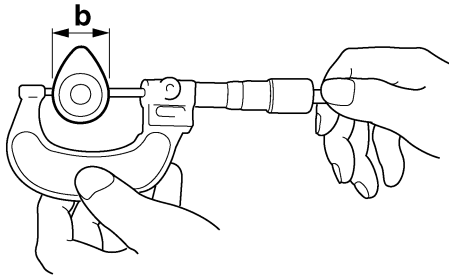

3. Measure:
- Camshaft runout
Out of specification → Replace.

	Camshaft runout limit 0.030 mm (0.0012 in)
---	--

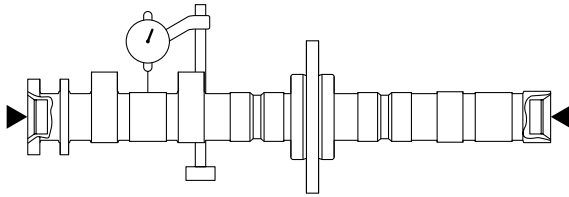

4. Measure:
- Camshaft-journal-to-camshaft-cap clearance
Out of specification → Measure the camshaft journal diameter.

	Camshaft-journal-to-camshaft-cap clearance 0.028–0.062 mm (0.0011–0.0024 in)
---	--

- a. Install the camshaft into the cylinder head (without the camshaft caps).
b. Position a strip of Plastigauge® “1” onto the camshaft journal as shown.

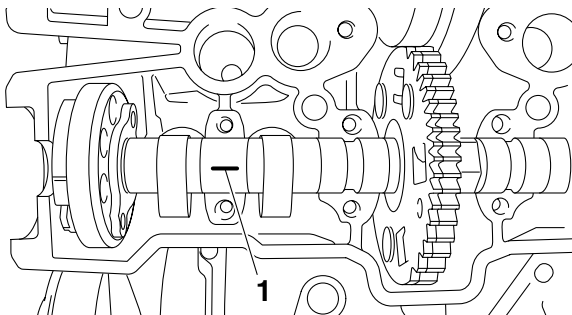

- c. Install the camshaft caps.

TIP

- Tighten the camshaft cap bolts in stages and in a crisscross pattern, working from the inner caps out.
- Do not turn the camshaft when measuring the camshaft journal-to-camshaft cap clearance with the Plastigauge®.

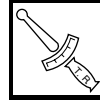

Camshaft cap bolt
10 Nm (1.0 m·kgf, 7.2 ft·lbf)

- d. Remove the camshaft caps and then measure the width of the Plastigauge® “1”.

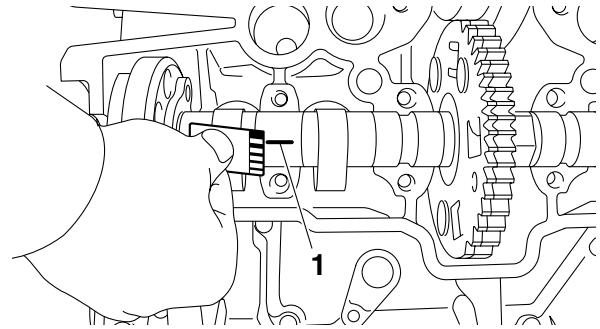

5. Measure:

- Camshaft journal diameter “a”
Out of specification → Replace the camshaft.
Within specification → Replace the cylinder head and the camshaft caps as a set.



Camshaft journal diameter
21.959–21.972 mm (0.8645–0.8650 in)

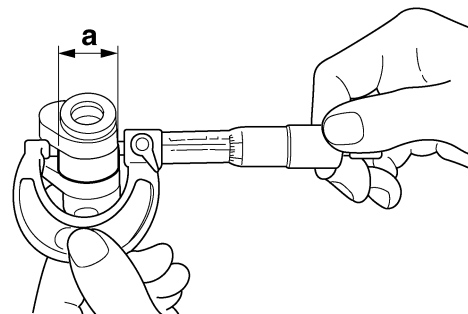

EAS23870

CHECKING THE CAMSHAFT SPROCKETS

The following procedure applies to both of the camshaft sprockets.

1. Check:
- Camshaft sprocket
More than 1/4 tooth wear “a” → Replace the camshaft sprocket, timing chain, and crankshaft as a set.

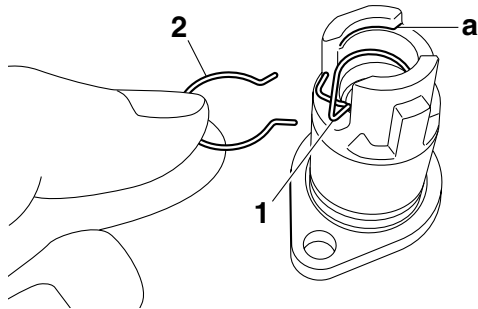

- b. Install the timing chain tensioner spring, timing chain tensioner spring seat, and timing chain tensioner rod.
- c. Squeeze timing chain tensioner clip 2 “1”, and then push the timing chain tensioner rod “3” into the timing chain tensioner housing.

TIP

Do not release timing chain tensioner clip 2 while pushing the rod into the housing; otherwise, the rod may be ejected.

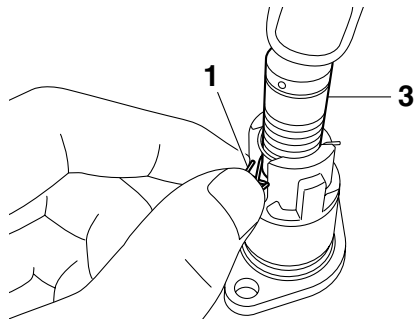

- d. Align the groove “b” in the timing chain tensioner rod with timing chain tensioner clip 1 “2”, and then squeeze the clip to fit it into the groove.

TIP

Make sure that the timing chain tensioner rod is secured by the clip; otherwise, the rod may be ejected.

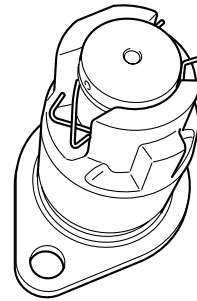
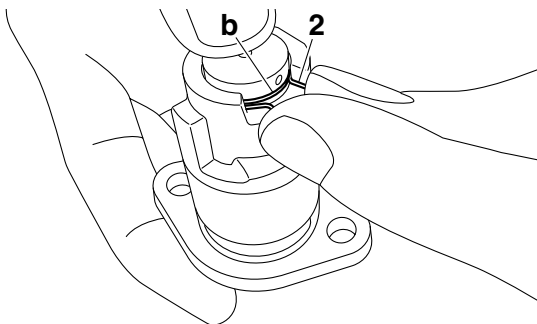

EAS24020

INSTALLING THE CAMSHAFTS

Front cylinders-intake side

1. Install:

- Intake camshaft gear “1”



Intake camshaft gear bolt
24 Nm (2.4 m·kgf, 17 ft·lbf)

TIP

- Install the camshaft gear onto the left side of the camshaft.
- Install the camshaft gear so that the bolt hole next to the “F” mark “a” is aligned with the bolt hole on the camshaft.
- While holding the camshaft gear with the rotor holding tool “2”, tighten the camshaft gear bolts.



Rotor holding tool
90890-01235
Universal magneto & rotor holder
YU-01235

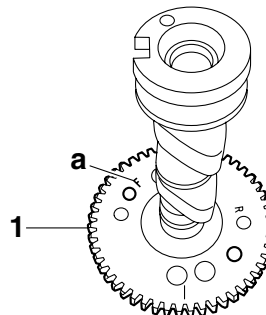

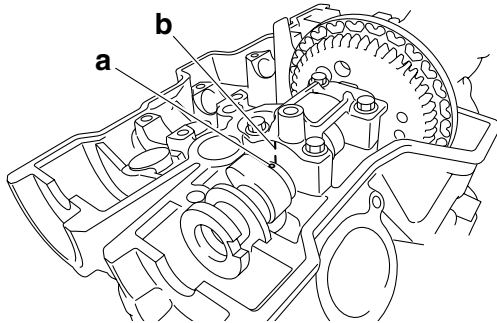

5. Install:
- Intake camshaft cap bolts



Intake camshaft cap bolt
10 Nm (1.0 m·kgf, 7.2 ft·lbf)

ECA2S31035

NOTICE

The camshaft cap bolts must be tightened evenly; otherwise, the cylinder head, camshaft caps, and camshaft will be damaged.

TIP

- Lubricate the camshaft cap bolt mating surface with molybdenum disulfide oil.
- Tighten the camshaft cap bolts in stages and in a crisscross pattern.

6. Install:
- Timing chain guide
7. Install:

- Timing chain tensioner gasket "1" **New**
- Timing chain tensioner "2"



Timing chain tensioner bolt
10 Nm (1.0 m·kgf, 7.2 ft·lbf)
LOCTITE®

TIP

- Be sure to install the timing chain tensioner gasket so that its projection "a" is protruding from the upper left side of the timing chain tensioner.
- The arrow mark "b" on the timing chain tensioner should face up.

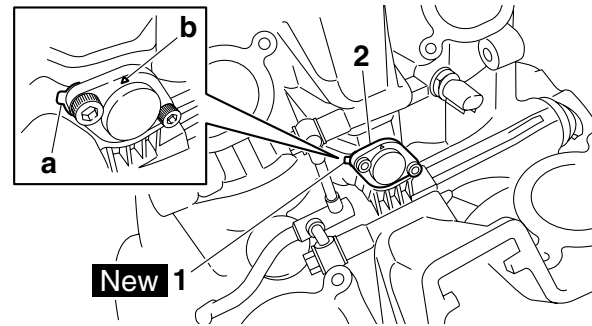

8. Rotate the crankshaft counterclockwise a few times to release the timing chain tensioner rod.

TIP

If the timing chain tensioner rod does not release, rotate the crankshaft clockwise.

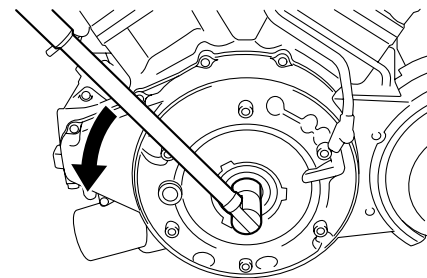

9. Check that the timing chain is taut. If the chain is slack, reinstall the timing chain tensioner.

Front cylinders-exhaust side

1. Find:
- Front cylinders-exhaust camshaft installation position



- a. Make sure that the "F" mark on the generator rotor is aligned with the stationary pointer on the generator cover.
- b. Turn the crankshaft about a turn and 1/3 (497 degrees) counterclockwise until the "T2" mark "a" on the generator rotor is aligned with the stationary pointer "b" on the generator cover.

TIP

Piston #2 is at TDC when the "T2" mark on the generator rotor is aligned with the stationary pointer on the generator cover.

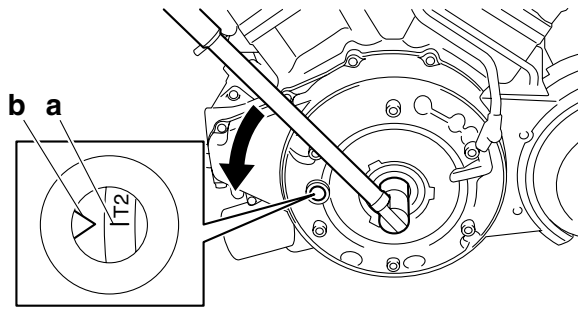

2. Install:

- Exhaust camshaft "1"
- Exhaust camshaft caps "2"

ECA2S31034

NOTICE

Do not turn the crankshaft when installing the camshaft to avoid damage or improper valve timing.

TIP

- Make sure the punch mark "a" on the intake camshaft gear is aligned with punch mark "b" on the exhaust camshaft gear.
- Insert a cross-headed screwdriver "3" into one of the holes of the exhaust camshaft gear, and then rotate the outer exhaust camshaft gear until both exhaust camshaft gears are aligned. The teeth of both exhaust camshaft gears must be aligned for installation.
- Make sure each camshaft cap is installed in its original place. Refer to the identification marks as follows:
Exhaust-left side: "2S3-78"
Exhaust-right side: "2S3-83"

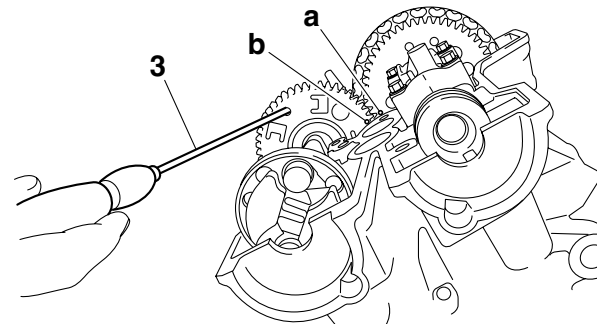
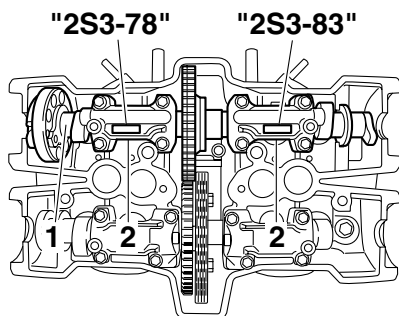

3. Install:

- Exhaust camshaft cap bolts



**Exhaust camshaft cap bolt
10 Nm (1.0 m·kgf, 7.2 ft·lbf)**

ECA2S31035

NOTICE

The camshaft cap bolts must be tightened evenly; otherwise, the cylinder head, camshaft caps, and camshaft will be damaged.

TIP

- Lubricate the camshaft cap bolt mating surface with molybdenum disulfide oil.
- Tighten the camshaft cap bolts in stages and in a crisscross pattern.

4. Check:

- "l" mark on the intake camshaft gear (with the edge of the cylinder head)

TIP

Check that the "l" mark "a" on the intake camshaft gear is aligned with the edge of the cylinder head "b".

Out of alignment → Adjust.

Refer to the installation steps above.

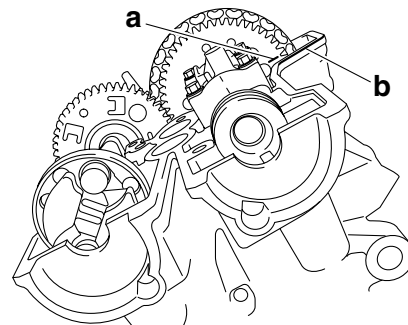

Rear cylinders-intake side

1. Install:

- Intake camshaft gear "1"



Intake camshaft gear bolt
24 Nm (2.4 m·kgf, 17 ft·lbf)

TIP

- Install the camshaft gear onto the left side of the camshaft.
- Install the camshaft gear so that the bolt hole next to the “R” mark “a” is aligned with the bolt hole on the camshaft.
- While holding the camshaft gear with the rotor holding tool “2”, tighten the camshaft gear bolts.



Rotor holding tool
90890-01235
Universal magneto & rotor holder
YU-01235

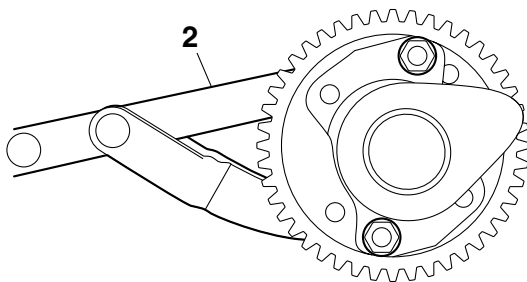
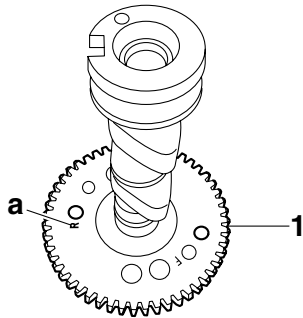

2. Install:

- Intake camshaft sprocket “1”



Intake camshaft sprocket bolt
24 Nm (2.4 m·kgf, 17 ft·lbf)

TIP

- Install the camshaft sprocket so that the bolt hole next to the “R” mark “a” is aligned with the bolt hole on the camshaft.
- While holding the camshaft sprocket with the rotor holding tool “2”, tighten the camshaft sprocket bolts.



Rotor holding tool
90890-01235
Universal magneto & rotor holder
YU-01235

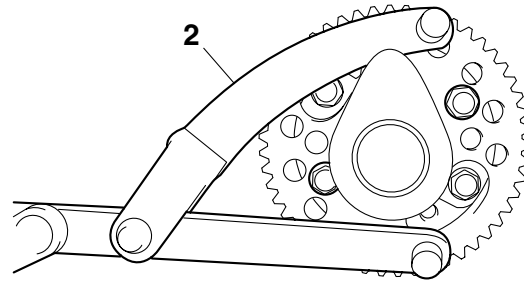
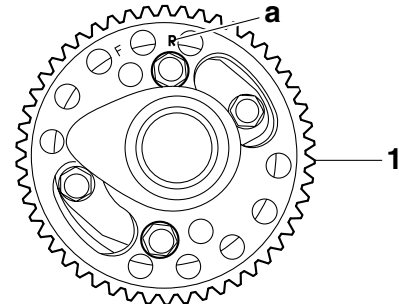

3. Find:

- Rear cylinders-intake camshaft installation position



- Make sure that piston #2 is at TDC.
- Turn the crankshaft about a turn and 1/4 (462 degrees) counterclockwise until the “R” mark “a” on the generator rotor is aligned with the stationary pointer “b” on the generator cover.

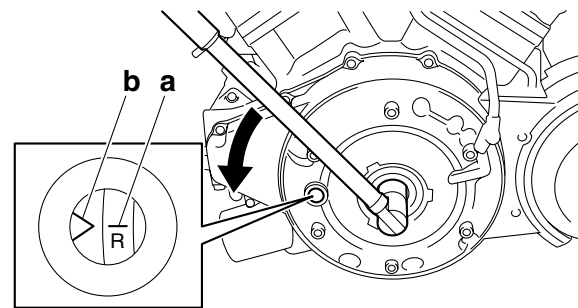

4. Install:

- Intake camshaft “1” (with the camshaft gear and camshaft sprocket)
- Timing chain
- Intake camshaft caps “2”

ECA2S31034

NOTICE

Do not turn the crankshaft when installing the camshaft to avoid damage or improper valve timing.

TIP

- Be sure to install the timing chain so that the intake side of the chain is taut and the exhaust side is slack.

- Make sure each camshaft cap is installed in its original place. Refer to the identification marks as follows:

Intake-left side: "2S3-73"

Intake-right side: "2S3-93"

- Make sure the punch mark "a" in the camshaft is aligned with "l" mark "b" in the camshaft cap.

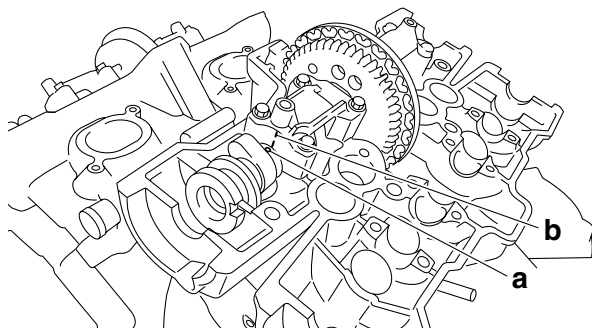
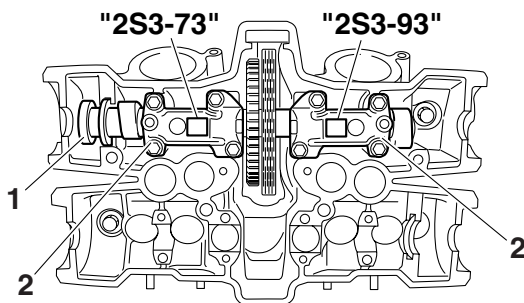

5. Install:

- Intake camshaft cap bolts



**Intake camshaft cap bolt
10 Nm (1.0 m·kgf, 7.2 ft·lbf)**

ECA2S31035

NOTICE

The camshaft cap bolts must be tightened evenly; otherwise, the cylinder head, camshaft caps, and camshaft will be damaged.

TIP

- Lubricate the camshaft cap bolt mating surface with molybdenum disulfide oil.

- Tighten the camshaft cap bolts in stages and in a crisscross pattern.

6. Install:

- Timing chain guide

7. Install:

- Timing chain tensioner gasket "1" **New**
- Timing chain tensioner "2"



**Timing chain tensioner bolt
10 Nm (1.0 m·kgf, 7.2 ft·lbf)
LOCTITE®**

TIP

- Be sure to install the timing chain tensioner gasket so that its projection "a" is protruding from the upper left side of the timing chain tensioner.

- The arrow mark "b" on the timing chain tensioner should face up.

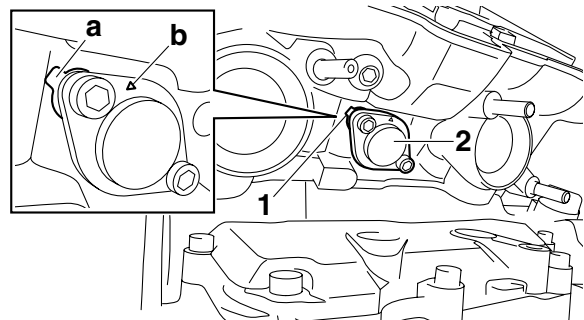

8. Rotate the crankshaft counterclockwise a few times to release the timing chain tensioner rod.

TIP

If the timing chain tensioner rod does not release, rotate the crankshaft clockwise.

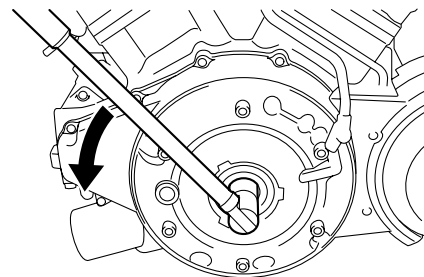

- Check that the timing chain is taut. If the chain is slack, reinstall the timing chain tensioner.

Rear cylinders-exhaust side

- Find:
 - Rear cylinders-exhaust camshaft installation position

- Make sure that the "R" mark on the generator rotor is aligned with the stationary pointer on the generator cover.
- Turn the crankshaft about a turn and 1/2 (553 degrees) counterclockwise until the "T1" mark "a" on the generator rotor is aligned with the stationary pointer "b" on the generator cover.

TIP

Piston #1 is at TDC when the "T1" mark on the generator rotor is aligned with the stationary pointer on the generator cover.

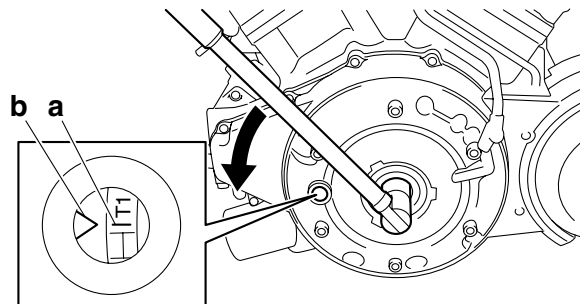

- Install:
 - Exhaust camshaft "1"
 - Exhaust camshaft caps "2"

ECA2S31034

NOTICE

Do not turn the crankshaft when installing the camshaft to avoid damage or improper valve timing.

TIP

- Make sure the punch mark "a" on the intake camshaft gear is aligned with punch mark "b" in the exhaust camshaft gear.
- Insert a cross-headed screwdriver "3" into one of the holes of the exhaust camshaft gear, and then rotate the outer exhaust camshaft gear until both exhaust camshaft gears are aligned. The teeth of both exhaust camshaft gears must be aligned for installation.

- Make sure each camshaft cap is installed in its original place. Refer to the identification marks as follows:

Exhaust-left side: "2S3-83"

Exhaust-right side: "2S3-78"

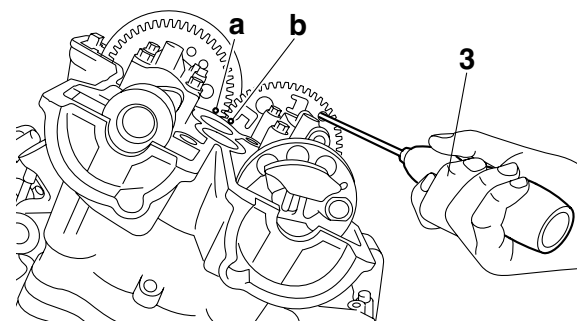
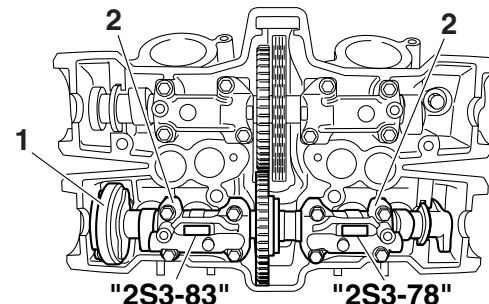

- Install:
 - Exhaust camshaft cap bolts

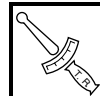

**Exhaust camshaft cap bolt
10 Nm (1.0 m·kgf, 7.2 ft·lbf)**

ECA2S31035

NOTICE

The camshaft cap bolts must be tightened evenly; otherwise, the cylinder head, camshaft caps, and camshaft will be damaged.

TIP

- Lubricate the camshaft cap bolt mating surface with molybdenum disulfide oil.
- Tighten the camshaft cap bolts in stages and in a crisscross pattern.

- Check:
 - "I" mark on the intake camshaft gear (rear cylinders) (with the edge of the cylinder head)
 - "I" mark on the intake camshaft gear (front cylinders) (above the edge of the cylinder head)

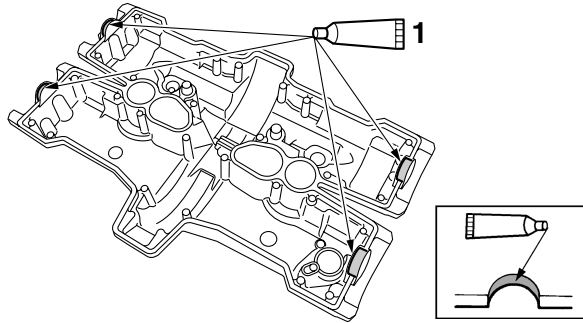

9. Install:

- Ignition coils "1"

TIP

When installing the ignition coils, make sure that the ignition coil couplers are positioned at the angles shown in the illustration.

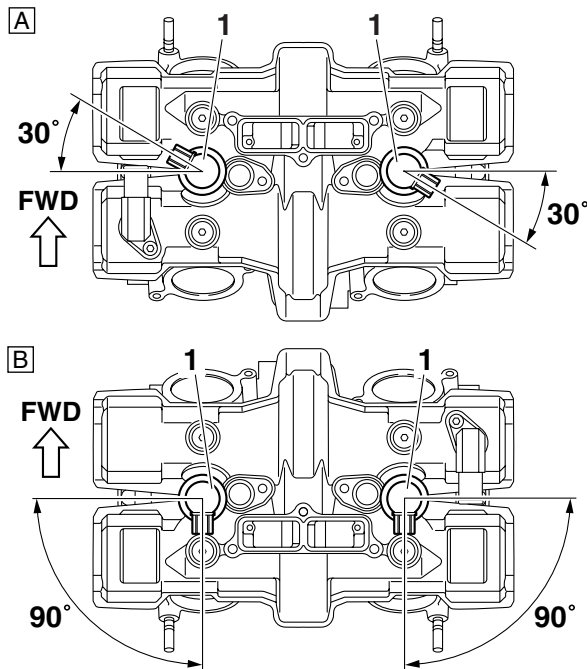

A. Front cylinders

B. Rear cylinders

EAS24110

CYLINDER HEADS

Removing the cylinder heads

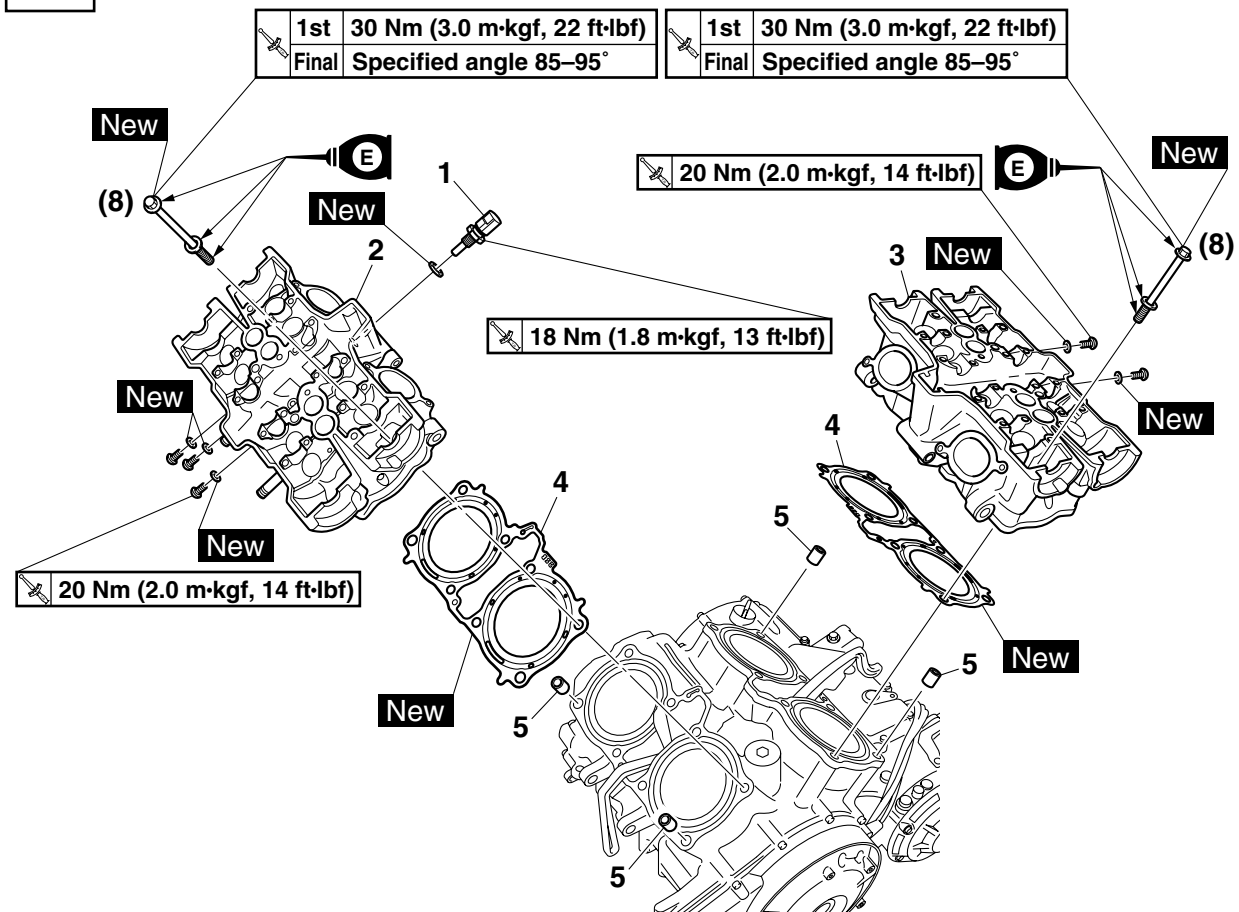

Order	Job/Parts to remove	Q'ty	Remarks
	Camshafts		Refer to "CAMSHAFTS" on page 5-9.
	Oil pipe 1		Refer to "GENERATOR AND STARTER CLUTCH" on page 5-37.
1	Coolant temperature sensor	1	
2	Front cylinder head	1	
3	Rear cylinder head	1	
4	Cylinder head gasket	2	
5	Dowel pin	4	
			For installation, reverse the removal procedure.

EAS24140

REMOVING THE CYLINDER HEADS

1. Remove:

- Cylinder head bolts

TIP

- Loosen the bolts in the proper sequence as shown.
- Loosen each bolt 1/2 of a turn at a time. After all of the bolts are fully loosened, remove them.

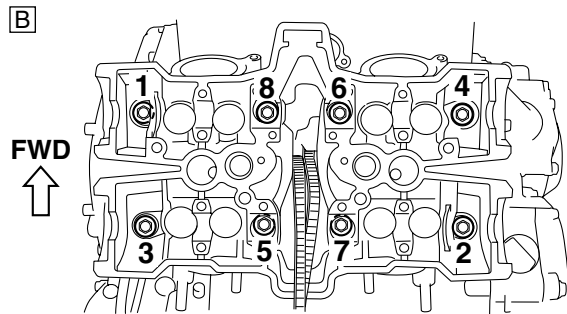
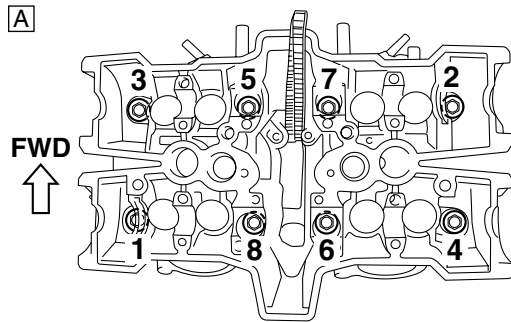
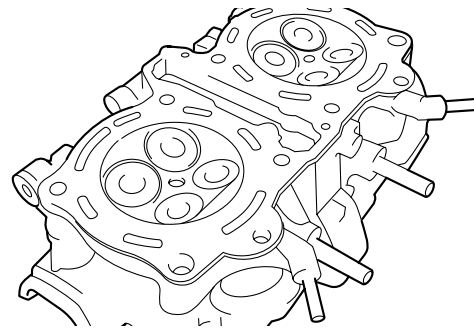

- A. Front cylinder head
- B. Rear cylinder head

EAS24170

CHECKING THE CYLINDER HEADS

The following procedure applies to both of the cylinder heads.

1. Eliminate:

- Combustion chamber carbon deposits (with a rounded scraper)

TIP

Do not use a sharp instrument to avoid damaging or scratching:

- Spark plug bore threads
- Valve seats

2. Check:

- Cylinder head
Damage/scratches → Replace.
- Cylinder head water jacket
Mineral deposits/rust → Eliminate.

3. Measure:

- Cylinder head warpage
Out of specification → Resurface the cylinder head.

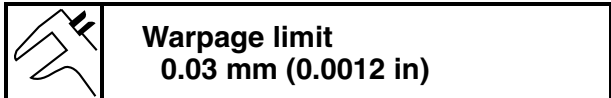

- a. Place a straightedge "1" and a thickness gauge "2" across the cylinder head.

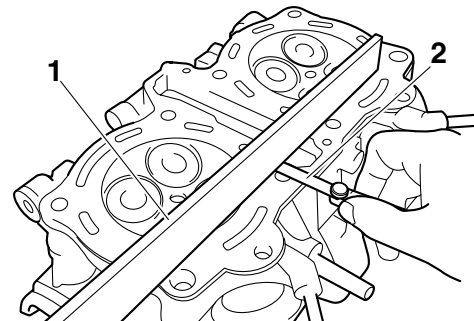

b. Measure the warpage.

c. If the limit is exceeded, resurface the cylinder head as follows.

d. Place a 400–600 grit wet sandpaper on the surface plate and resurface the cylinder head using a figure-eight sanding pattern.

TIP

To ensure an even surface, rotate the cylinder head several times.

EAS24240

INSTALLING THE CYLINDER HEADS

1. Install:

- Cylinder heads

TIP

Pass the timing chains through the timing chain cavity.

2. Tighten:

- Cylinder head bolts **New**

EWA2S31032

WARNING

Replace the bolts with new ones.

TIP

Tighten the bolts using the following procedure.

- Lubricate the cylinder head bolts with engine oil.
- Install the cylinder head bolts.
- Tighten the cylinder head bolts in the proper tightening sequence as shown.



**Cylinder head bolt
1st
30 Nm (3.0 m·kgf, 22 ft·lbf)**

- Tighten the cylinder head bolts further to reach the specified angle 85–95° in the proper tightening sequence as shown.



**Cylinder head bolt
Final
Specified angle 85–95°**

EWA2S31035

WARNING

If the bolt is tightened more than the specified angle, do not loosen the bolt and then re-tighten it. Instead, replace the bolt with a new one and perform the procedure again.

ECA2S31041

NOTICE

- Do not use a torque wrench to tighten the bolt to the specified angle.
- Tighten the bolt until it is at the specified angle.

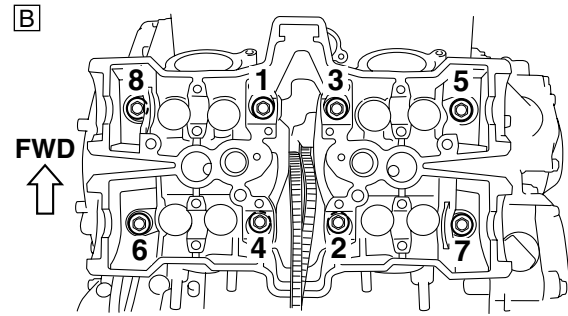
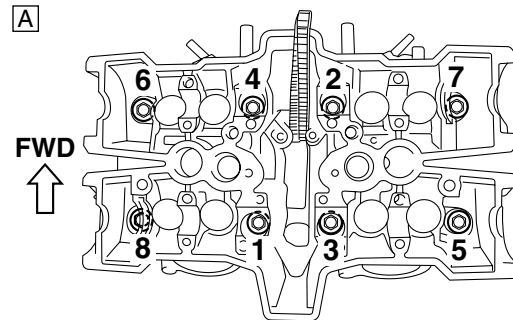

A. Front cylinder head
B. Rear cylinder head

TIP

On a hexagonal bolt, note that the angle from one corner to another is 60°.

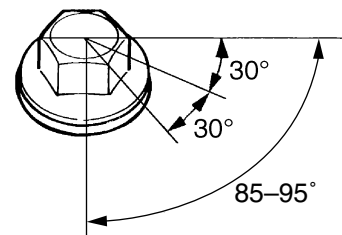

EAS24270

VALVES AND VALVE SPRINGS

Removing the valves and valve springs

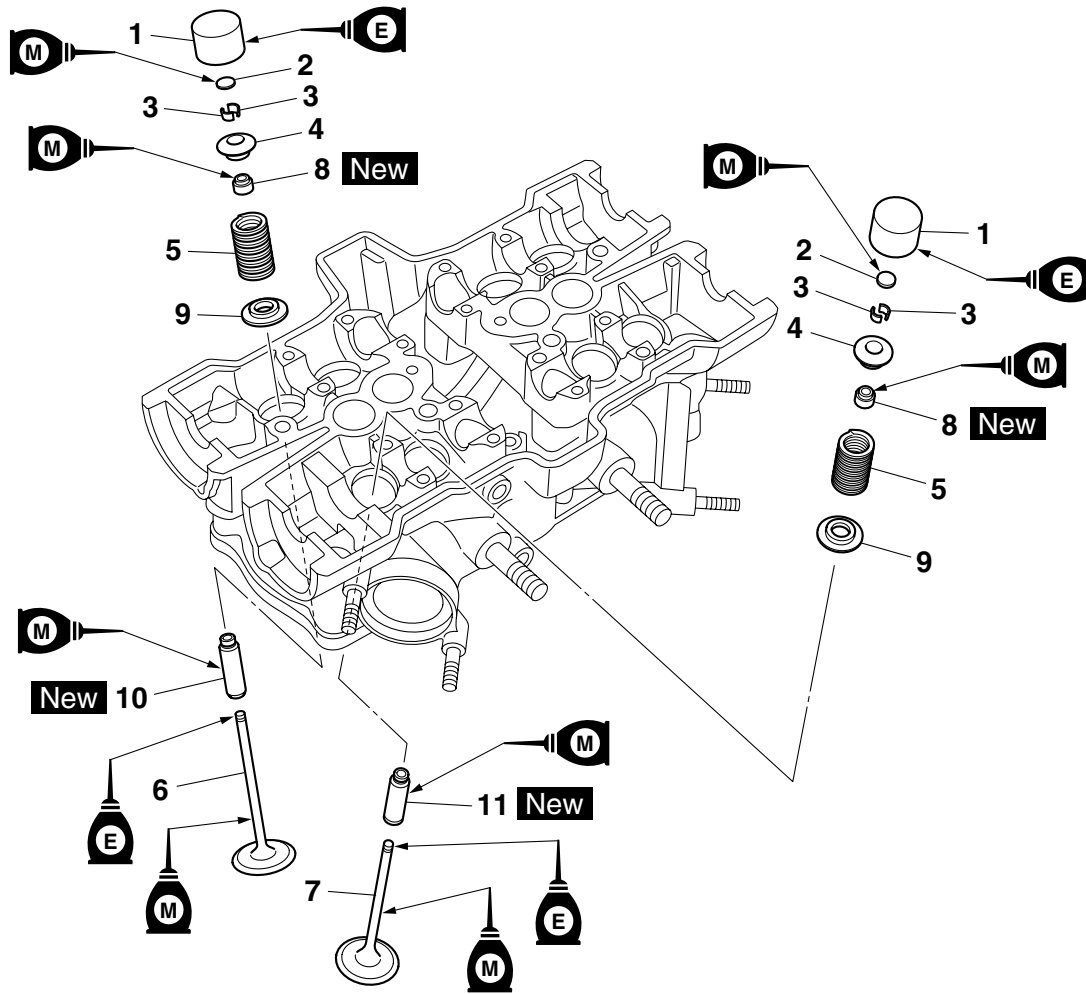

Order	Job/Parts to remove	Q'ty	Remarks
			The following procedure applies to both cylinders.
	Cylinder heads		Refer to "CYLINDER HEADS" on page 5-26.
1	Valve lifter	8	
2	Valve pad	8	
3	Valve cotter	16	
4	Valve spring retainer	8	
5	Valve spring	8	
6	Intake valve	4	
7	Exhaust valve	4	
8	Valve stem seal	8	
9	Valve spring seat	8	
10	Intake valve guide	4	Length: 35 mm (1.38 in)
11	Exhaust valve guide	4	Length: 39 mm (1.54 in)
			For installation, reverse the removal procedure.

EAS24280

REMOVING THE VALVES

The following procedure applies to all of the valves and related components.

TIP

Before removing the internal parts of the cylinder head (e.g., valves, valve springs, valve seats), make sure the valves properly seal.

1. Remove:
 - Valve lifter "1"
 - Valve pad "2"

TIP

Make a note of the position of each valve lifter and valve pad so that they can be reinstalled in their original place.

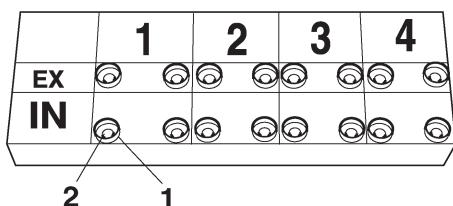

2. Check:
 - Valve sealing
Leakage at the valve seat → Check the valve face, valve seat, and valve seat width.
Refer to "CHECKING THE VALVE SEATS" on page 5-32.

- a. Pour a cleaning solvent "a" into the intake and exhaust ports.
- b. Check that the valves properly seal.

TIP

There should be no leakage at the valve seat "1".

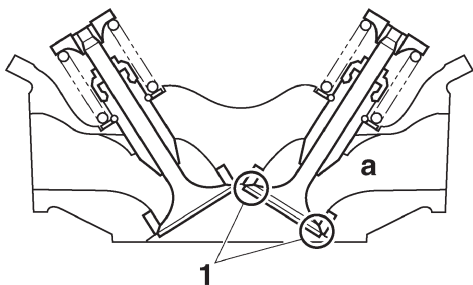

3. Remove:
 - Valve cotters

TIP

Remove the valve cotters by compressing the valve spring with the valve spring compressor "1" and the valve spring compressor attachment "2".



Valve spring compressor
90890-04019
YM-04019
Valve spring compressor attachment
90890-01243
Valve spring compressor adapter (26 mm)
YM-01253-1

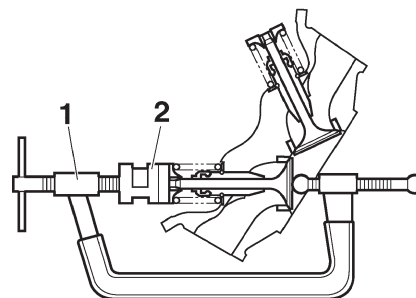

4. Remove:
 - Valve spring retainer "1"
 - Valve spring "2"
 - Valve "3"
 - Valve stem seal "4"
 - Valve spring seat "5"

TIP

Identify the position of each part very carefully so that it can be reinstalled in its original place.

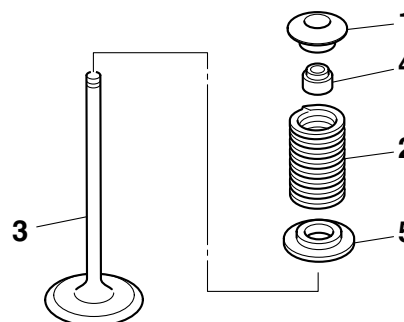

EAS24290

CHECKING THE VALVES AND VALVE GUIDES

The following procedure applies to all of the valves and valve guides.



Valve guide remover (ø5)
90890-04097
Valve guide remover (5.0 mm)
YM-04097
Valve guide installer (ø5)
90890-04098
Valve guide installer (5.0 mm)
YM-04098
Valve guide reamer (ø5)
90890-04099
Valve guide reamer (5.0 mm)
YM-04099



Valve stem runout
0.010 mm (0.0004 in)

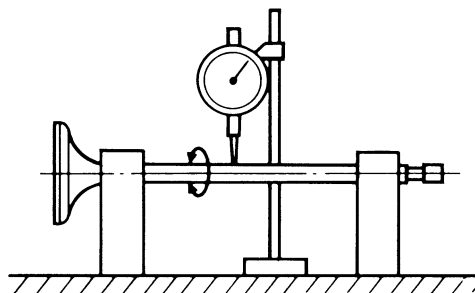

3. Eliminate:
 - Carbon deposits
(from the valve face and valve seat)
4. Check:
 - Valve face
Pitting/wear → Grind the valve face.
 - Valve stem end
Mushroom shape or diameter larger than the body of the valve stem → Replace the valve.
5. Measure:
 - Valve margin thickness D “a”
Out of specification → Replace the valve.



Valve margin thickness D (intake)
1.00 mm (0.0394 in)
Valve margin thickness D (exhaust)
1.00 mm (0.0394 in)

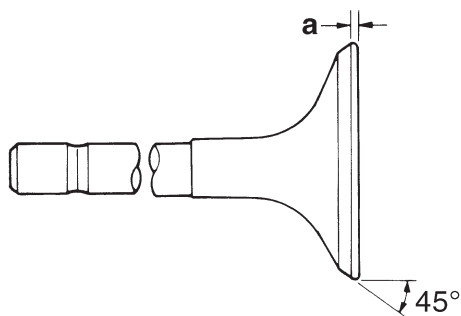

6. Measure:
 - Valve stem runout
Out of specification → Replace the valve.

TIP

- When installing a new valve, always replace the valve guide.
- If the valve is removed or replaced, always replace the valve stem seal.

EAS24300

CHECKING THE VALVE SEATS

The following procedure applies to all of the valves and valve seats.

1. Eliminate:
 - Carbon deposits
(from the valve face and valve seat)
2. Check:
 - Valve seat
Pitting/wear → Replace the cylinder head.
3. Measure:
 - Valve seat width C “a”
Out of specification → Replace the cylinder head.



Valve seat width C (intake)
1.10–1.30 mm (0.0433–0.0512 in)
Valve seat width C (exhaust)
1.10–1.30 mm (0.0433–0.0512 in)

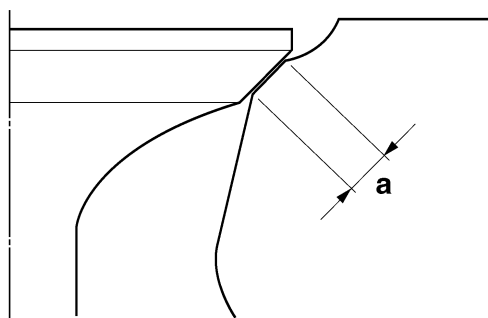

- a. Apply Mechanic’s blueing dye (Dykem) “b” onto the valve face.

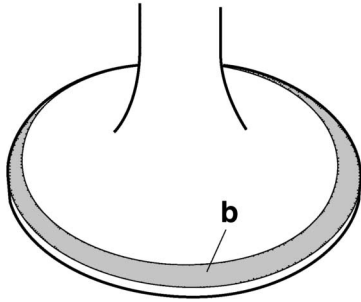

- b. Install the valve into the cylinder head.
- c. Press the valve through the valve guide and onto the valve seat to make a clear impression.
- d. Measure the valve seat width.

TIP

Where the valve seat and valve face contacted one another, the blueing will have been removed.



4. Lap:

- Valve face
- Valve seat

TIP

After replacing the cylinder head or replacing the valve and valve guide, the valve seat and valve face should be lapped.



- a. Apply a coarse lapping compound "a" to the valve face.

ECA13790

NOTICE

Do not let the lapping compound enter the gap between the valve stem and the valve guide.

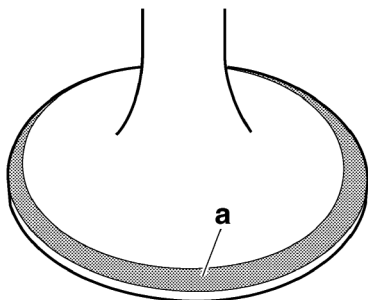

- b. Apply molybdenum disulfide oil onto the valve stem.
- c. Install the valve into the cylinder head.
- d. Turn the valve until the valve face and valve seat are evenly polished, then clean off all of the lapping compound.

TIP

For the best lapping results, lightly tap the valve seat while rotating the valve back and forth between your hands.

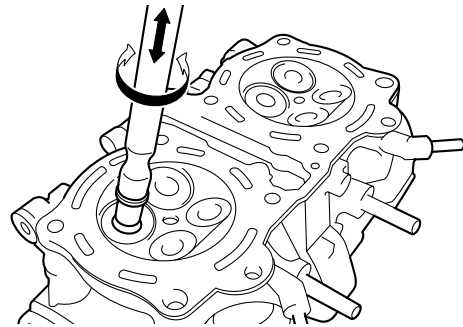

- e. Apply a fine lapping compound to the valve face and repeat the above steps.
- f. After every lapping procedure, be sure to clean off all of the lapping compound from the valve face and valve seat.
- g. Apply Mechanic's blueing dye (Dykem) "b" onto the valve face.

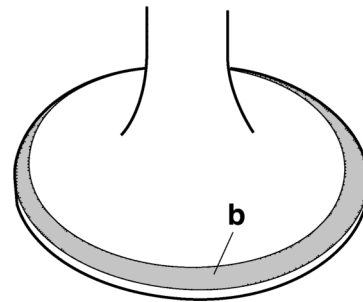

- h. Install the valve into the cylinder head.
- i. Press the valve through the valve guide and onto the valve seat to make a clear impression.
- j. Measure the valve seat width "c" again. If the valve seat width is out of specification, reface and lap the valve seat.

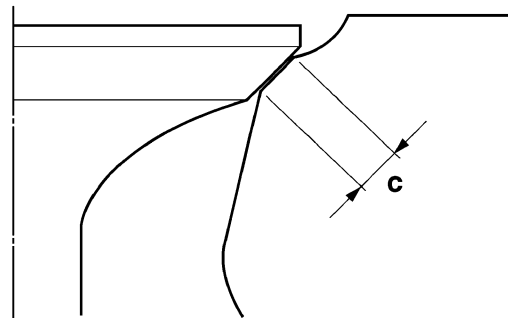

EAS24310

CHECKING THE VALVE SPRINGS

The following procedure applies to all of the valve springs.

1. Measure:

- Valve spring free length “a”
Out of specification → Replace the valve spring.

	Free length (intake) 40.78 mm (1.61 in)
	Limit 38.74 mm (1.53 in)
	Free length (exhaust) 40.78 mm (1.61 in)
	Limit 38.74 mm (1.53 in)

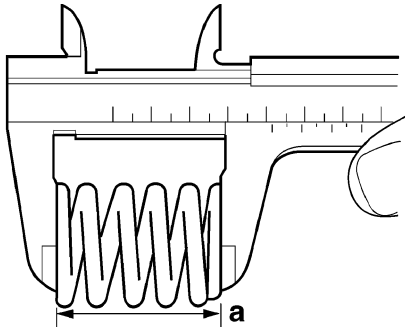

2. Measure:

- Compressed valve spring force “a”
Out of specification → Replace the valve spring.

	Installed compression spring force (intake) 186.00–214.00 N (18.97–21.82 kgf, 41.81–48.11 lbf)
	Installed compression spring force (exhaust) 186.00–214.00 N (18.97–21.82 kgf, 41.81–48.11 lbf)
	Installed length (intake) 33.88 mm (1.33 in)
	Installed length (exhaust) 33.88 mm (1.33 in)

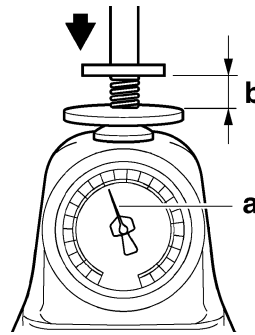

b. Installed length

3. Measure:

- Valve spring tilt “a”
Out of specification → Replace the valve spring.

	Spring tilt (intake) 2.5°/1.8 mm
	Spring tilt (exhaust) 2.5°/1.8 mm

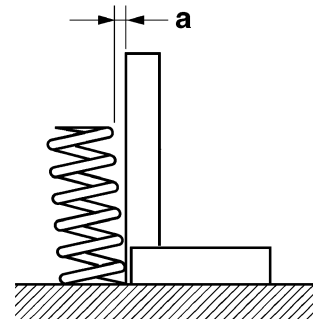

EAS24320

CHECKING THE VALVE LIFTERS

The following procedure applies to all of the valve lifters.

1. Check:

- Valve lifter
Damage/scratches → Replace the valve lifters and cylinder head.

EAS24340

INSTALLING THE VALVES

The following procedure applies to all of the valves and related components.

1. Deburr:

- Valve stem end
(with an oil stone)

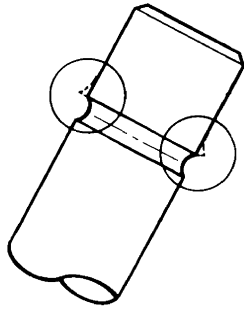

2. Lubricate:

- Valve stem "1"
- Valve stem seal "2"
(with the recommended lubricant)

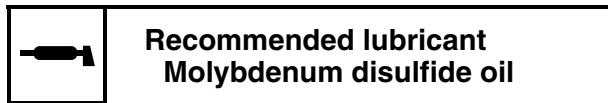

- Valve stem end
(with the recommended lubricant)

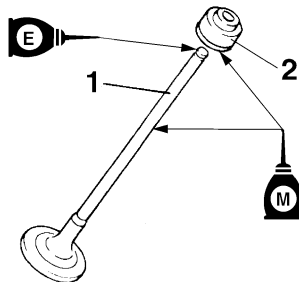

3. Install:

- Valve spring seat "1"
- Valve stem seal "2" **New**
- Valve "3"
- Valve spring "4"
- Valve spring retainer "5"
(into the cylinder head)

TIP

- Make sure each valve is installed in its original place.
- Install the valve springs with the larger pitch "a" facing up.

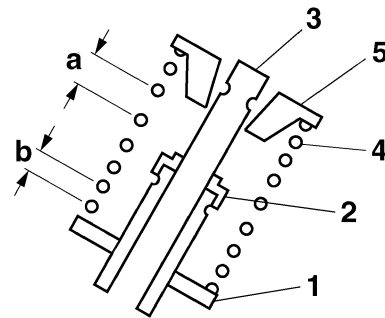
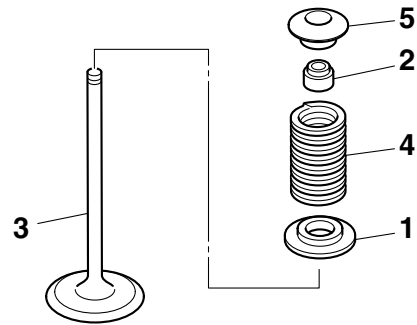

- b. Smaller pitch

4. Install:

- Valve cotteners

TIP

Install the valve cotteners by compressing the valve spring with the valve spring compressor "1" and the valve spring compressor attachment "2".



Valve spring compressor
90890-04019
YM-04019
Valve spring compressor attachment
90890-01243
Valve spring compressor adapter (26 mm)
YM-01253-1

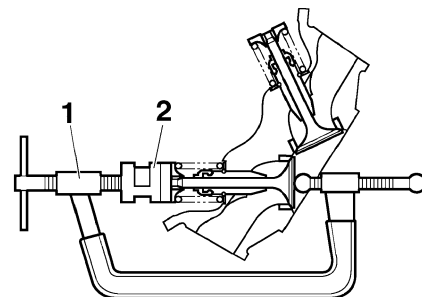

5. To secure the valve cotters onto the valve stem, lightly tap the valve tip with a soft-face hammer.

ECA13800

NOTICE

Hitting the valve tip with excessive force could damage the valve.

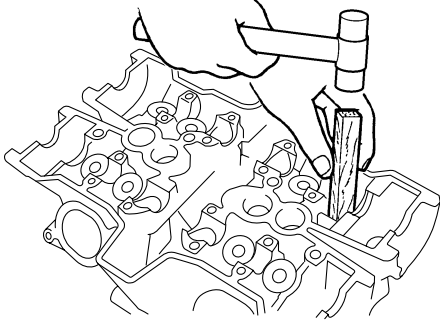

6. Lubricate:
- Valve pad
(with the recommended lubricant)



- Valve lifter
(with the recommended lubricant)



7. Install:
- Valve pad
 - Valve lifter

TIP

- The valve lifter must move smoothly when rotated with a finger.
- Each valve lifter and valve pad must be reinstalled in its original position.

GENERATOR AND STARTER CLUTCH

EAS24480

GENERATOR AND STARTER CLUTCH

Removing the stator coil

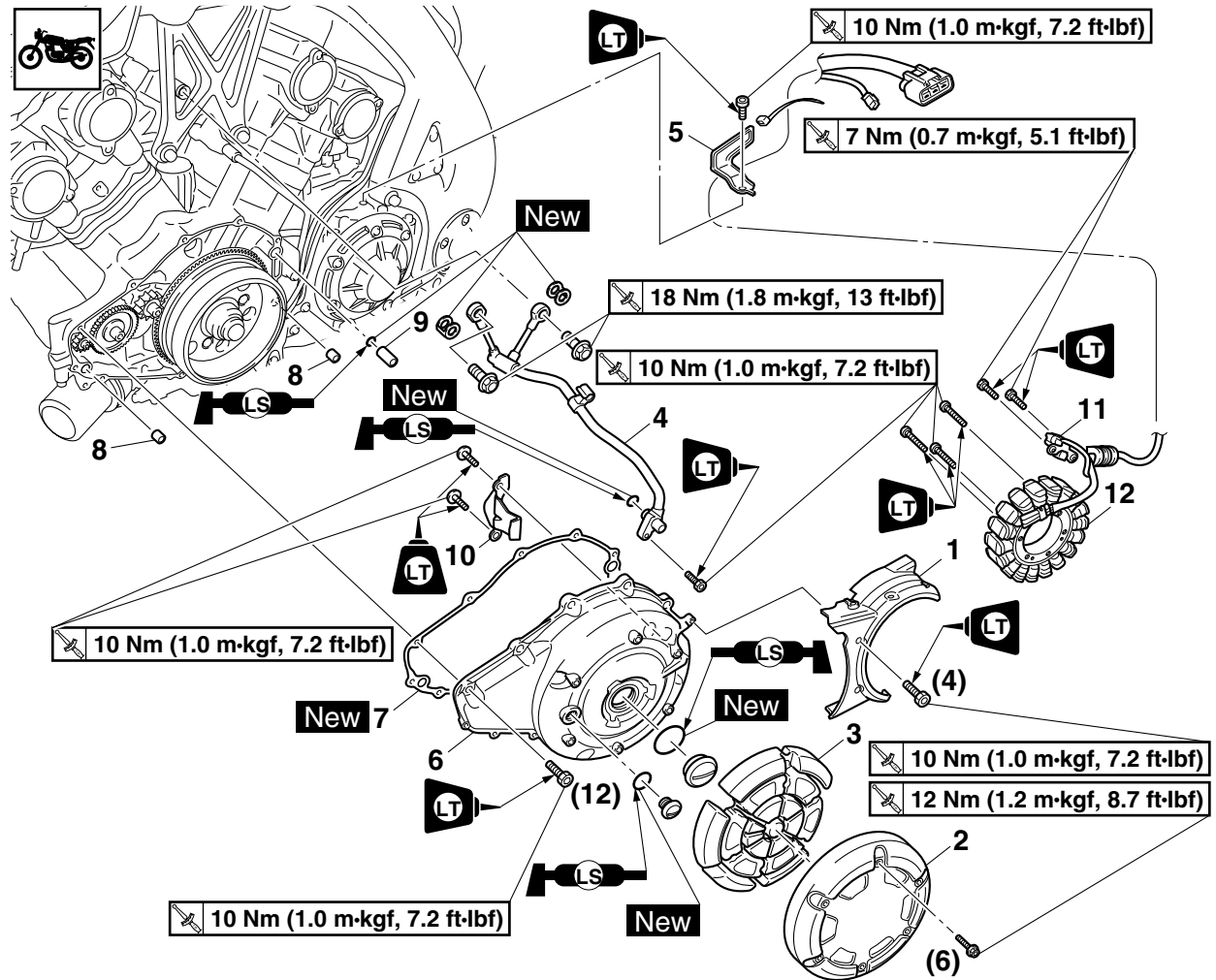

Order	Job/Parts to remove	Q'ty	Remarks
	Front exhaust pipes		Refer to "ENGINE REMOVAL" on page 5-1.
	Fuel tank protector		Refer to "FUEL TANK" on page 7-1.
	Throttle bodies		Refer to "THROTTLE BODIES" on page 7-11.
	Engine oil		Drain. Refer to "CHANGING THE ENGINE OIL" on page 3-11.
1	Clutch release cylinder cover	1	
2	Generator cover plate	1	
3	Generator cover plate damper	1	
4	Oil pipe 1	1	
5	Crankshaft position sensor/stator assembly lead holder 2	1	
6	Generator cover	1	
7	Generator cover gasket	1	
8	Dowel pin	2	
9	Oil nozzle	1	

GENERATOR AND STARTER CLUTCH

Removing the stator coil

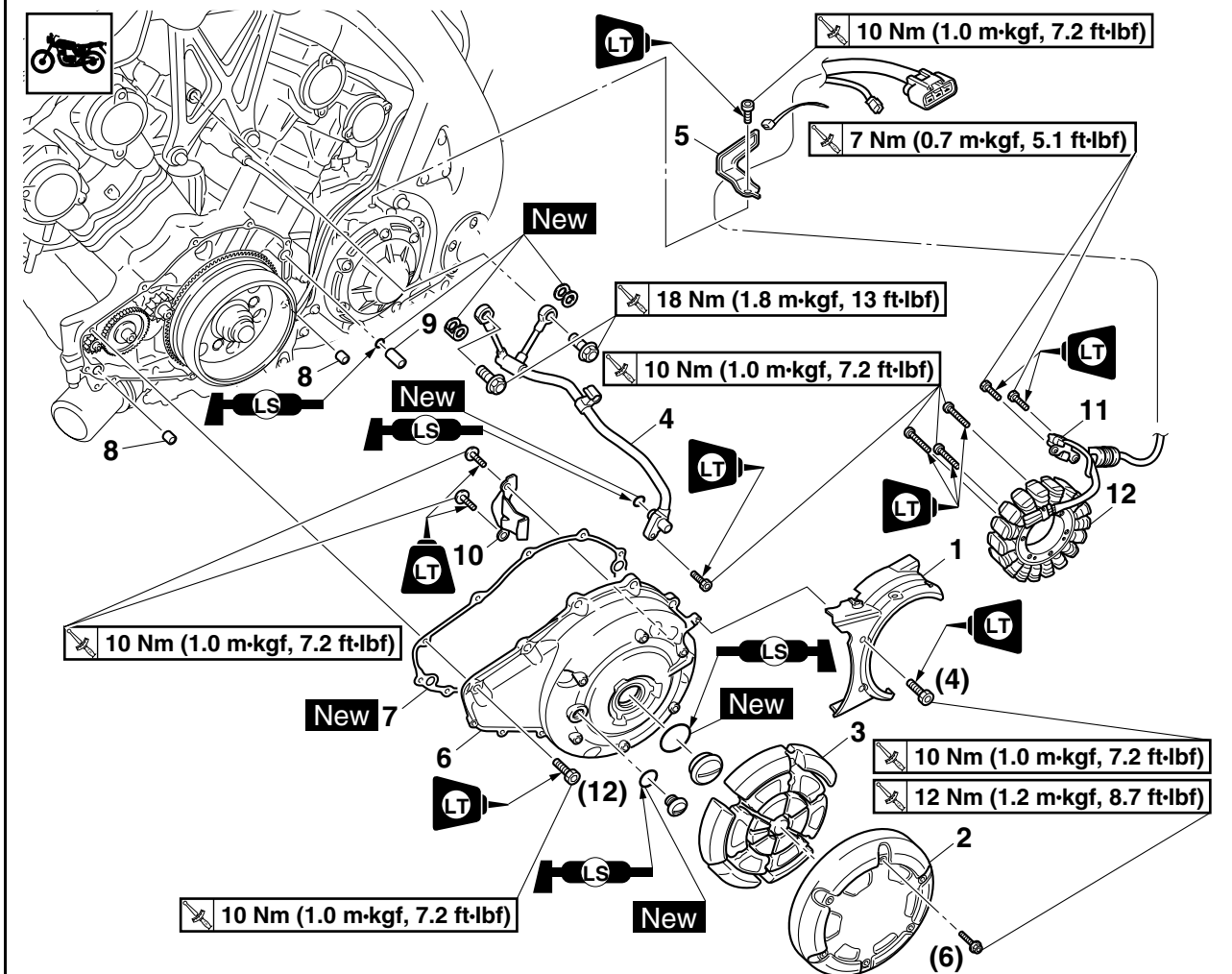

Order	Job/Parts to remove	Q'ty	Remarks
10	Crankshaft position sensor/stator assembly lead holder 1	1	
11	Crankshaft position sensor	1	
12	Stator coil	1	
			For installation, reverse the removal procedure.

GENERATOR AND STARTER CLUTCH

Removing the generator rotor and starter clutch

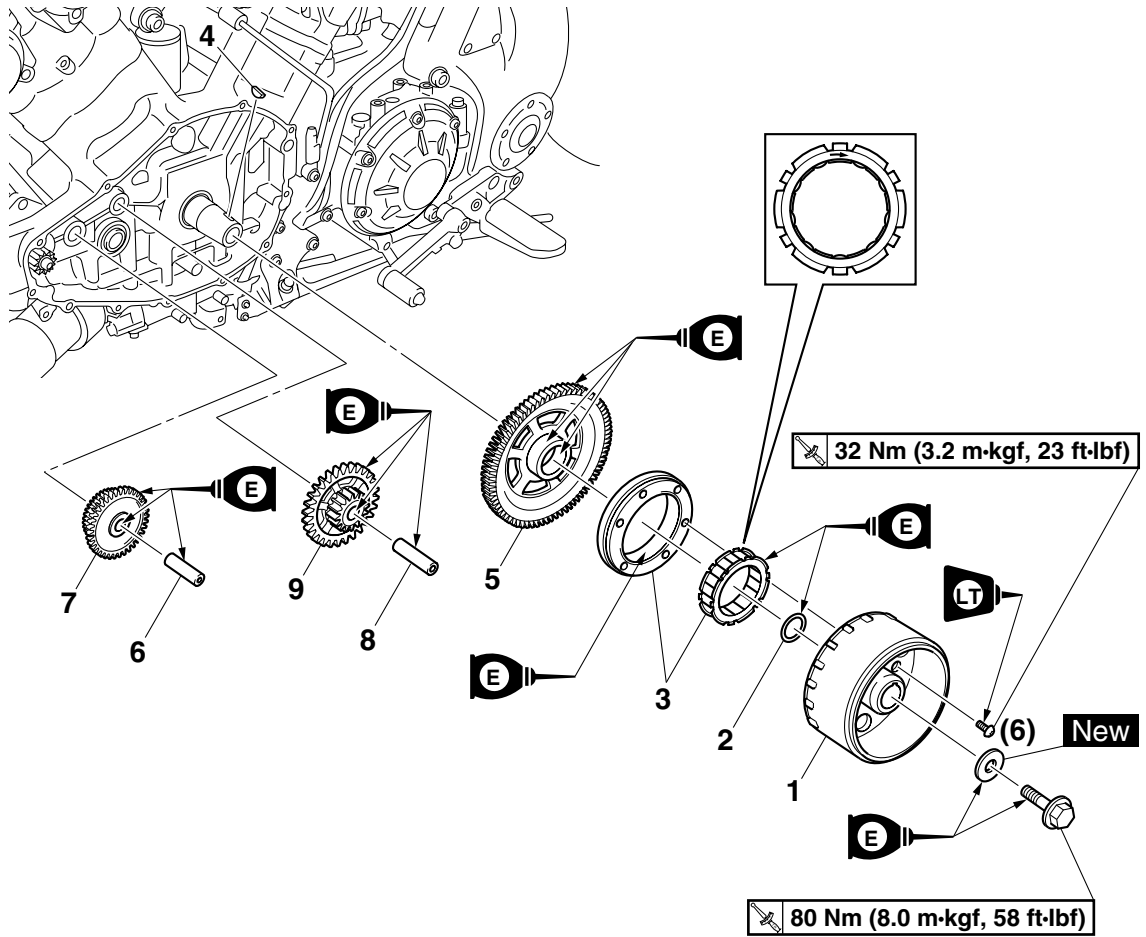

Order	Job/Parts to remove	Q'ty	Remarks
1	Generator rotor	1	
2	Washer	1	
3	Starter clutch	1	
4	Woodruff key	1	
5	Starter clutch gear	1	
6	Starter idle gear shaft	1	
7	Starter idle gear	1	
8	Starter clutch idle gear shaft	1	
9	Starter clutch idle gear	1	
			For installation, reverse the removal procedure.

GENERATOR AND STARTER CLUTCH

EAS24490

REMOVING THE GENERATOR

1. Remove:

- Generator rotor bolt "1"
- Washer
- Starter clutch bolts "2"

TIP

- While holding the generator rotor "3" with the sheave holder "4", loosen the generator rotor bolt and starter clutch bolts.
- Do not allow the sheave holder to touch the projection on the generator rotor.
- Remove every other starter clutch bolt (3 bolts only) to install the flywheel puller.



Sheave holder
90890-01701
Primary clutch holder
YS-01880-A

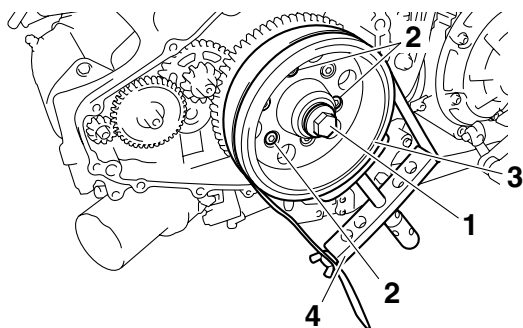

2. Remove:

- Generator rotor "1"
(with the flywheel puller "2")
- Woodruff key

ECA13880

NOTICE

To protect the end of the crankshaft, place an appropriate sized socket between the flywheel puller set center bolt and the crankshaft.

TIP

- Install the flywheel puller bolts to the threaded holes of the starter clutch.
- Make sure the flywheel puller is centered over the generator rotor.



Flywheel puller
90890-01362
Heavy duty puller
YU-33270-B

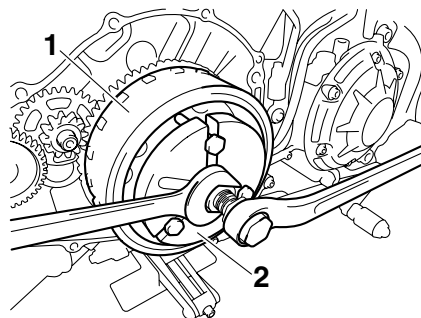

EAS24560

REMOVING THE STARTER CLUTCH

1. Remove:

- Starter clutch bolts
- Starter clutch

TIP

- While holding the generator rotor "1" with the sheave holder "2", remove the starter clutch bolts.
- Do not allow the sheave holder to touch the projection on the generator rotor.



Sheave holder
90890-01701
Primary clutch holder
YS-01880-A

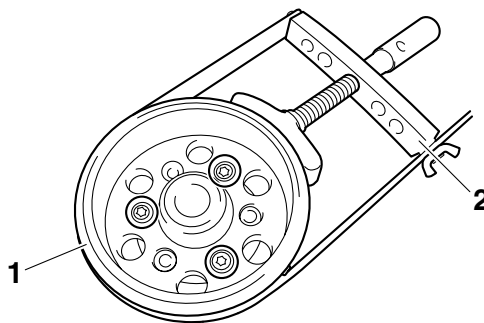

EAS24570

CHECKING THE STARTER CLUTCH

1. Check:

- Starter clutch rollers
Damage/wear → Replace.

2. Check:

- Starter idle gear
- Starter clutch idle gear
- Starter clutch gear
Burrs/chips/roughness/wear → Replace the defective part(s).

3. Check:

- Starter clutch gear's contacting surfaces
Damage/pitting/wear → Replace the starter clutch gear.

GENERATOR AND STARTER CLUTCH



Sheave holder
90890-01701
Primary clutch holder
YS-01880-A

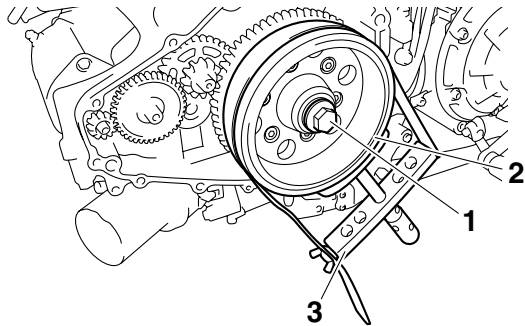

3. Apply:

- Sealant
(onto the crankshaft position sensor/stator assembly lead grommet)



Yamaha bond No. 1215
90890-85505
(Three Bond No.1215®)

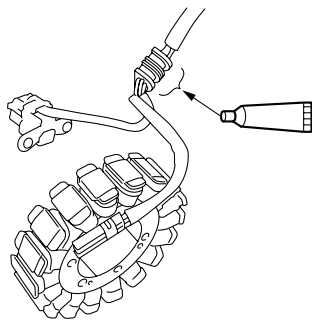

4. Install:

- Stator coil
- Crankshaft position sensor
- Crankshaft position sensor/stator assembly lead holder 1



Stator coil bolt
10 Nm (1.0 m·kgf, 7.2 ft·lbf)
LOCTITE®
Crankshaft position sensor bolt
7 Nm (0.7 m·kgf, 5.1 ft·lbf)
LOCTITE®
Crankshaft position sensor/stator assembly lead holder 1 bolt
10 Nm (1.0 m·kgf, 7.2 ft·lbf)
LOCTITE®

TIP

- Route the crankshaft position sensor lead “1” to the inside of the rib “a” on the generator cover.
- Route the crankshaft position sensor/stator assembly lead holder “b”.
- Make sure that the crankshaft position sensor lead is routed around the generator cover boss “c”.
- Route the stator coil lead “2” to the inside of the rib “d” on the generator cover.

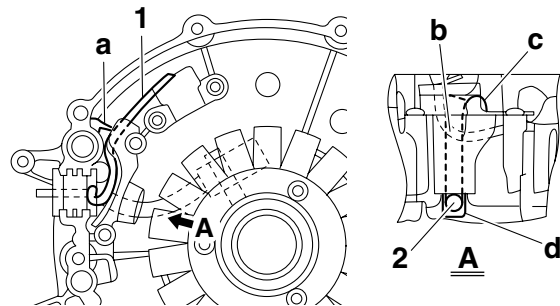

5. Install:

- Generator cover gasket **New**
- Generator cover



Generator cover bolt
10 Nm (1.0 m·kgf, 7.2 ft·lbf)
LOCTITE®

TIP

Tighten the generator cover bolts in stages and in a crisscross pattern.

6. Install:

- Generator cover plate damper
- Generator cover plate “1”



Generator cover plate bolt
12 Nm (1.2 m·kgf, 8.7 ft·lbf)

TIP

- Install the generator cover plate so that the lettering in the recycle mark “a” is right side up.
- Tighten the generator cover plate bolts in stages and in a crisscross pattern.

GENERATOR AND STARTER CLUTCH

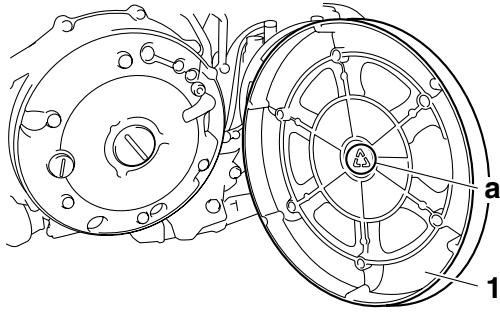

EAS24780

ELECTRIC STARTER

Removing the starter motor

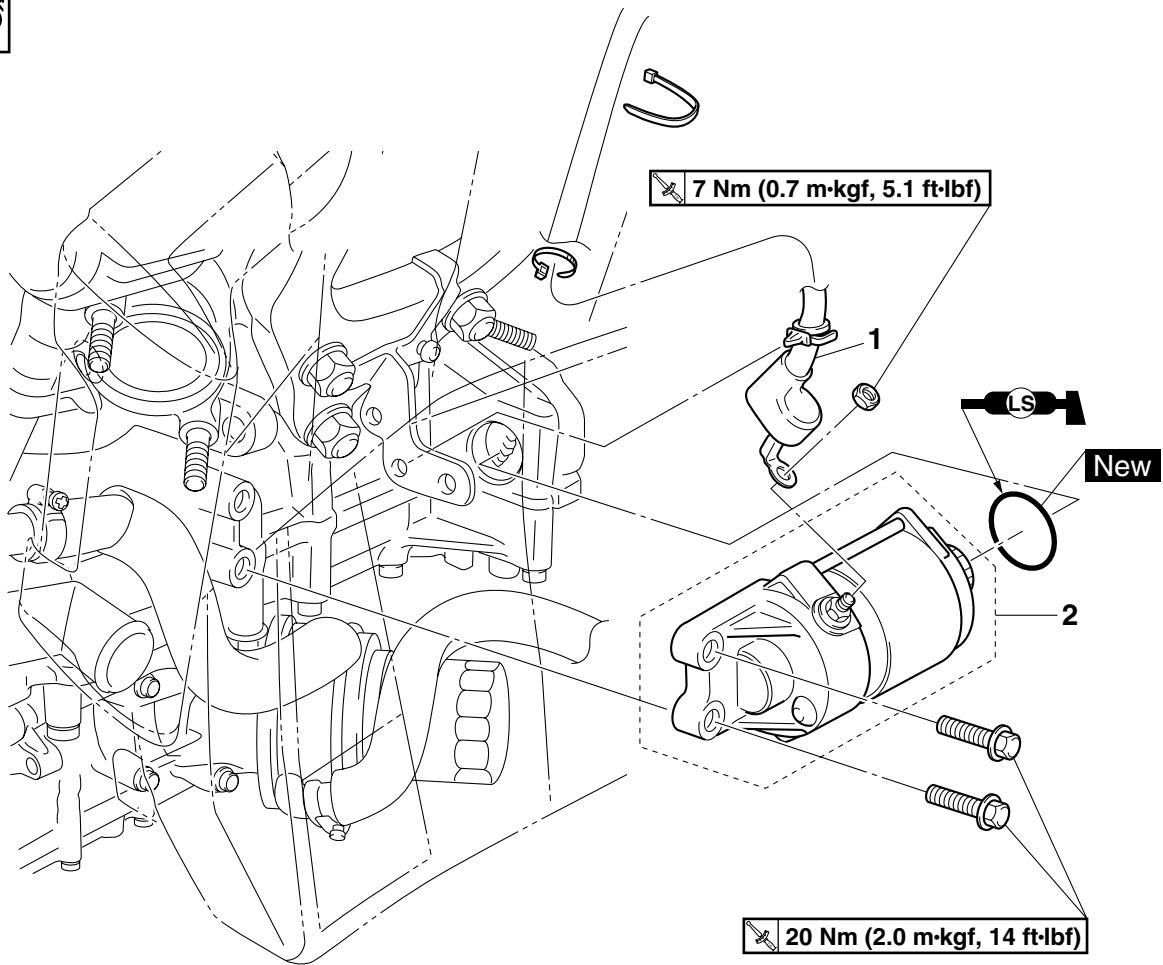

Order	Job/Parts to remove	Q'ty	Remarks
	Front exhaust pipes		Refer to "ENGINE REMOVAL" on page 5-1.
1	Starter motor lead	1	Disconnect.
2	Starter motor assembly	1	
			For installation, reverse the removal procedure.

ELECTRIC STARTER

Disassembling the starter motor

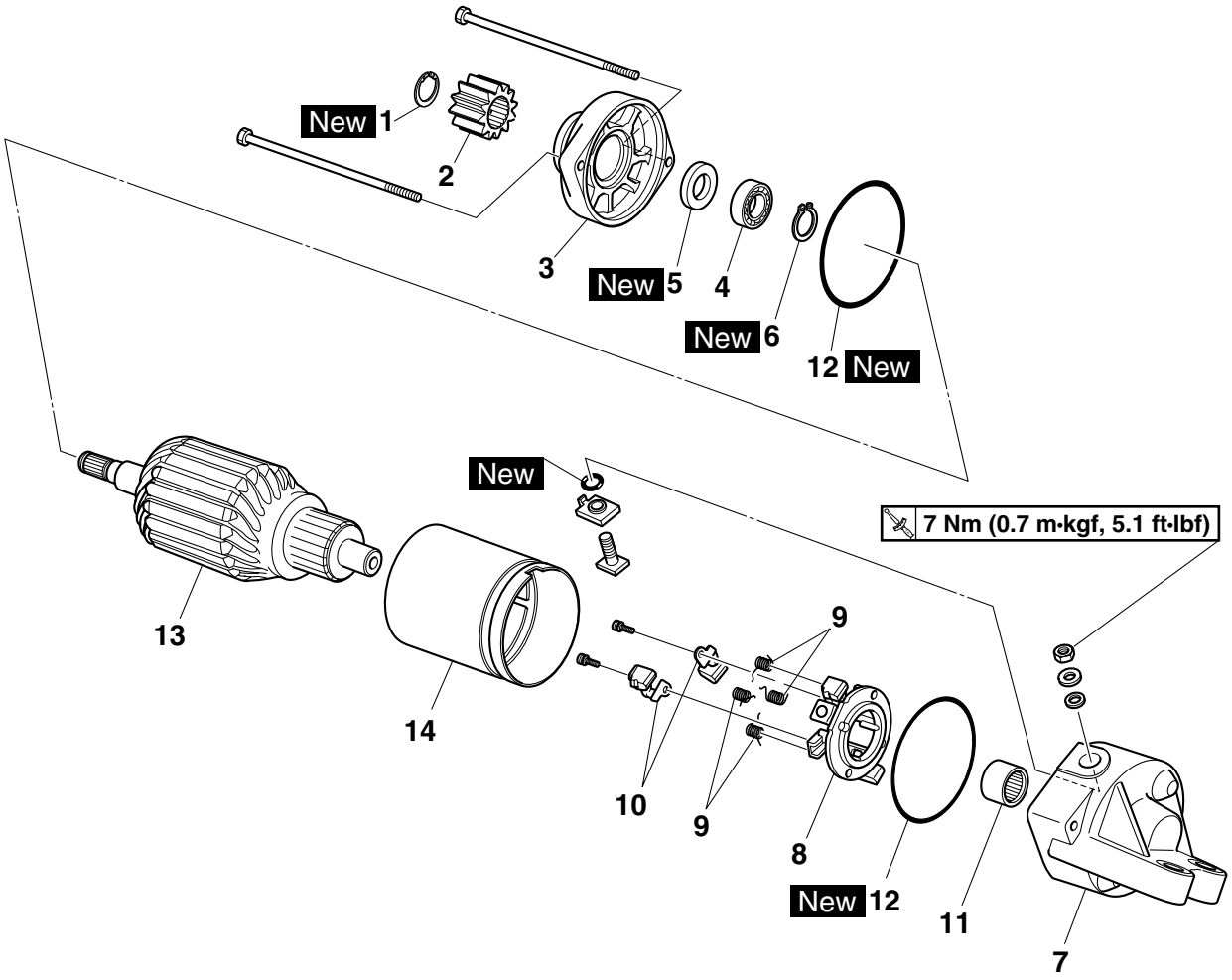

Order	Job/Parts to remove	Q'ty	Remarks
1	Circlip	1	
2	Pinion gear	1	
3	Starter motor front cover	1	
4	Bearing	1	
5	Oil seal	1	
6	Circlip	1	
7	Starter motor rear cover	1	
8	Brush seat (along with brushes)	1	
9	Brush spring	4	
10	Brush	2	
11	Bearing	1	
12	O-ring	2	
13	Armature assembly	1	
14	Starter motor yoke	1	
			For assembly, reverse the disassembly procedure.

EAS24790

CHECKING THE STARTER MOTOR

1. Check:

- Commutator
Dirt → Clean with 600 grit sandpaper.

2. Measure:

- Commutator diameter “a”
Out of specification → Replace the starter motor.



Limit
27.0 mm (1.06 in)

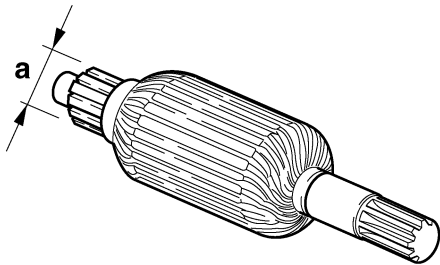

3. Measure:

- Mica undercut “a”
Out of specification → Scrape the mica to the proper measurement with a hacksaw blade that has been grounded to fit the commutator.



Mica undercut (depth)
1.00 mm (0.04 in)

TIP

The mica of the commutator must be undercut to ensure proper operation of the commutator.



4. Measure:

- Armature assembly resistance (commutator and insulation)
Out of specification → Replace the starter motor.

a. Measure the armature assembly resistance with the digital circuit tester.



Digital circuit tester
90890-03174
Model 88 Multimeter with tachometer
YU-A1927



Armature coil
Commutator resistance “1”
Continuity (0.0081–0.0099 Ω at 20 °C (68 °F))
Insulation resistance “2”
No continuity (Above 1 MΩ at 20 °C (68 °F))

b. If any resistance is out of specification, replace the starter motor.

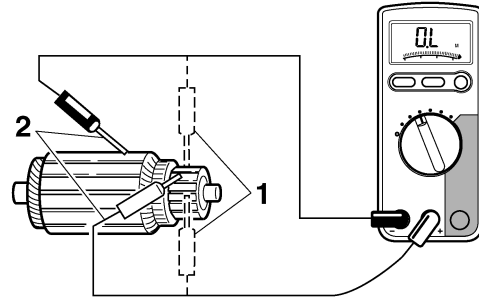

5. Measure:

- Brush length “a”
Out of specification → Replace the brushes as a set.



Limit
7.60 mm (0.30 in)

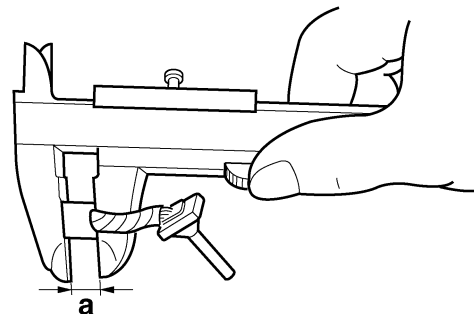

6. Measure:

- Brush spring force
Out of specification → Replace the brush springs as a set.



Brush spring force
7.36–11.04 N (750–1126 gf,
26.49–39.74 oz)

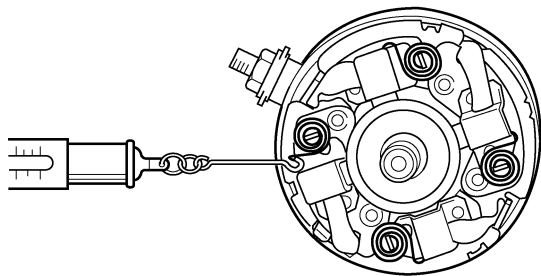

7. Check:

- Pinion gear teeth
Damage/wear → Replace the gear.

8. Check:

- Bearing
- Oil seal
Damage/wear → Replace the defective part(s).

EAS24800

ASSEMBLING THE STARTER MOTOR

1. Install:

- Brush seat "1"

TIP

Align the projection "a" on the starter motor rear cover with the slot "b" in the brush seat.

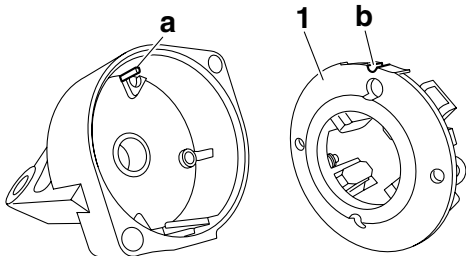

2. Install:

- Starter motor yoke "1"
- Starter motor rear cover "2"

TIP

Align the projection "a" on the starter motor rear cover with the slot "b" in the starter motor yoke.

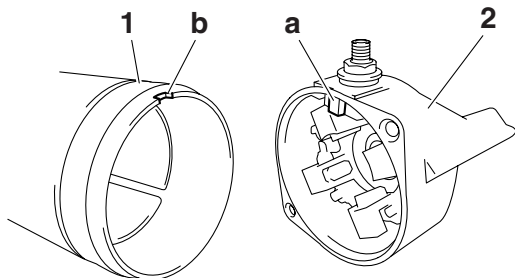

3. Install:

- Starter motor yoke "1"
- Starter motor front cover "2"

TIP

Align the match marks "a" on the starter motor yoke with the match mark "b" on the starter motor front cover.

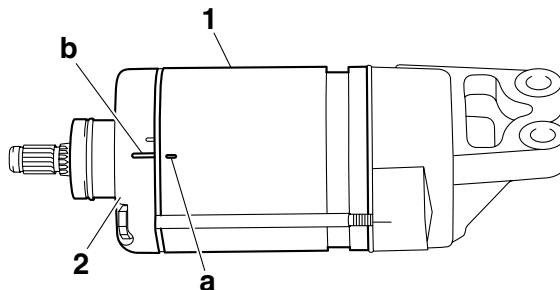

EAS25061

CLUTCH

Removing the clutch cover

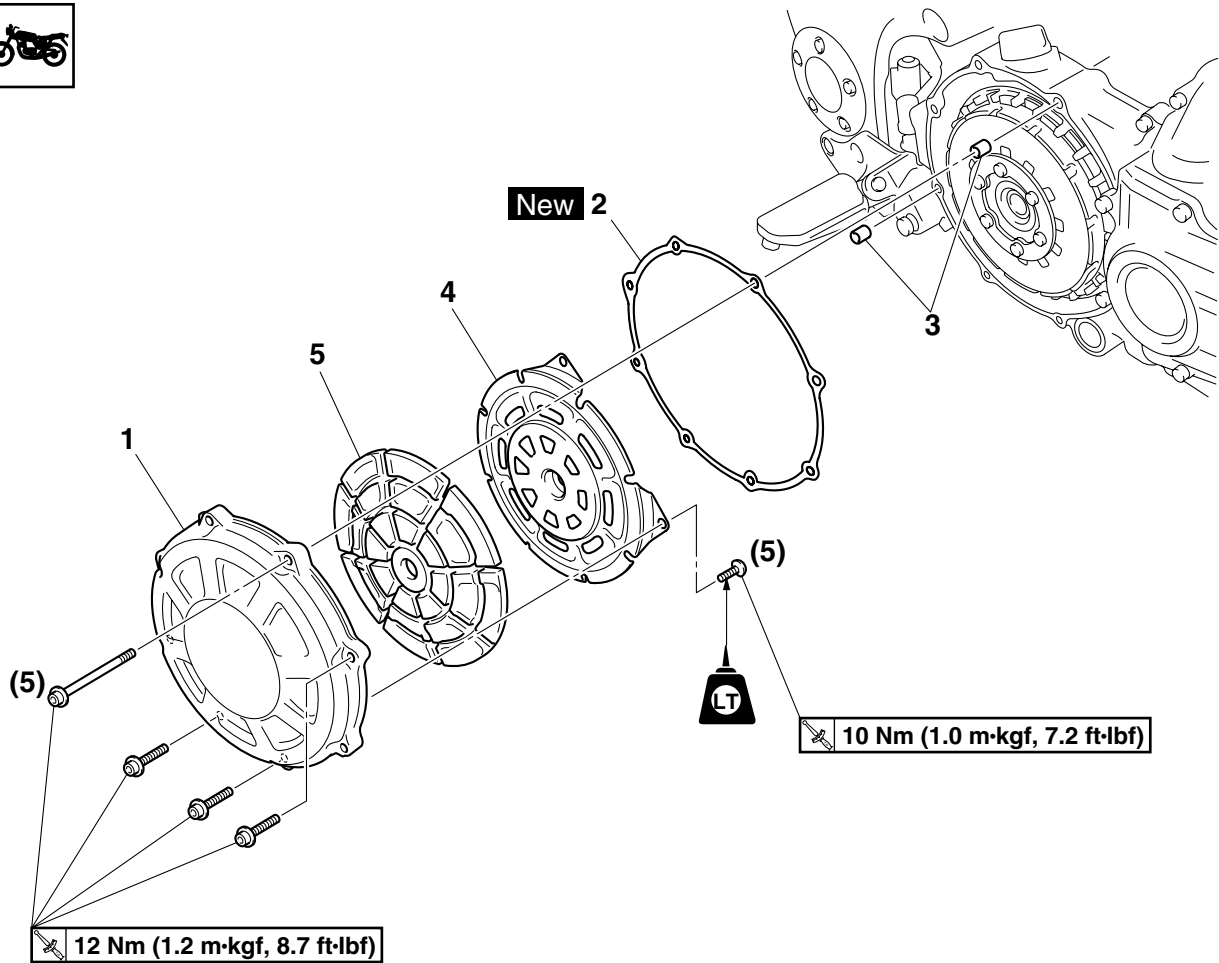

Order	Job/Parts to remove	Q'ty	Remarks
	Engine oil		Drain. Refer to "CHANGING THE ENGINE OIL" on page 3-11.
1	Clutch cover	1	
2	Clutch cover gasket	1	
3	Dowel pin	2	
4	Clutch cover damper plate	1	
5	Clutch cover damper	1	
			For installation, reverse the removal procedure.

Removing the clutch

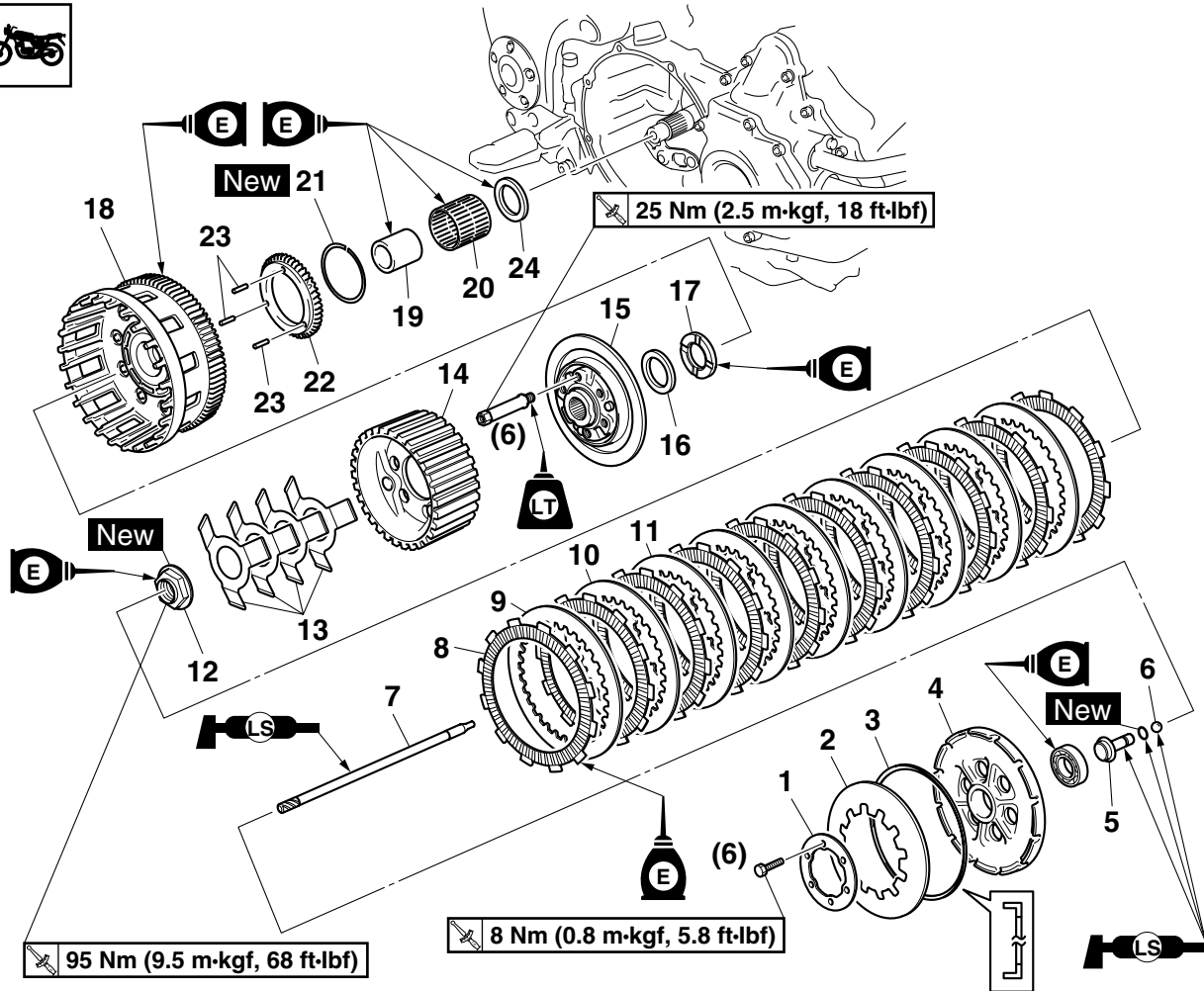

Order	Job/Parts to remove	Q'ty	Remarks
	Clutch release cylinder		Refer to "REMOVING THE CLUTCH RELEASE CYLINDER" on page 5-62.
1	Clutch spring plate retainer	1	
2	Clutch spring plate	1	
3	Clutch spring plate seat	1	
4	Pressure plate	1	
5	Short clutch push rod	1	
6	Ball	1	
7	Long clutch push rod	1	
8	Friction plate	10	
9	Clutch plate 1	1	
10	Clutch plate 2	1	
11	Clutch plate 3	7	
12	Clutch boss nut	1	
13	Spring	4	
14	Clutch boss	1	
15	Clutch boss plate	1	
16	Conical spring washer	1	

Removing the clutch

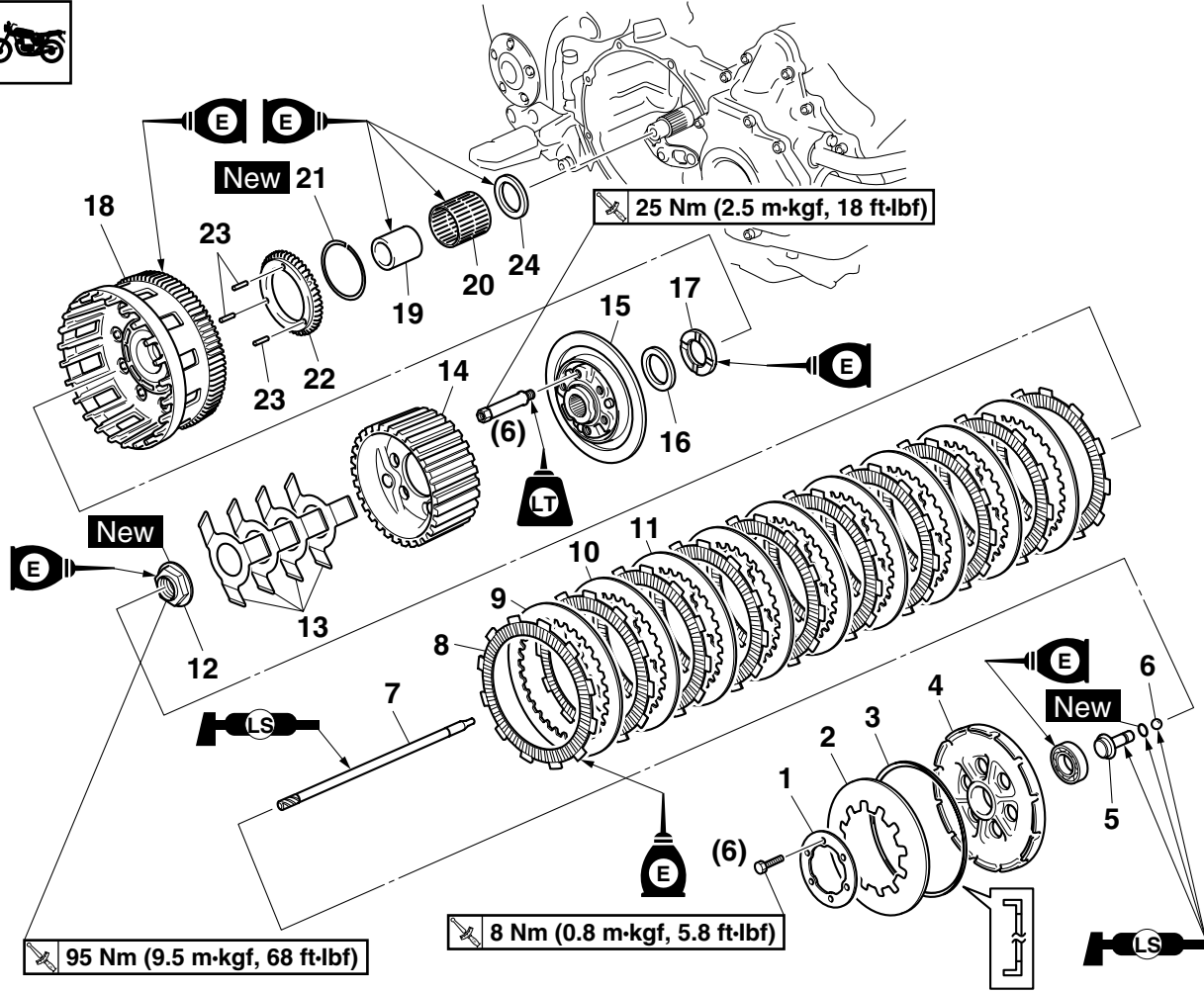

Order	Job/Parts to remove	Q'ty	Remarks
17	Thrust washer	1	
18	Clutch housing	1	
19	Collar	1	
20	Bearing	1	
21	Circlip	1	
22	Oil pump drive gear	1	
23	Dowel pin	3	
24	Thrust washer	1	
			For installation, reverse the removal procedure.

Removing the clutch master cylinder

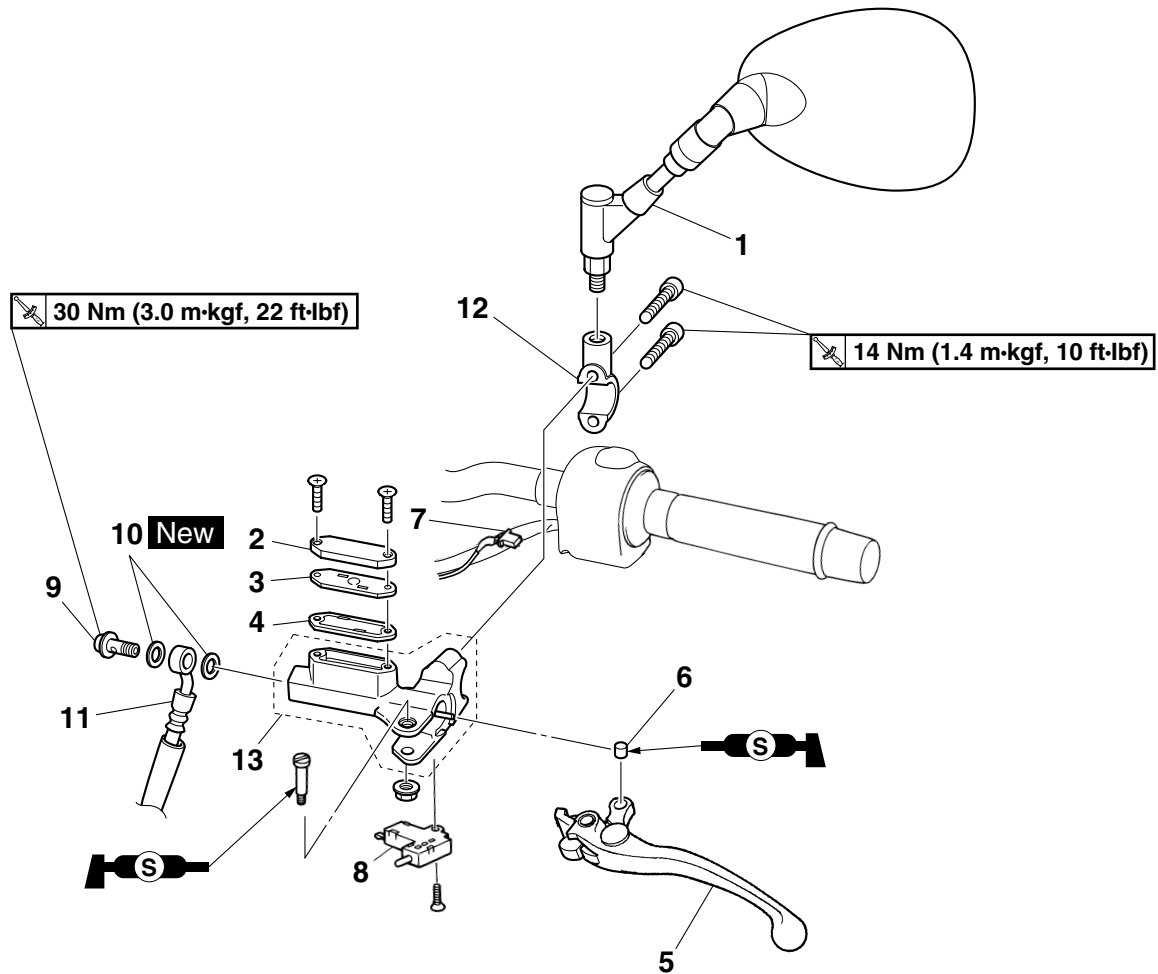

Order	Job/Parts to remove	Q'ty	Remarks
	Clutch fluid		Drain. Refer to "BLEEDING THE HYDRAULIC CLUTCH SYSTEM" on page 3-13.
1	Left rearview mirror	1	
2	Clutch master cylinder reservoir cap	1	
3	Clutch master cylinder reservoir diaphragm holder	1	
4	Clutch master cylinder reservoir diaphragm	1	
5	Clutch lever	1	
6	Bushing	1	
7	Clutch switch coupler	1	Disconnect.
8	Clutch switch	1	
9	Clutch hose union bolt	1	
10	Clutch hose gasket	2	
11	Clutch hose	1	Disconnect.
12	Clutch master cylinder holder	1	

Removing the clutch master cylinder

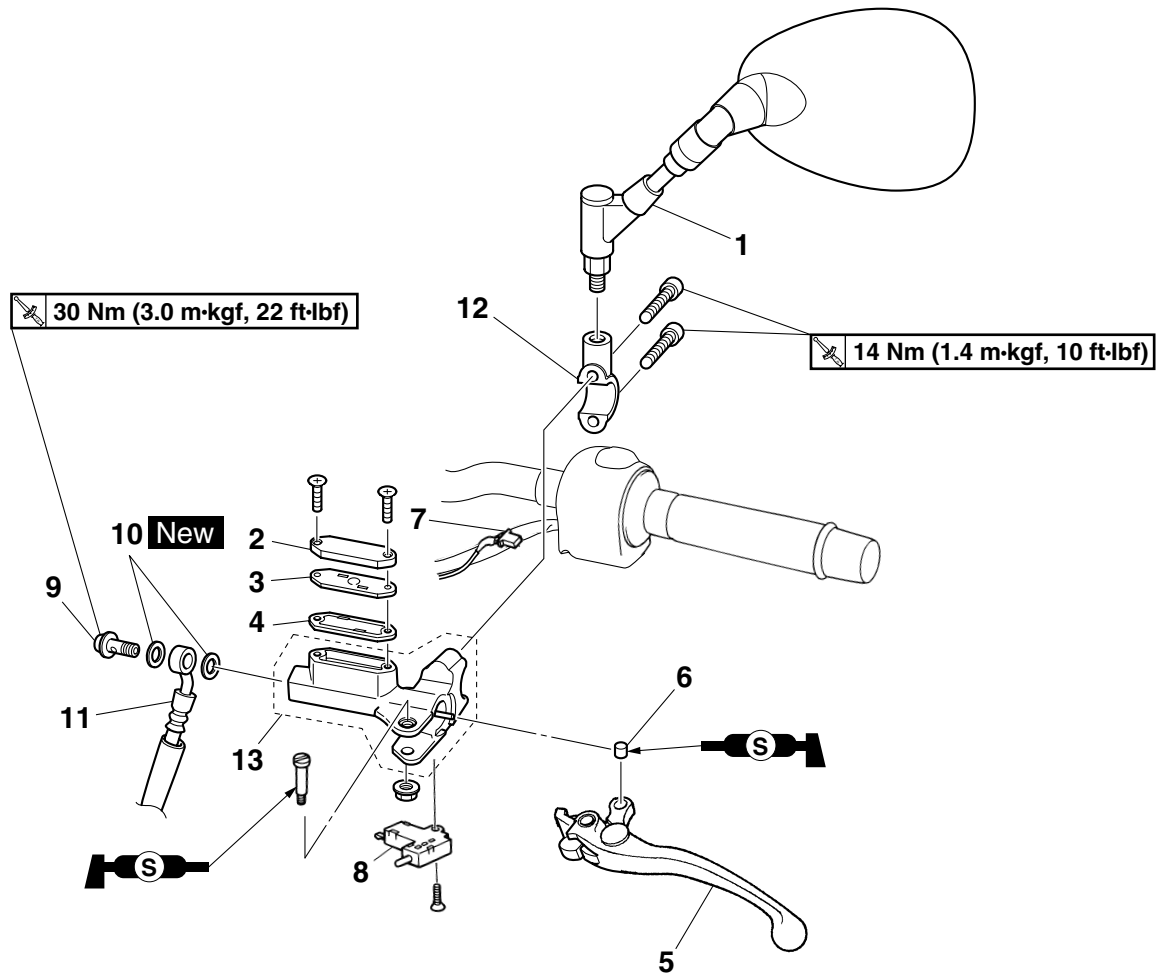

Order	Job/Parts to remove	Q'ty	Remarks
13	Clutch master cylinder	1	
			For installation, reverse the removal procedure.

Disassembling the clutch master cylinder

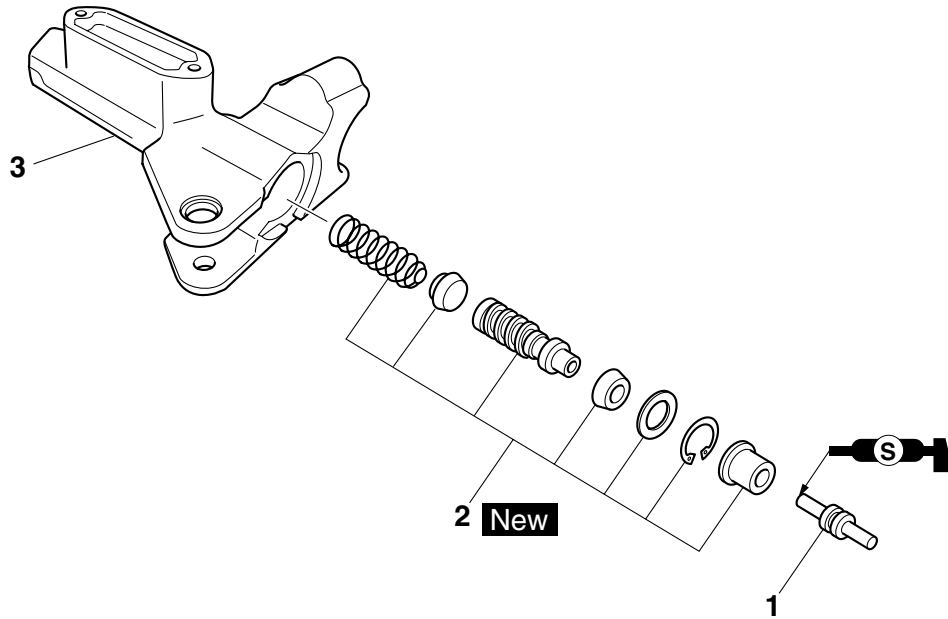

Order	Job/Parts to remove	Q'ty	Remarks
1	Clutch master cylinder push rod	1	
2	Clutch master cylinder kit	1	
3	Clutch master cylinder body	1	
			For assembly, reverse the disassembly procedure.

Removing the clutch release cylinder

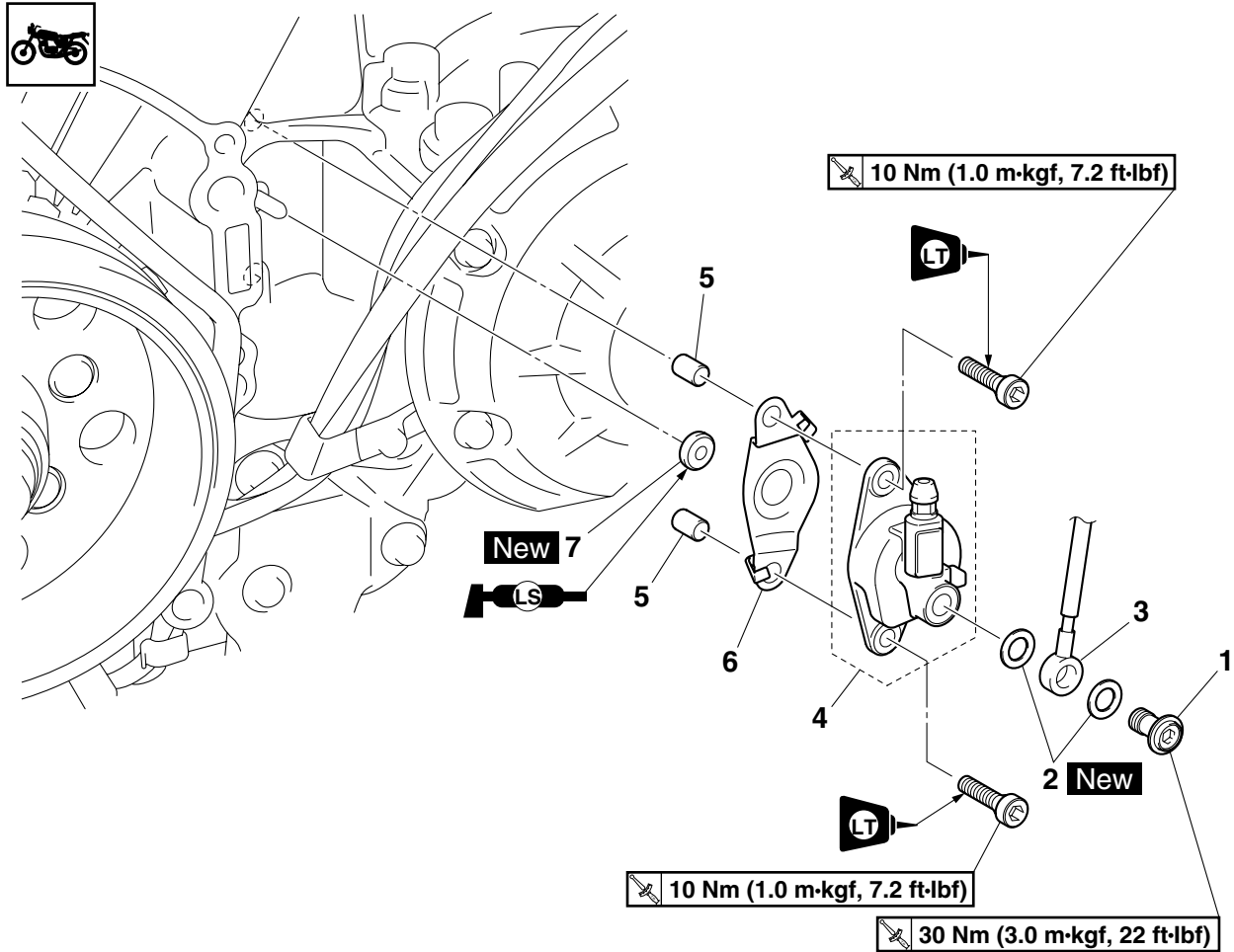

Order	Job/Parts to remove	Q'ty	Remarks
	Clutch fluid		Drain. Refer to "BLEEDING THE HYDRAULIC CLUTCH SYSTEM" on page 3-13.
	Generator cover		Refer to "GENERATOR AND STARTER CLUTCH" on page 5-37.
1	Clutch hose union bolt	1	
2	Clutch hose gasket	2	
3	Clutch hose	1	Disconnect.
4	Clutch release cylinder	1	
5	Dowel pin	2	
6	Clutch release cylinder plate	1	
7	Oil seal	1	
			For installation, reverse the removal procedure.

Disassembling the clutch release cylinder

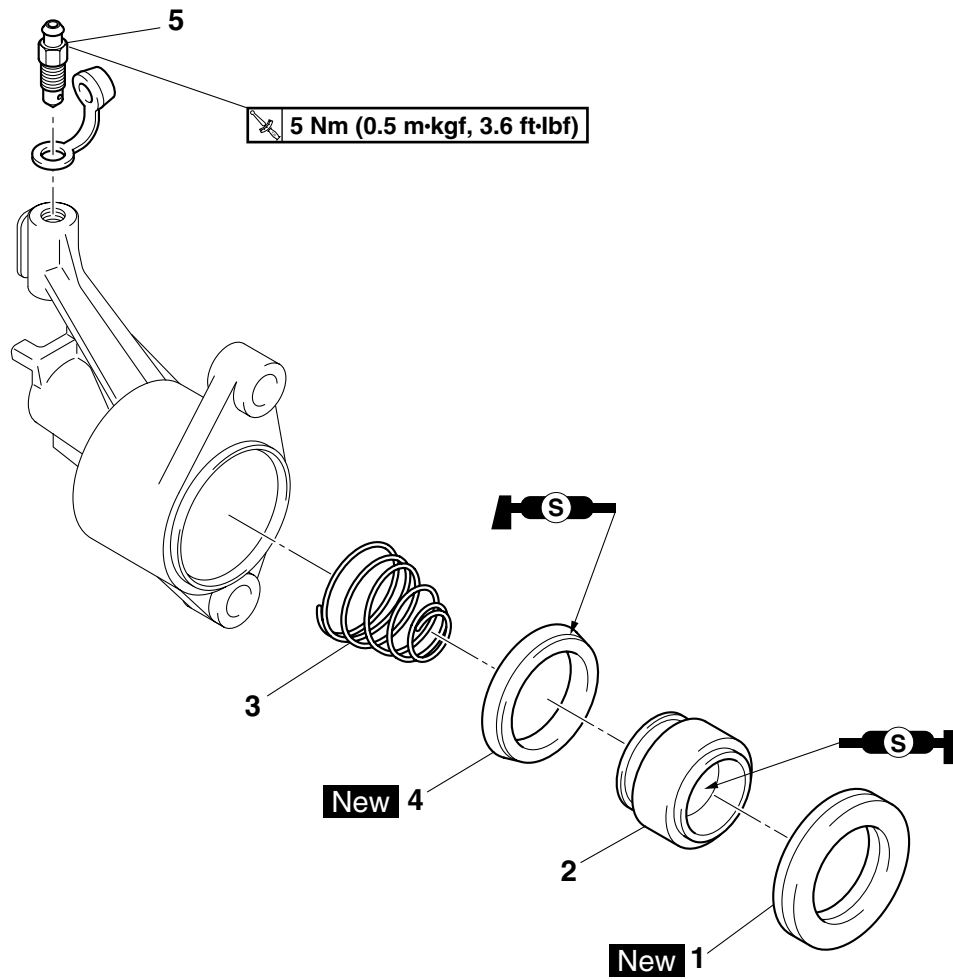

Order	Job/Parts to remove	Q'ty	Remarks
1	Boot	1	
2	Clutch release cylinder piston	1	
3	Clutch release cylinder spring	1	
4	Clutch release cylinder piston seal	1	
5	Bleed screw	1	
			For assembly, reverse the disassembling procedure.

EAS25070

REMOVING THE CLUTCH

1. Remove:

- Clutch cover “1”

TIP

Loosen each bolt 1/4 of a turn at a time, in stages and in a crisscross pattern. After all of the bolts are fully loosened, remove them.

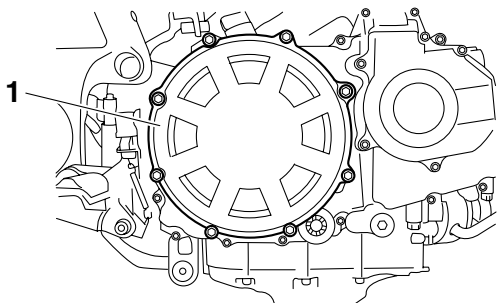

2. Remove:

- Clutch spring plate retainer “1”
- Clutch spring plate “2”
- Clutch spring plate retainer bolts

TIP

Loosen the clutch spring plate retainer bolts in stages and in a crisscross pattern.

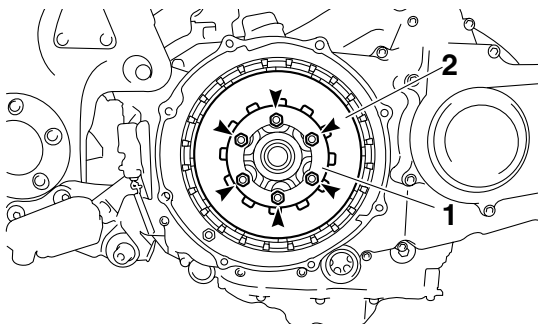

3. Remove:

- Long clutch push rod “1”

TIP

Push the long clutch push rod into the clutch release cylinder side of the engine, and remove it from the clutch side of the engine.

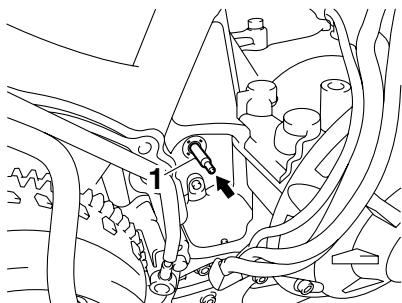

4. Loosen:

- Clutch boss nut “1”

TIP

While holding the clutch boss “2” with the universal clutch holder “3”, loosen the clutch boss nut.



Universal clutch holder
90890-04086
YM-91042

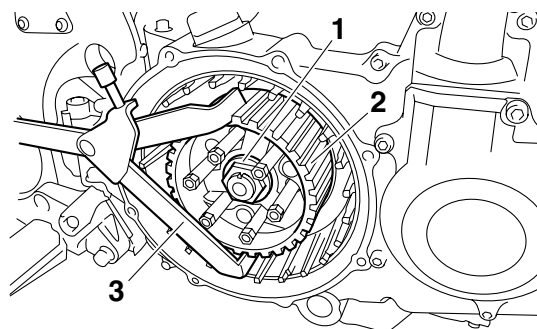

EAS25100

CHECKING THE FRICTION PLATES

The following procedure applies to all of the friction plates.

1. Check:

- Friction plate
Damage/wear → Replace the friction plates as a set.

2. Measure:

- Friction plate thickness
Out of specification → Replace the friction plates as a set.

TIP

Measure the friction plate at four places.



Friction plate thickness
2.92–3.08 mm (0.115–0.121 in)
Wear limit
2.80 mm (0.1102 in)

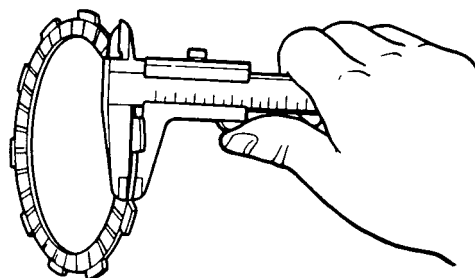

EAS25110

CHECKING THE CLUTCH PLATES

The following procedure applies to all of the clutch plates.

1. Check:
 - Clutch plate
Damage → Replace the clutch plates as a set.
2. Measure:
 - Clutch plate warpage
(with a surface plate and thickness gauge "1")
Out of specification → Replace the clutch plates as a set.



Thickness gauge
90890-03180
Feeler gauge set
YU-26900-9



Clutch plate thickness
1.90–2.10 mm (0.075–0.083 in)
Warpage limit
0.10 mm (0.0039 in)

TIP

The clutch plate thickness specification listed above is for the plates with the standard thickness only. If a clutch plate with one of the other two plate thicknesses is installed, use 1.50–1.70 mm (0.059–0.067 in) or 2.50–2.70 mm (0.098–0.106 in) for the specification according to the plate.

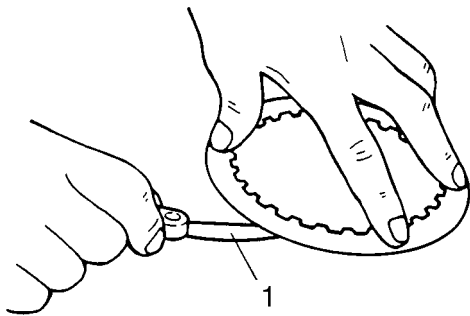

3. Measure:
 - Total width "a" of the friction plates and clutch plates
Out of specification → Adjust.



Total width of the friction plates and clutch plates
45.5–46.1 mm (1.79–1.81 in)

TIP

- This step should be performed only if the friction plates and clutch plates were replaced.
- To measure the total width of the friction plates and clutch plates, combine 9 friction plates and 9 clutch plates as shown.

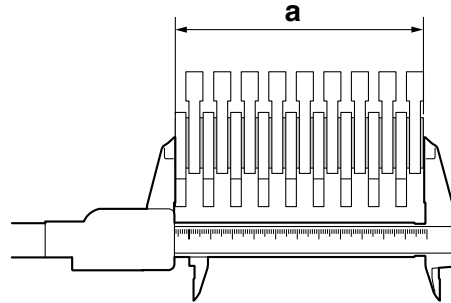

- a. Adjust the total width by replacing the clutch plate "1" and, if necessary, clutch plate "2".
- b. Select the clutch plate from the following table.

Clutch plate "1"		
Part No.	Thickness	
47X-16324-00	1.6 mm (0.063 in)	
2H7-16325-00	2.0 mm (0.079 in)	STD
2H7-16324-00	2.6 mm (0.102 in)	

Clutch plate "2"		
Part No.	Thickness	
2H7-16325-00	2.0 mm (0.079 in)	STD
2H7-16324-00	2.6 mm (0.102 in)	

TIP

When adjusting the clutch assembly width (by replacing the clutch plate(s)), be sure to replace the clutch plate "1" first. After replacing the clutch plate "1", if specifications cannot be met, replace the clutch plate "2".

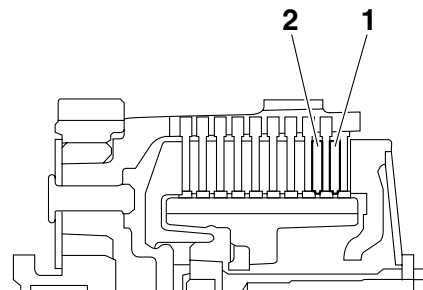

EAS25130

CHECKING THE CLUTCH SPRING PLATE

1. Check:
 - Clutch spring plate
Damage → Replace.
2. Check:
 - Clutch spring plate seat
Damage → Replace.
3. Measure:
 - Clutch spring free height
Out of specification → Replace the clutch spring plate.



Clutch spring height
6.88 mm (0.27 in)
Minimum height
6.38 mm (0.25 in)

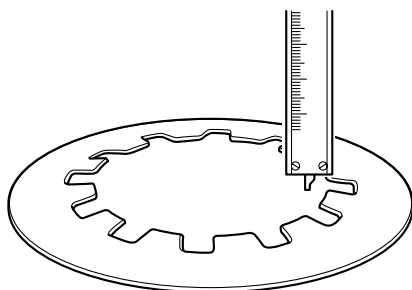

EAS25150

CHECKING THE CLUTCH HOUSING

1. Check:
 - Clutch housing dogs
Damage/pitting/wear → Deburr the clutch housing dogs or replace the clutch housing.

TIP

Pitting on the clutch housing dogs will cause erratic clutch operation.

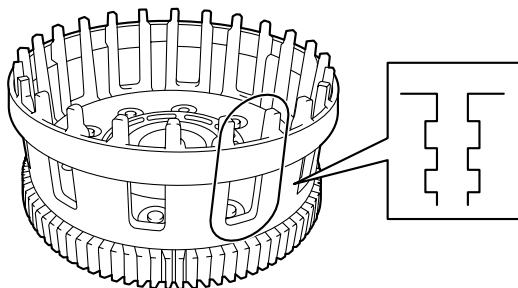

2. Check:
 - Bearing
Damage/wear → Replace.

EAS25160

CHECKING THE CLUTCH BOSS

1. Check:
 - Clutch boss splines
Damage/pitting/wear → Replace the clutch boss.

TIP

Pitting on the clutch boss splines will cause erratic clutch operation.

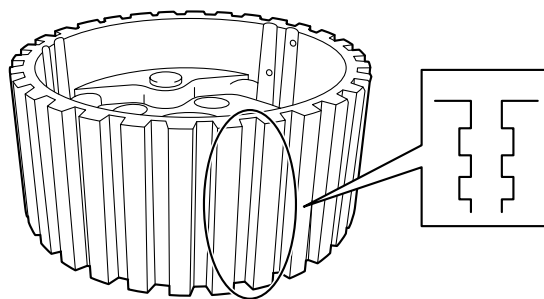

EAS25170

CHECKING THE PRESSURE PLATE

1. Check:
 - Pressure plate
Cracks/damage → Replace.
 - Bearing
Damage/wear → Replace.

EAS25190

CHECKING THE CLUTCH PUSH RODS

1. Check:
 - O-ring
 - Short clutch push rod
 - Long clutch push rod
 - Ball
Cracks/damage/wear → Replace the defective part(s).
2. Measure:
 - Long clutch push rod bending limit
Out of specification → Replace.



Long clutch push rod bending limit
0.370 mm (0.0146 in)

EAS25210

CHECKING THE PRIMARY DRIVEN GEAR

1. Check:
 - Primary driven gear "1"
Damage/wear → Replace the primary drive and primary driven gears as a set.
Excessive noise during operation → Replace the clutch housing and crankshaft as a set.

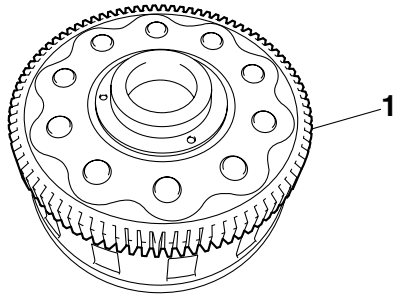

EAS25260

INSTALLING THE CLUTCH

1. Install:

- Clutch boss plate "1"
- Clutch boss "2"

TIP

Assemble the clutch boss and clutch boss plate so that the rivets "a" in the clutch boss are aligned with the notches "b" in the clutch boss plate.

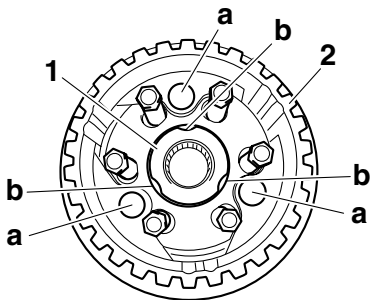

2. Install:

- Clutch boss "1"
- Springs
- Clutch boss nut "2" **New**



Clutch boss nut
95 Nm (9.5 m·kgf, 68 ft·lbf)

TIP

- Lubricate the clutch boss nut threads with engine oil.
- While holding the clutch boss with the universal clutch holder "3", tighten the clutch boss nut.
- Stake the clutch boss nut at a cutout "a" in the main axle.



Universal clutch holder
90890-04086
YM-91042

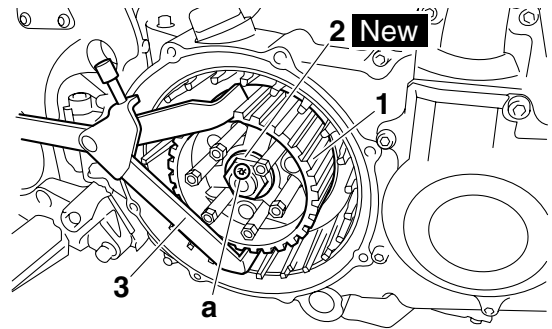

3. Lubricate:

- Friction plates
- Clutch plates
(with the recommended lubricant)



4. Install:

- Friction plates
- Clutch plates

TIP

- First, install a friction plate and then alternate between a clutch plate and a friction plate.
- Install the last friction plate "1" offset from the other friction plates "2", making sure to align a projection on the friction plate with the punch mark "a" on the clutch housing.

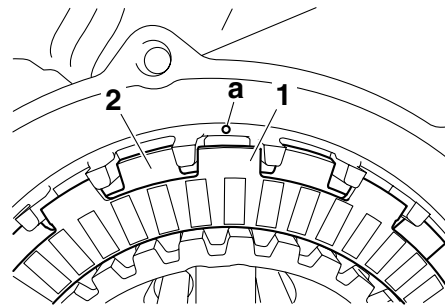

5. Install:

- Clutch spring plate "1"
- Clutch spring plate retainer "2"



Clutch spring plate retainer bolt
8 Nm (0.8 m·kgf, 5.8 ft·lbf)

TIP

Tighten the clutch spring plate retainer bolts in stages and in a crisscross pattern.

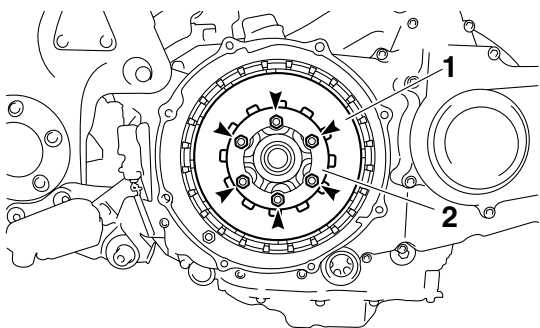

6. Install:

- Clutch cover damper "1"
- Clutch cover damper plate "2"



Clutch cover damper plate bolt
10 Nm (1.0 m·kgf, 7.2 ft·lbf)
LOCTITE®

TIP

Align the arrow mark "a" on the clutch cover 3 with the arrow mark "b" on the clutch cover damper and the arrow mark "c" on the clutch cover damper plate.

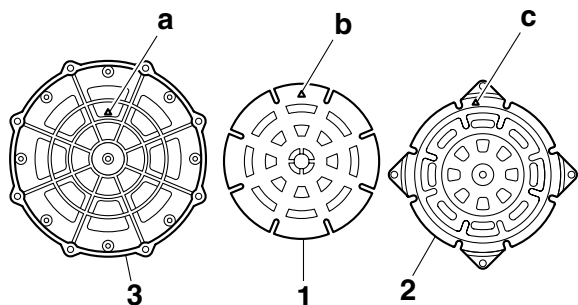

7. Install:

- Clutch cover "1"



Clutch cover bolt
12 Nm (1.2 m·kgf, 8.7 ft·lbf)

TIP

Tighten the clutch cover bolts in stages and in a crisscross pattern.

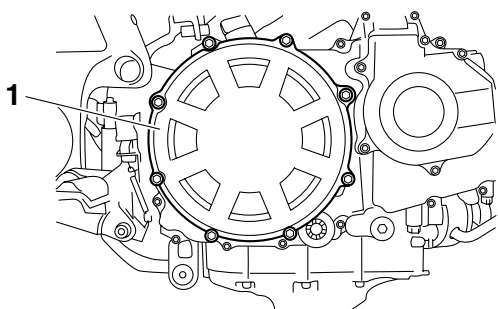

EAS25280

DISASSEMBLING THE CLUTCH MASTER CYLINDER

ECA13840

NOTICE

- Clutch components rarely require disassembly.
- Therefore, always follow these preventive measures:
- Never disassemble clutch components unless absolutely necessary.
- If any connection on the hydraulic clutch system is disconnected, the entire clutch system must be disassembled, drained, cleaned, properly filled, and bled after reassembly.
- Never use solvents on internal clutch components.
- Use only clean or new clutch fluid for cleaning clutch components.
- Clutch fluid may damage painted surfaces and plastic parts. Therefore, always clean up any spilt fluid immediately.
- Avoid clutch fluid coming into contact with the eyes as it can cause serious injury.
- First aid for clutch fluid entering the eyes:
- Flush with water for 15 minutes and get immediate medical attention.

TIP

Before disassembling the clutch master cylinder, drain the clutch fluid from the entire clutch system.

1. Remove:

- Clutch hose union bolt "1"
- Clutch hose gasket "2"
- Clutch hose "3"

TIP

To collect any remaining clutch fluid, place a container under the master cylinder and the end of the clutch hose.

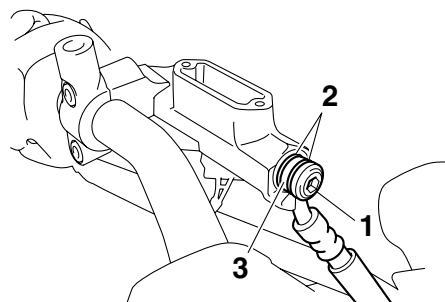

EAS25290

CHECKING THE CLUTCH MASTER CYLINDER

Recommended clutch component replacement schedule	
Piston seals	Every two years
Clutch hose	Every four years
Clutch fluid	Every two years and whenever the clutch is disassembled

1. Check:
 - Clutch master cylinder body
Cracks/damage → Replace.
 - Clutch fluid delivery passage (clutch master cylinder body)
Obstruction → Blow out with compressed air.
2. Check:
 - Clutch master cylinder kit
Rust/scratches/wear → Replace.
3. Check:
 - Clutch master cylinder reservoir
Cracks/damage → Replace.
 - Clutch master cylinder reservoir diaphragm
Damage/wear → Replace.
4. Check:
 - Clutch hose
Cracks/damage/wear → Replace.

EAS25300

ASSEMBLING THE CLUTCH MASTER CYLINDER

EWA13340

WARNING

- Before installation, all internal clutch components must be cleaned and lubricated with clean or new clutch fluid.
- Never use solvents on internal clutch components as they will cause the piston seals to swell and distort.
- Whenever a clutch master cylinder is disassembled, replace the piston seals.



**Recommended fluid
DOT 4**

EAS25310

INSTALLING THE CLUTCH MASTER CYLINDER

1. Install:
 - Clutch master cylinder “1”
 - Clutch master cylinder holder “2”



**Clutch master cylinder holder
bolt
14 Nm (1.4 m·kgf, 10 ft·lbf)**

TIP

- Align the end of the clutch master cylinder holder with the punch mark “a” on the handlebar.
- First, tighten the upper bolt, then the lower bolt.

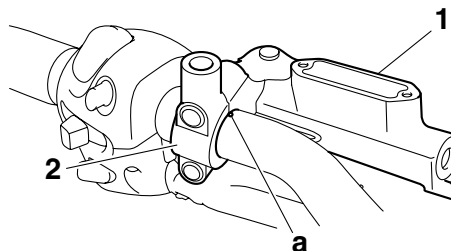

2. Install:

- Clutch hose gasket “1” **New**
- Clutch hose “2”
- Clutch hose union bolt “3”



**Clutch hose union bolt
30 Nm (3.0 m·kgf, 22 ft·lbf)**

EWA13360

WARNING

Proper clutch hose routing is essential to insure safe motorcycle operation. Refer to “CABLE ROUTING” on page 2-47.

ECA2S31065

NOTICE

When installing the clutch hose onto the clutch master cylinder, make sure the clutch pipe “a” touches the projection “b” as shown.

TIP

Turn the handlebars to the left and to the right to make sure the clutch hose does not touch other parts (e.g., wire harness, cables, leads). Correct if necessary.

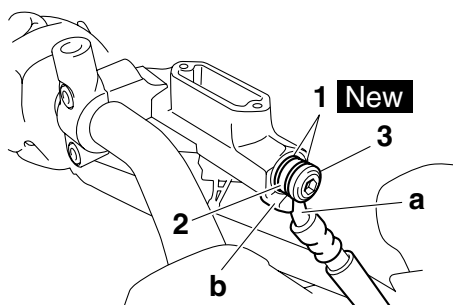

3. Fill:
 - Clutch master cylinder reservoir (with the specified amount of the recommended clutch fluid)

	Recommended fluid DOT 4
--	------------------------------------

EWA13370

WARNING

- Use only the designated clutch fluid. Other clutch fluids may cause the rubber seals to deteriorate, causing leakage and poor clutch performance.
- Refill with the same type of clutch fluid that is already in the system. Mixing clutch fluids may result in a harmful chemical reaction, leading to poor clutch performance.
- When refilling, be careful that water does not enter the clutch fluid reservoir. Water will significantly lower the boiling point of the clutch fluid and could cause vapor lock.

ECA13420

NOTICE

Clutch fluid may damage painted surfaces or plastic parts. Therefore, always clean up any spill clutch fluid immediately.

TIP

In order to ensure a correct reading of the clutch fluid level, make sure the top of the reservoir is horizontal.

4. Bleed:
 - Clutch system
Refer to “BLEEDING THE HYDRAULIC CLUTCH SYSTEM” on page 3-13.
5. Check:
 - Clutch fluid level
Below the minimum level mark “a” → Add the recommended clutch fluid to the proper level. Refer to “CHECKING THE CLUTCH FLUID LEVEL” on page 3-13.

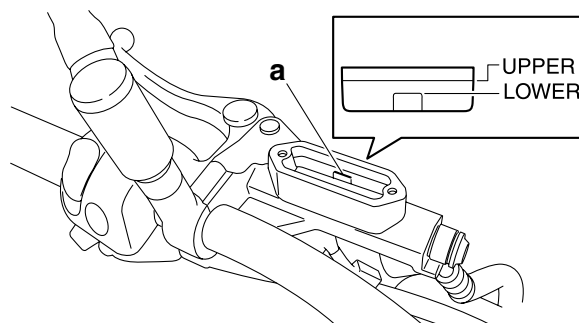

6. Check:
 - Clutch lever operation
Soft or spongy feeling → Bleed the clutch system.
Refer to “BLEEDING THE HYDRAULIC CLUTCH SYSTEM” on page 3-13.

EAS2S31037

REMOVING THE CLUTCH RELEASE CYLINDER

1. Remove:
 - Clutch hose union bolt “1”
 - Clutch hose gasket “2”
 - Clutch hose “3”

TIP

Put the end of the clutch hose into a container and pump out the clutch fluid carefully.

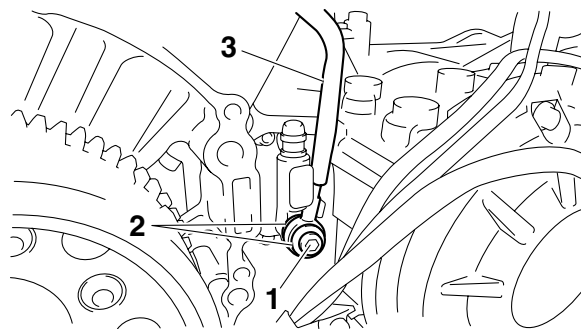

EAS25330

CHECKING THE CLUTCH RELEASE CYLINDER

Recommended clutch component replacement schedule	
Piston seals	Every two years
Clutch hose	Every four years
Clutch fluid	Every two years and whenever the clutch is disassembled

1. Check:
 - Clutch release cylinder body
Cracks/damage → Replace the clutch release cylinder.
2. Check:
 - Clutch release cylinder
 - Clutch release cylinder piston
Rust/scratches/wear → Replace the clutch release cylinder and clutch release cylinder piston as a set.

EAS25340

ASSEMBLING THE CLUTCH RELEASE CYLINDER

EWA2S31011

WARNING

- Before installation, all internal clutch components must be cleaned and lubricated with clean or new clutch fluid.
- Never use solvents on internal clutch components as they will cause the piston seal to swell and distort.
- Whenever a clutch release cylinder is disassembled, replace the piston seal.



**Recommended fluid
DOT 4**

EAS25350

INSTALLING THE CLUTCH RELEASE CYLINDER

1. Install:
 - Clutch release cylinder "1"
 - Clutch release cylinder plate "2"
 - Dowel pins "3"

TIP

Push the plate onto the clutch release cylinder piston, and then turn the plate so that the clasps "a" hooks onto the clutch release cylinder. Then install the dowel pins.

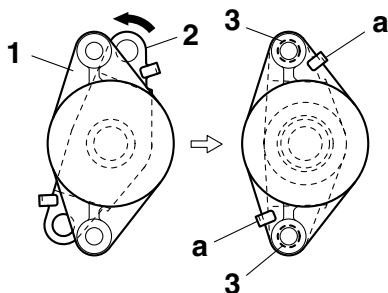

2. Install:
 - Clutch hose gasket "1" **New**
 - Clutch hose "2"

- Clutch hose union bolt "3"



**Clutch hose union bolt
30 Nm (3.0 m·kgf, 22 ft·lbf)**

ECA2S31042

NOTICE

When installing the clutch hose onto the clutch release cylinder, make sure the pipe "a" touches the projection "b" on the clutch release cylinder body.

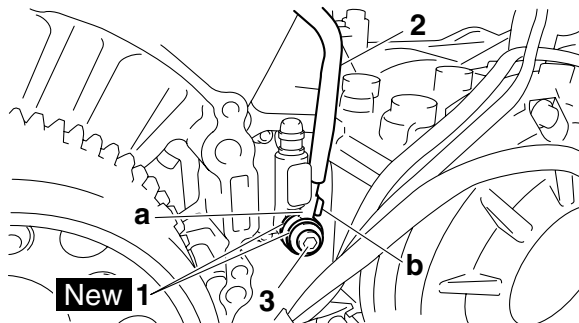

3. Fill:
 - Clutch master cylinder reservoir
(with the specified amount of the recommended clutch fluid)



**Recommended fluid
DOT 4**

EWA13370

WARNING

- Use only the designated clutch fluid. Other clutch fluids may cause the rubber seals to deteriorate, causing leakage and poor clutch performance.
- Refill with the same type of clutch fluid that is already in the system. Mixing clutch fluids may result in a harmful chemical reaction, leading to poor clutch performance.
- When refilling, be careful that water does not enter the clutch fluid reservoir. Water will significantly lower the boiling point of the clutch fluid and could cause vapor lock.

ECA13420

NOTICE

Clutch fluid may damage painted surfaces or plastic parts. Therefore, always clean up any spilt clutch fluid immediately.

TIP

In order to ensure a correct reading of the clutch fluid level, make sure that the top of the reservoir is horizontal.

4. Bleed:

- Clutch system

Refer to “BLEEDING THE HYDRAULIC CLUTCH SYSTEM” on page 3-13.

5. Check:

- Clutch fluid level

Below the minimum level mark “a” → Add the recommended clutch fluid to the proper level.
Refer to “CHECKING THE CLUTCH FLUID LEVEL” on page 3-13.

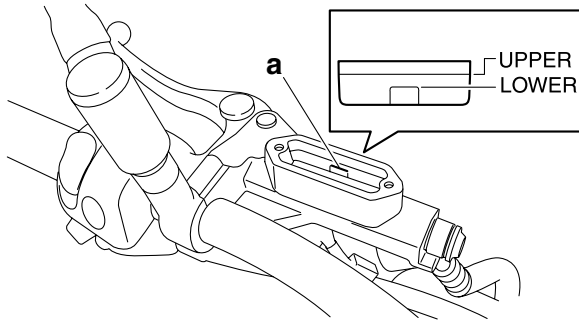

6. Check:

- Clutch lever operation

Soft or spongy feeling → Bleed the clutch system.

Refer to “BLEEDING THE HYDRAULIC CLUTCH SYSTEM” on page 3-13.

EAS25410

SHIFT SHAFT

Removing the shift arm and shift shaft

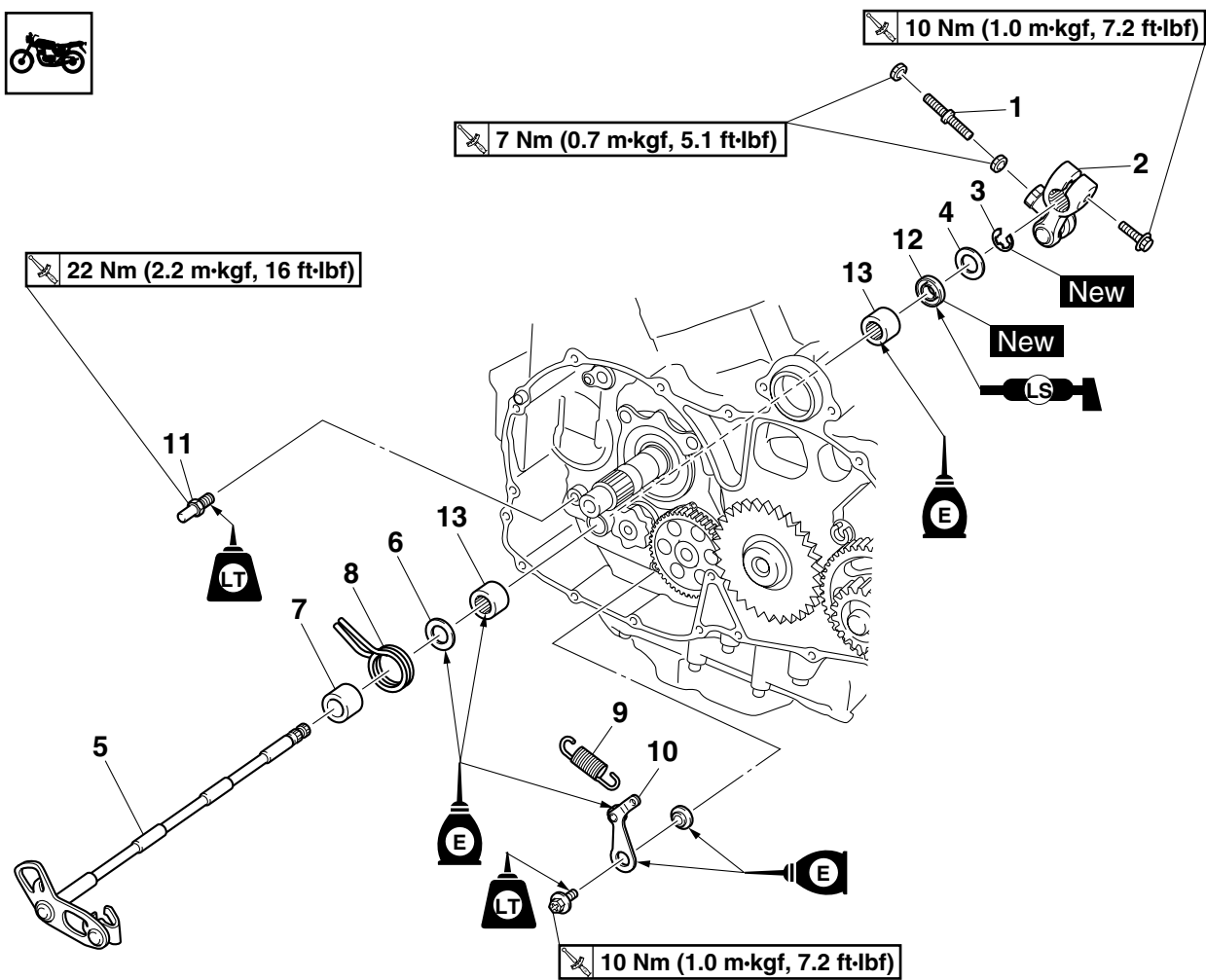

Order	Job/Parts to remove	Q'ty	Remarks
	Clutch housing		Refer to "CLUTCH" on page 5-48.
	Crankcase cover		Refer to "WATER PUMP" on page 6-11.
1	Shift rod	1	TIP The shift rod locknut (shift pedal side) has left-hand threads.
2	Shift arm	1	
3	Circlip	1	
4	Washer	1	
5	Shift shaft	1	
6	Washer	1	
7	Spacer	1	
8	Shift shaft spring	1	
9	Stopper lever spring	1	
10	Stopper lever	1	
11	Shift shaft spring stopper	1	
12	Oil seal	1	

SHIFT SHAFT

Removing the shift arm and shift shaft

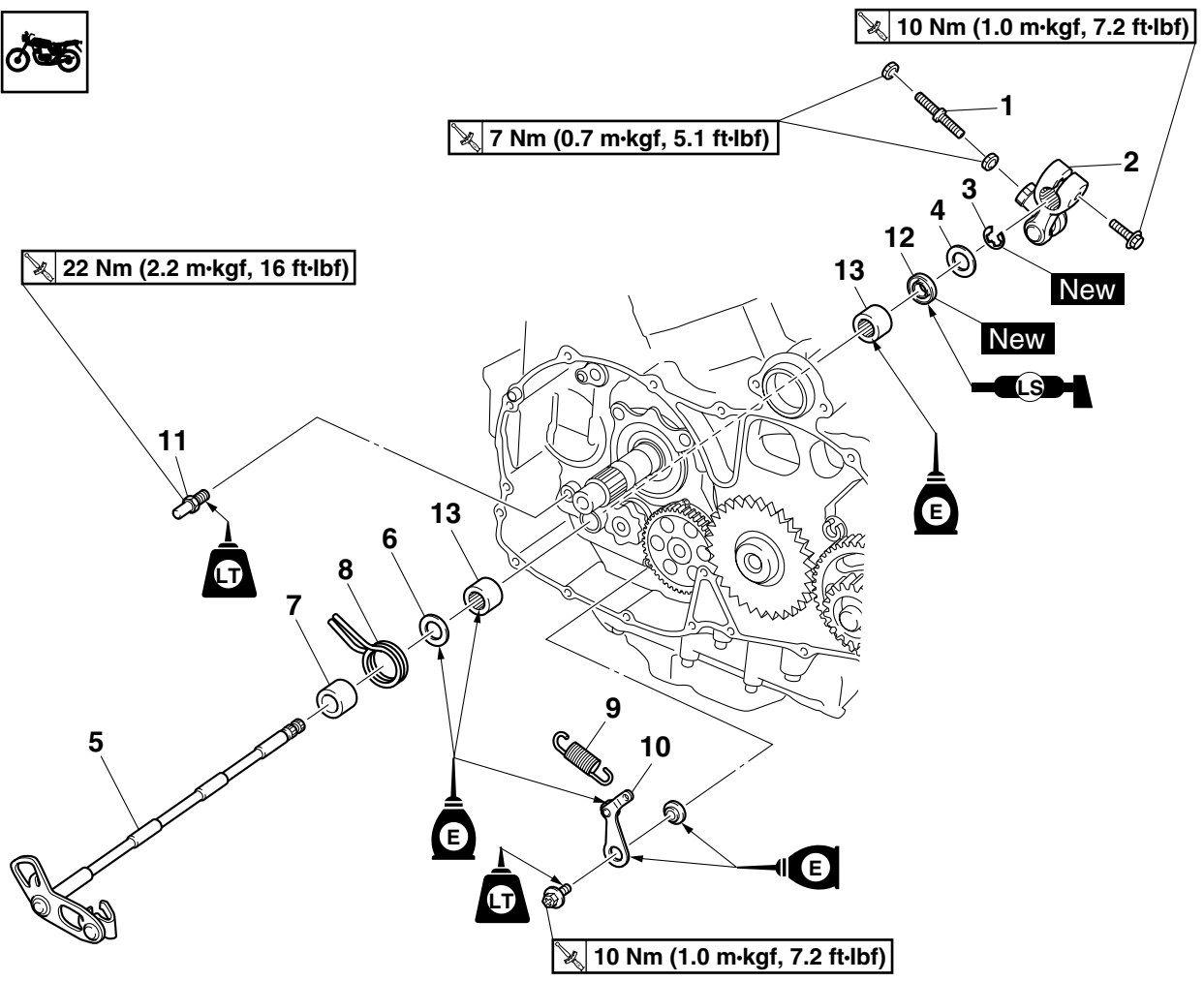

Order	Job/Parts to remove	Q'ty	Remarks
13	Bearing	2	
			For installation, reverse the removal procedure.

EAS25420

CHECKING THE SHIFT SHAFT

1. Check:

- Shift shaft
- Shift shaft spring
Damage/wear → Replace.

EAS25430

CHECKING THE STOPPER LEVER

1. Check:

- Stopper lever
Bends/damage → Replace.
Roller turns roughly → Replace the stopper lever.
- Stopper lever spring
Damage/wear → Replace.

EAS25450

INSTALLING THE SHIFT SHAFT

1. Install:

- Oil seal "1"
(to the lower crankcase)



Installed depth "a"
0.6–1.1 mm (0.024–0.043 in)

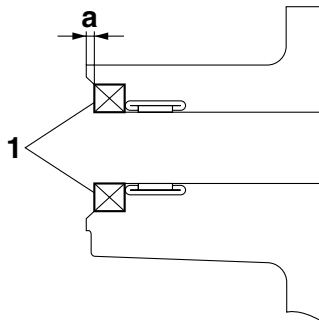

2. Install:

- Stopper lever "1"
- Stopper lever spring "2"

TIP

- Hook the ends of the stopper lever spring onto the stopper lever and the crankcase boss "3".
- Mesh the stopper lever with the shift drum segment assembly.

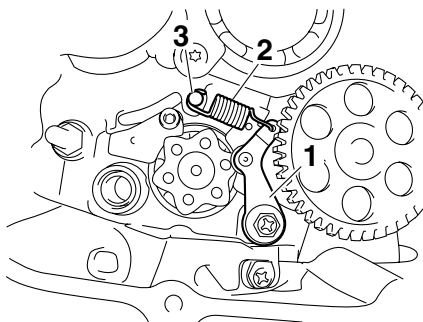

3. Install:

- Shift shaft "1"

TIP

Hook the end of the shift shaft spring onto the shift shaft spring stopper "2".

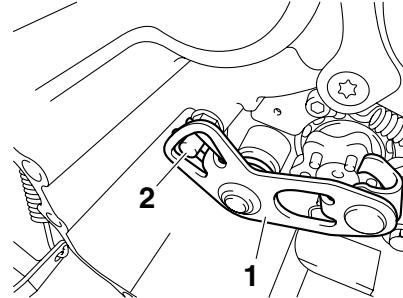

4. Install:

- Shift arm "1"

TIP

Align the punch mark "a" in the shift shaft with the slot in the shift arm.

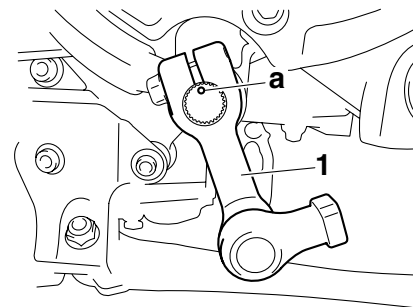

5. Adjust:

- Shift rod length
Refer to "ADJUSTING THE SHIFT PEDAL" on page 3-25.

EAS24921

OIL PUMP

Removing the oil pan and oil pump assembly

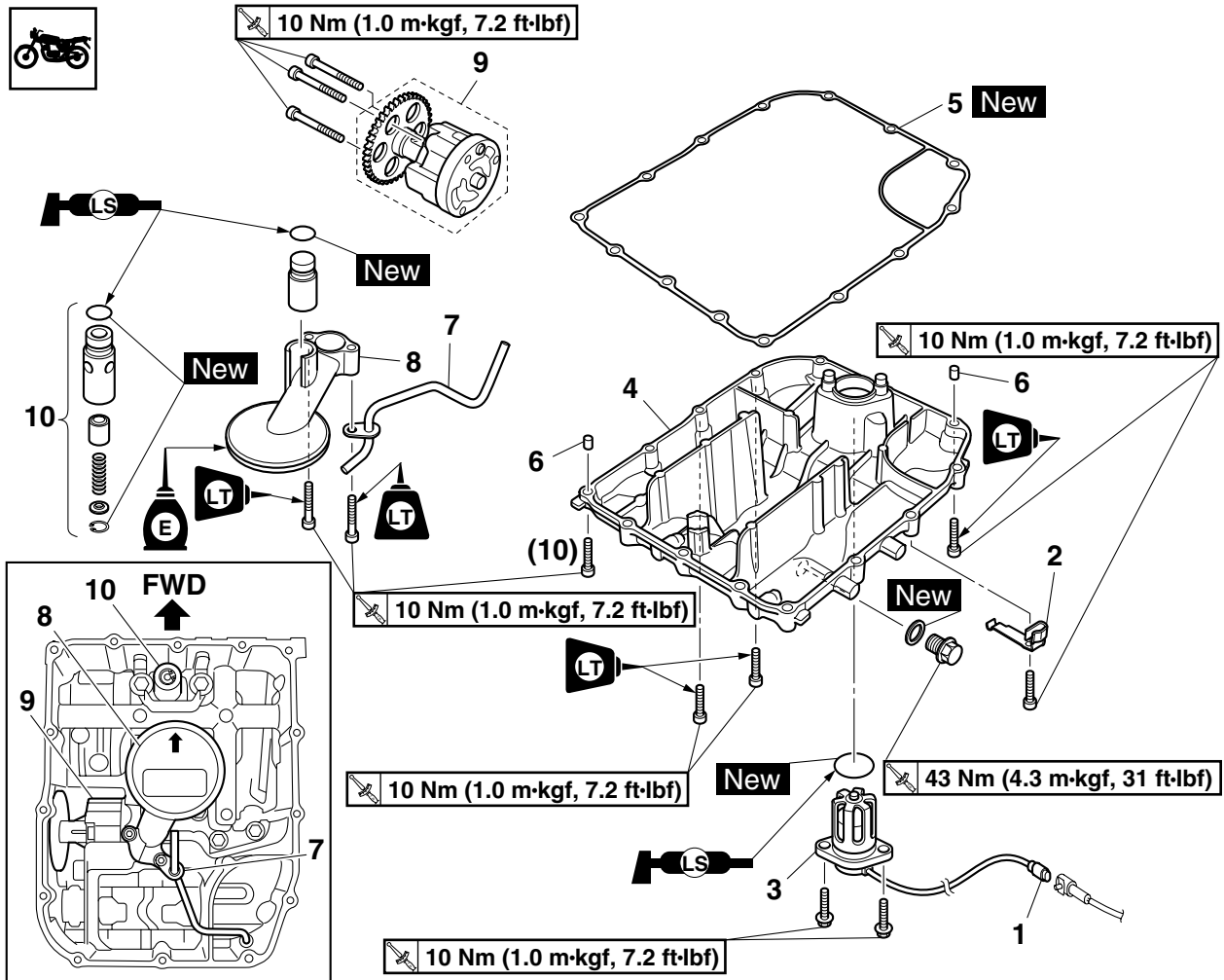

Order	Job/Parts to remove	Q'ty	Remarks
	Engine oil		Drain. Refer to "CHANGING THE ENGINE OIL" on page 3-11.
	Front exhaust pipes		Refer to "ENGINE REMOVAL" on page 5-1.
	Sidestand		Refer to "ENGINE REMOVAL" on page 5-1.
	Clutch housing		Refer to "CLUTCH" on page 5-48.
1	Oil level switch coupler	1	Disconnect.
2	Oil level switch lead holder	1	
3	Oil level switch	1	
4	Oil pan	1	
5	Oil pan gasket	1	
6	Dowel pin	2	
7	Oil pipe 2	1	
8	Oil strainer	1	
9	Oil pump	1	

Removing the oil pan and oil pump assembly

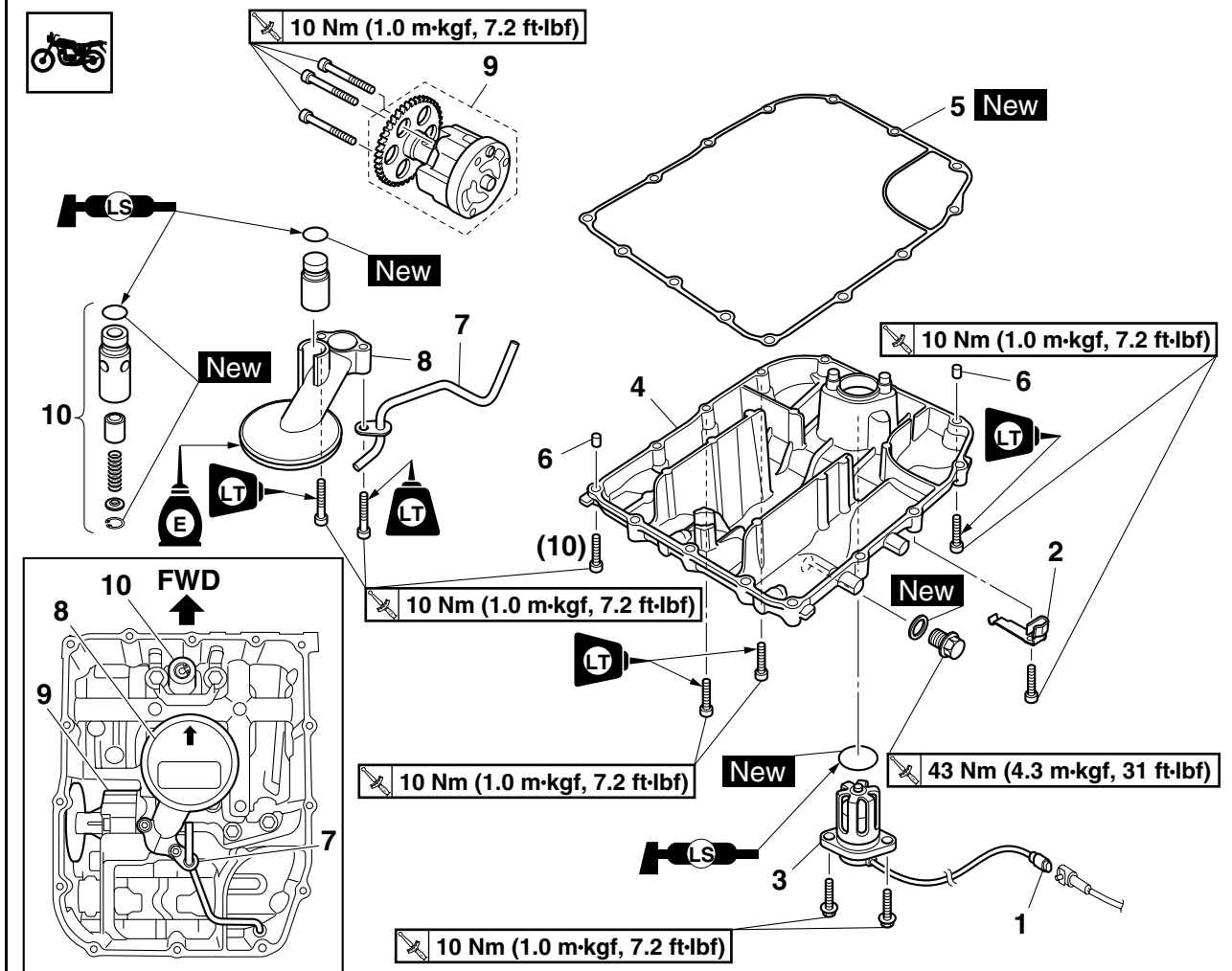

Order	Job/Parts to remove	Q'ty	Remarks
10	Relief valve assembly	1	
			For installation, reverse the removal procedure.

Disassembling the oil pump

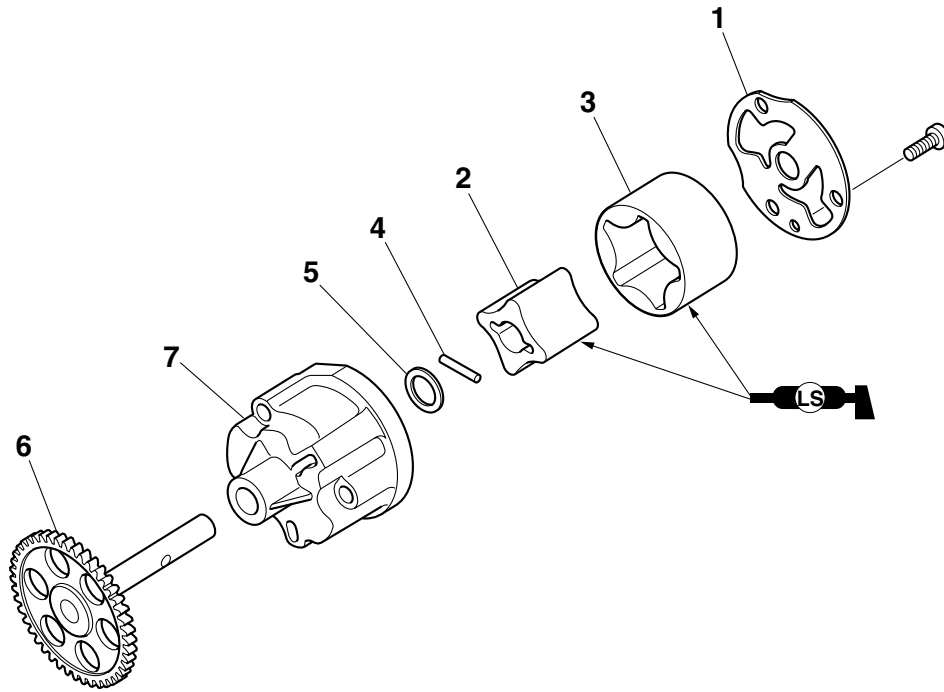

Order	Job/Parts to remove	Q'ty	Remarks
1	Oil pump housing cover	1	
2	Oil pump inner rotor	1	
3	Oil pump outer rotor	1	
4	Pin	1	
5	Washer	1	
6	Oil pump driven gear	1	
7	Oil pump housing	1	
			For assembly, reverse the disassembly procedure.

EAS24930

REMOVING THE OIL PAN

1. Remove:

- Oil level switch lead holder
- Oil pan
- Oil pan gasket

TIP

Loosen each bolt 1/4 of a turn at a time, in stages and in a crisscross pattern. After all of the bolts are fully loosened, remove them.

EAS24960

CHECKING THE OIL PUMP

1. Check:

- Oil pump driven gear
 - Oil pump housing
 - Oil pump housing cover
- Cracks/damage/wear → Replace the defective part(s).

2. Measure:

- Inner-rotor-to-outer-rotor-tip clearance "a"
 - Outer-rotor-to-oil-pump-housing clearance "b"
 - Oil-pump-housing-to-inner-rotor-and-outer-rotor clearance "c"
- Out of specification → Replace the oil pump.

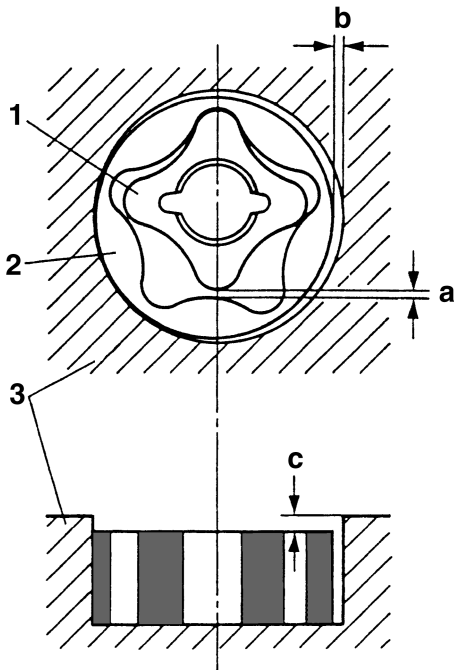

1. Inner rotor
2. Outer rotor
3. Oil pump housing



Inner-rotor-to-outer-rotor-tip clearance

Less than 0.120 mm (0.0047 in)

Limit

0.20 mm (0.0079 in)

Outer-rotor-to-oil-pump-housing clearance

0.090–0.190 mm (0.0035–0.0075 in)

Limit

0.26 mm (0.0102 in)

Oil-pump-housing-to-inner-and-outer-rotor clearance

0.06–0.11 mm (0.0024–0.0043 in)

Limit

0.18 mm (0.0071 in)

3. Check:

- Oil pump operation
- Rough movement → Repeat steps (1) and (2) or replace the defective part(s).

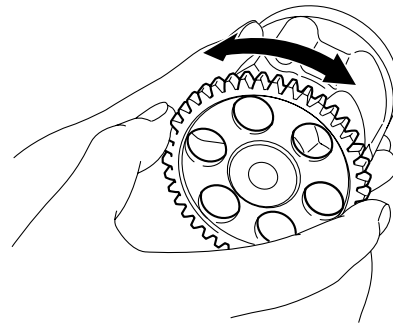

EAS24970

CHECKING THE RELIEF VALVE

1. Check:

- Relief valve body "1"
- Relief valve "2"
- Spring "3"
- O-ring "4"

Damage/wear → Replace the defective part(s).

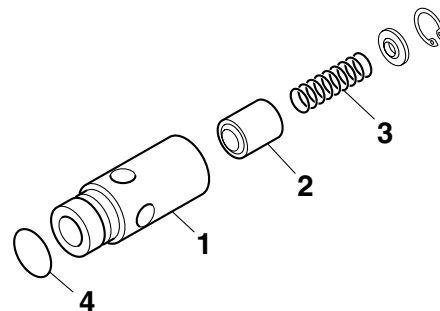

EAS2S31038

CHECKING THE OIL PIPE 2

- Check:
 - Oil pipe 2
 - Damage → Replace.
 - Obstruction → Wash and blow out with compressed air.

EAS24990

CHECKING THE OIL STRAINER

- Check:
 - Oil strainer
 - Damage → Replace.
 - Contaminants → Clean with solvent.

EAS25010

ASSEMBLING THE OIL PUMP

- Lubricate:
 - Inner rotor
 - Outer rotor
 - Oil pump shaft
(with the recommended lubricant)



- Install:
 - Oil pump driven gear
 - Oil pump housing "1"
 - Washer "2"
 - Pin "3"
 - Oil pump inner rotor "4"
 - Oil pump outer rotor

TIP

When installing the inner rotor, align the pin "3" in the oil pump shaft with the groove "a" in the inner rotor "4".

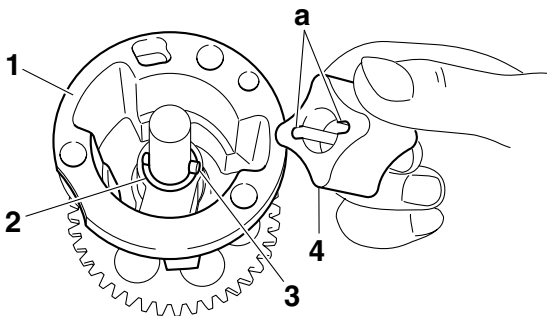

- Check:
 - Oil pump operation
Refer to "CHECKING THE OIL PUMP" on page 5-71.

EAS25030

INSTALLING THE OIL PUMP

- Install:
 - Oil pump "1"



TIP

Align the arrow mark "a" on the oil pump with the arrow mark "b" on the crankcase.

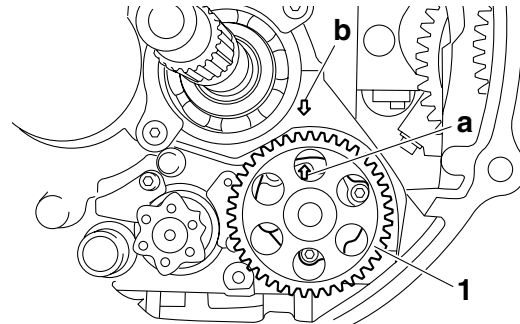

EAS25050

INSTALLING THE OIL PAN

- Install:
 - Oil pan gasket **New**
 - Oil pan

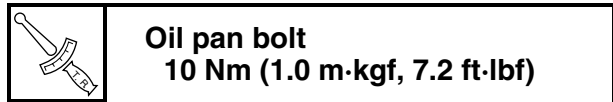

TIP

- Apply locking agent (LOCTITE®) to the bolts installed in the bolt holes marked with arrows "a" on the oil pan.
- Tighten the oil pan bolts in stages and in a crisscross pattern.

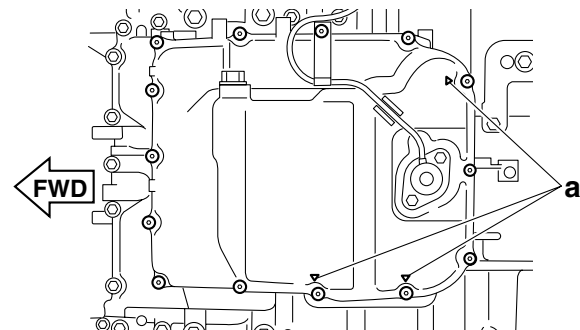

EAS25540

CRANKCASE

Separating the crankcase

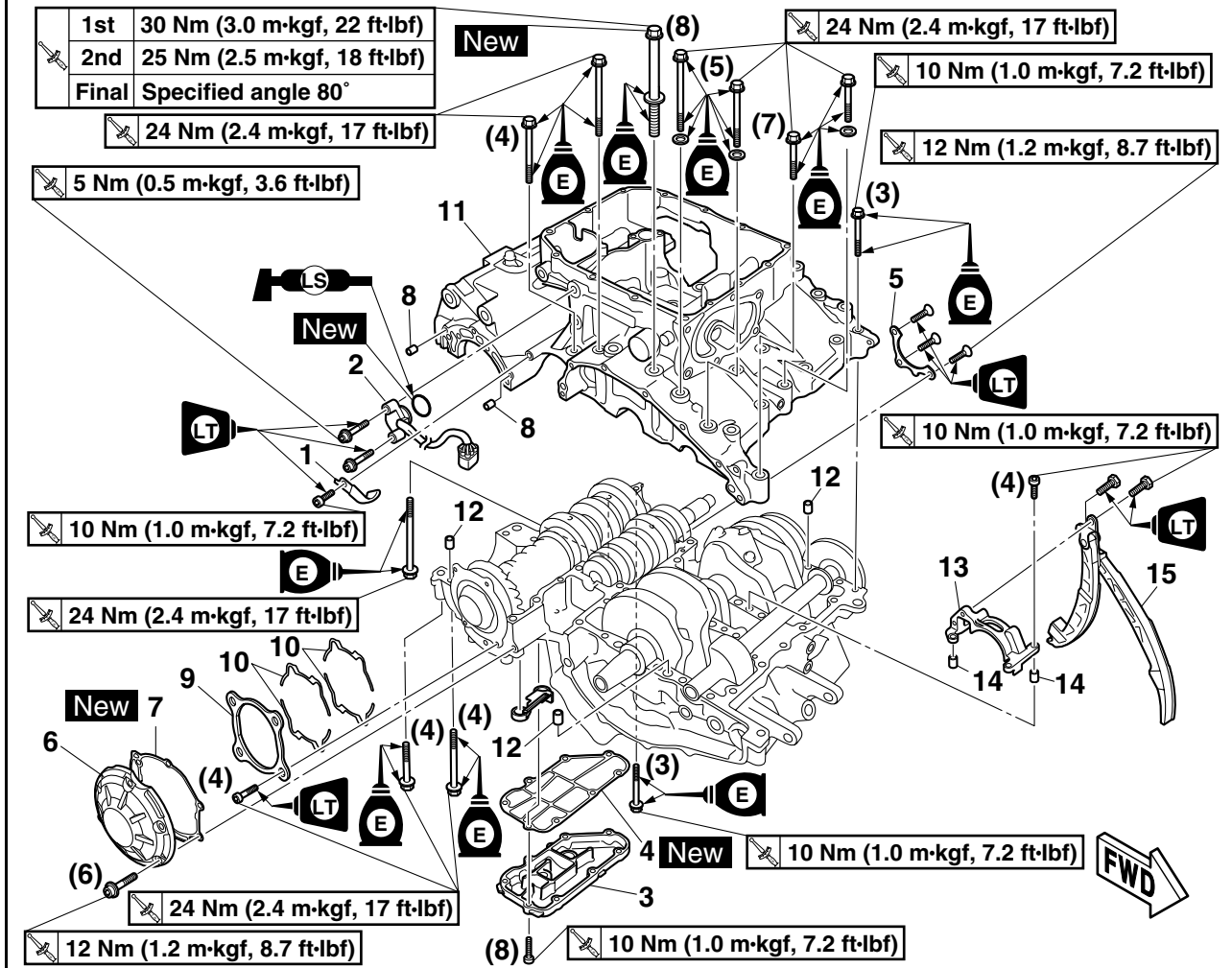

Order	Job/Parts to remove	Q'ty	Remarks
	Engine		Refer to "ENGINE REMOVAL" on page 5-1.
	Cylinder head		Refer to "CYLINDER HEADS" on page 5-26.
	Starter clutch		Refer to "GENERATOR AND STARTER CLUTCH" on page 5-37.
	Clutch housing		Refer to "CLUTCH" on page 5-48.
	Oil pump		Refer to "OIL PUMP" on page 5-68.
	Middle driven pinion gear assembly		Refer to "MIDDLE GEAR" on page 5-105.
	Crankcase cover		Refer to "WATER PUMP" on page 6-11.
1	Gear position switch lead holder	1	
2	Gear position switch	1	
3	Ventilation chamber cover	1	
4	Ventilation chamber cover gasket	1	
5	Main axle bearing retainer	1	
6	Middle gear side cover	1	
7	Middle gear side cover gasket	1	
8	Dowel pin	2	

Separating the crankcase

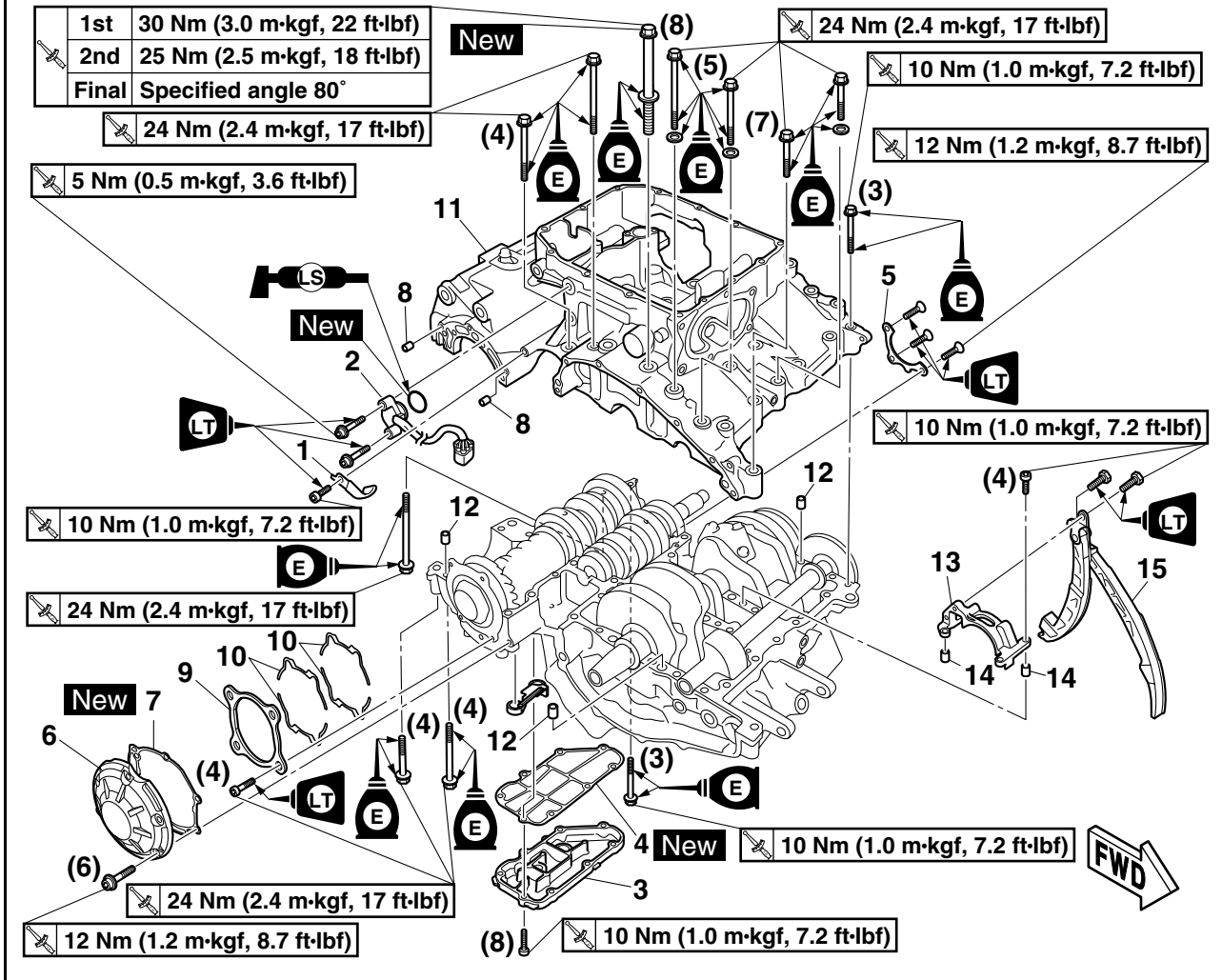

Order	Job/Parts to remove	Q'ty	Remarks
9	Middle drive pinion gear bearing retainer	1	
10	Middle drive pinion gear shim		Refer to "ALIGNING THE MIDDLE GEAR" on page 5-114.
11	Lower crankcase	1	
12	Dowel pin	3	
13	Timing chain guide assembly bracket	1	
14	Dowel pin	2	
15	Timing chain guide assembly	1	
			For installation, reverse the removal procedure.

Removing the plate, oil pipe 3, and damper

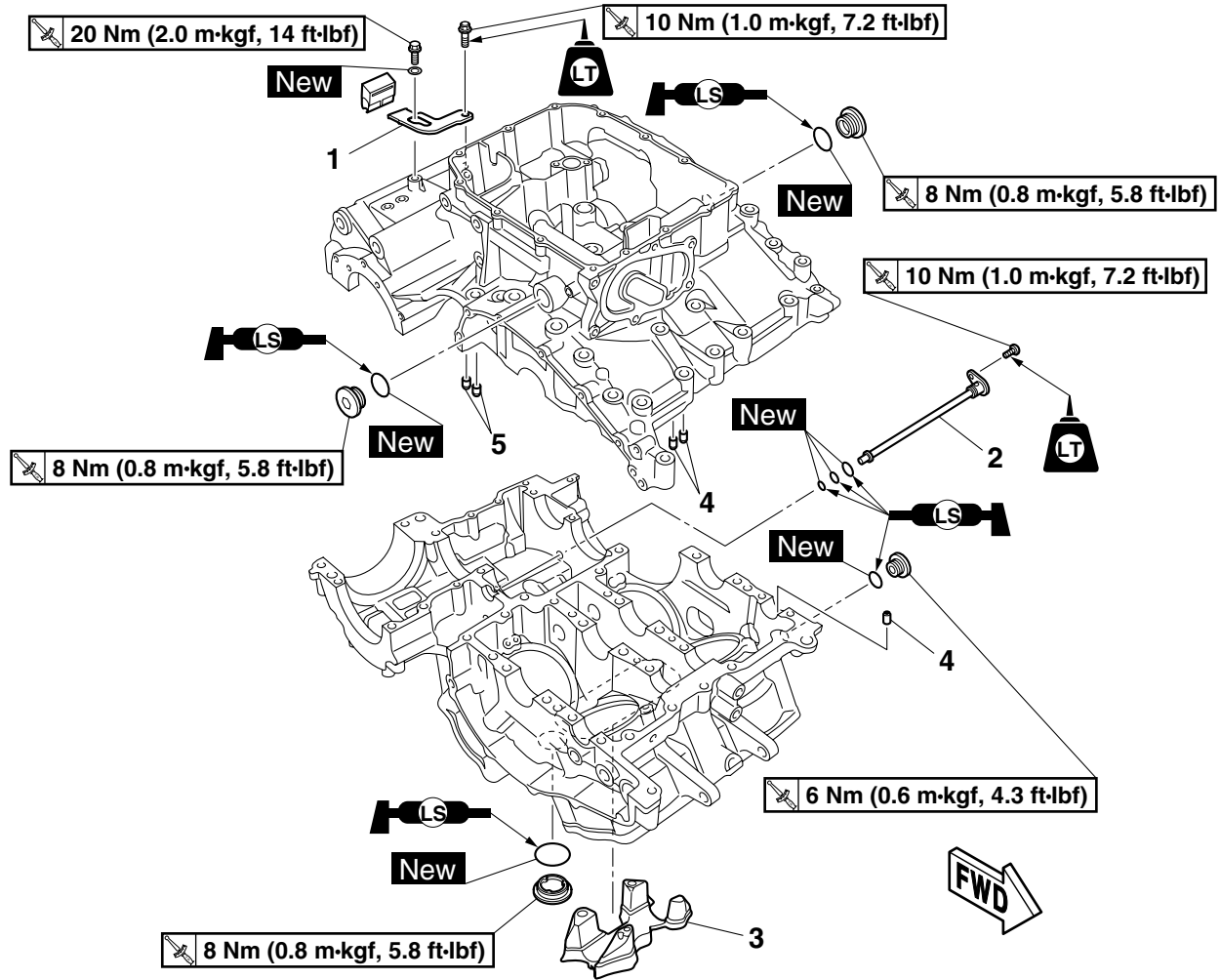

Order	Job/Parts to remove	Q'ty	Remarks
	Connecting rod/Piston		Refer to "CONNECTING RODS AND PISTONS" on page 5-81.
	Crankshaft/Balancer shaft		Refer to "CRANKSHAFT AND BALANCER" on page 5-92.
	Transmission		Refer to "TRANSMISSION" on page 5-98.
1	Plate	1	
2	Oil pipe 3	1	
3	Damper	1	
4	Oil nozzle	3	M6
5	Oil nozzle	2	M8
			For installation, reverse the removal procedure.

EAS25550

DISASSEMBLING THE CRANKCASE

1. Remove:

- Crankcase bolts
- Washers

TIP

- Loosen each bolt 1/4 of a turn at a time, in stages and in a crisscross pattern. After all of the bolts are fully loosened, remove them.
- Loosen the bolts in decreasing numerical order (refer to the numbers in the illustration).
- The numbers embossed on the crankcase indicate the crankcase tightening sequence.

- M10 × 150 mm bolts: “1”–“8”
- M8 × 90 mm bolts: “9”, “10”, “13”–“15”, “21”, “22”, “24”, “26”, “31”, “32”, “35”, “38”
- M8 × 110 mm bolts: “11”, “12”, “39”
- M8 × 65 mm bolts: “16”–“20”, “23”, “25”, “27”, “33”, “34”, “36”, “37”
- M6 × 65 mm bolts: “28”–“30”, “40”–“42”

A

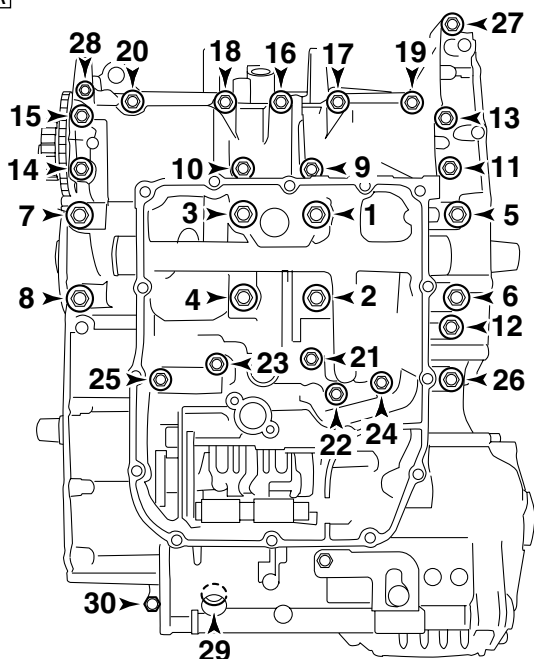

B

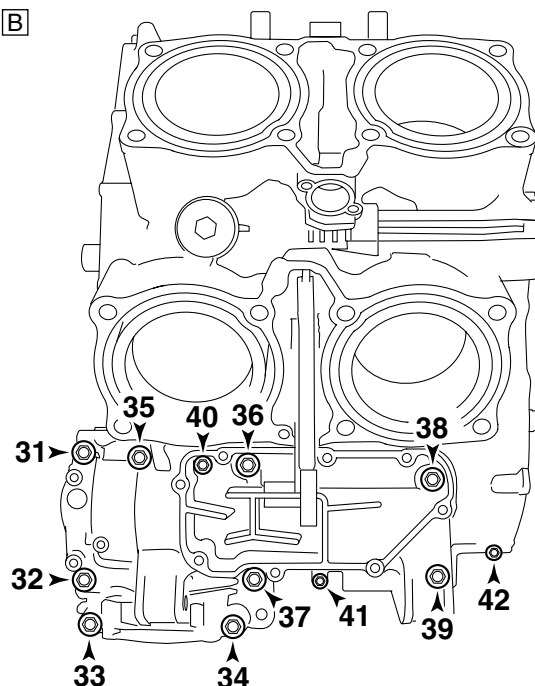

- A. Lower crankcase
B. Upper crankcase

2. Remove:

- Lower crankcase

ECA13900

NOTICE

Tap on one side of the crankcase with a soft-face hammer. Tap only on reinforced portions of the crankcase, not on the crankcase mating surfaces. Work slowly and carefully and make sure the crankcase halves separate evenly.

EAS25580

CHECKING THE CRANKCASE

1. Thoroughly wash the crankcase halves in a mild solvent.
2. Thoroughly clean all the gasket surfaces and crankcase mating surfaces.
3. Check:
 - Crankcase
Cracks/damage → Replace.
 - Oil delivery passages
Obstruction → Blow out with compressed air.

EAS2S31039

CHECKING THE OIL PIPE 3

1. Check:
 - Oil pipe 3
Damage → Replace.
Obstruction → Wash and blow out with compressed air.

EAS2S31040

CHECKING THE TIMING CHAIN GUIDE ASSEMBLY

1. Check:
 - Timing chain guide assembly
Damage/wear → Replace.

EAS2S31096

CHECKING THE OIL NOZZLES

The following procedure applies to all of the oil nozzles.

1. Check:
 - Oil nozzle
Damage/wear → Replace the oil nozzle.
 - Oil passage
Obstruction → Blow out with compressed air.

EAS25680

ASSEMBLING THE CRANKCASE

1. Lubricate:
 - Crankshaft journal bearings
(with the recommended lubricant)
 - Balancer shaft journal bearings
(with the recommended lubricant)

	Recommended lubricant Engine oil
---	---

2. Apply:
 - Sealant
(onto the crankcase mating surfaces)

	Yamaha bond No. 1215 90890-85505 (Three bond No.1215®)
---	---

ECA2S31066

NOTICE

Do not allow any sealant to come into contact with the oil gallery, crankshaft journal bearings, or balancer shaft journal bearings. Do not apply sealant to within 2–3 mm (0.08–0.12 in) of the crankshaft journal bearings.

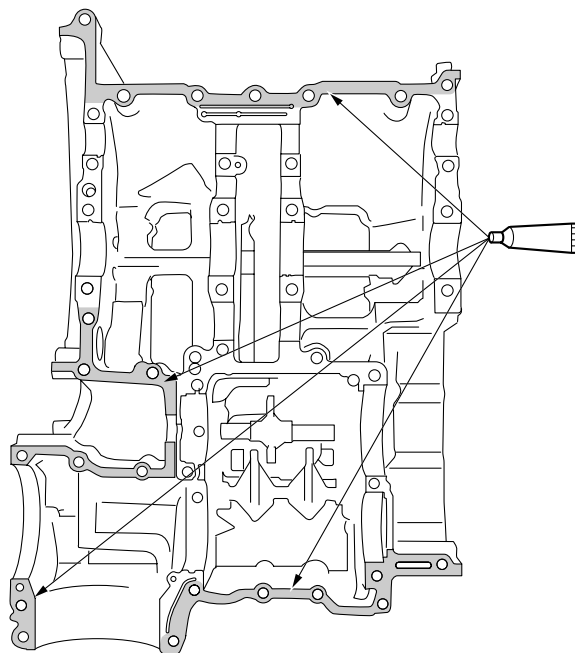

3. Install:
 - Dowel pins
4. Set the shift drum assembly and transmission gears in the neutral position.
5. Install:
 - Lower crankcase “1”
(onto the upper crankcase “2”)

ECA13980

NOTICE

Before tightening the crankcase bolts, make sure the transmission gears shift correctly when the shift drum assembly is turned by hand.

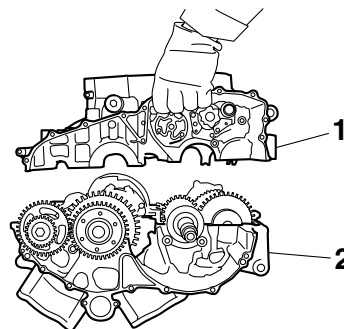

6. Install:
 - Washer “1”
 - Crankcase bolts

EWA2S31012

WARNING

Replace the bolts “1”–“8” with new ones.

CRANKCASE

EWA2S31013

WARNING

If the bolt is tightened more than the specified angle, do not loosen the bolt and then re-tighten it. Instead, replace the bolt with a new one and perform the procedure again.

ECA2S31043

NOTICE

- Do not use a torque wrench to tighten the bolt to the specified angle.
- Tighten the bolt until it is at the specified angle.

TIP

On a hexagonal bolt, note that the angle from one corner to another is 60°.

- d. Repeat steps (a) and (b) for each of the crankcase bolts "2"–"8" in order.

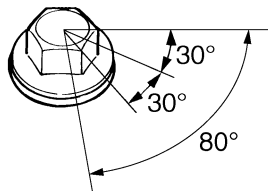
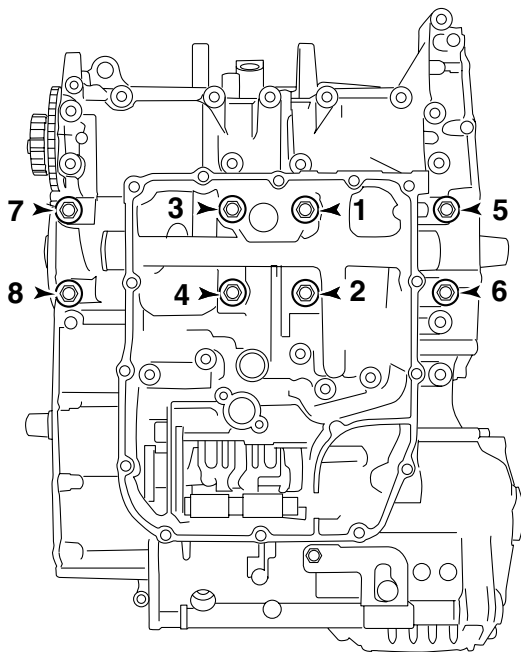

Crankcase bolt "9"–"27", "31"–"39"

24 Nm (2.4 m·kgf, 17 ft·lbf)

Crankcase bolt "28"–"30", "40"–"42"

10 Nm (1.0 m·kgf, 7.2 ft·lbf)

TIP

Tighten the crankcase bolts in the proper tightening sequence as shown.

A

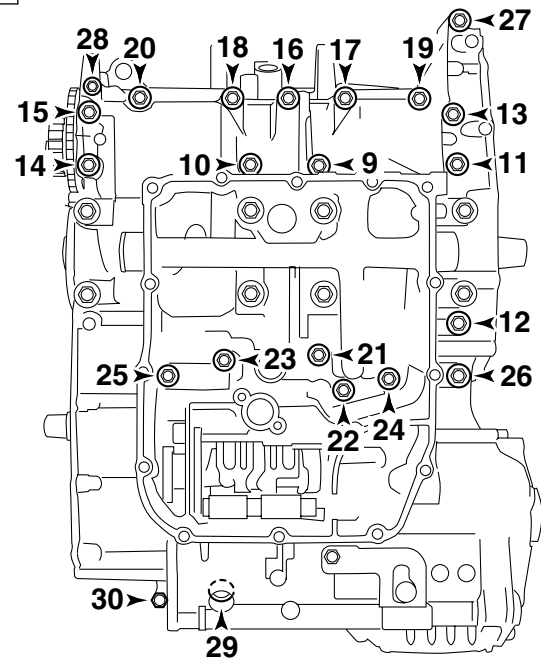

8. Tighten:

- Crankcase bolts "9"–"42"

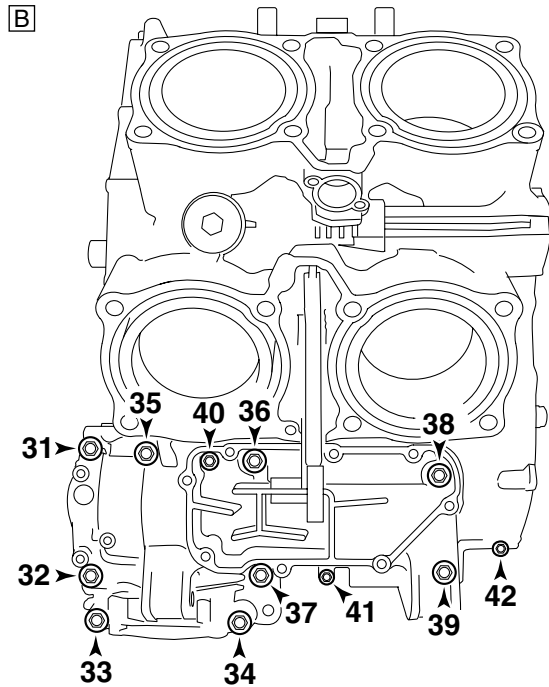

- A. Lower crankcase
- B. Upper crankcase

9. Install:

- Middle drive pinion gear bearing retainer "1"



Middle drive pinion gear bearing retainer bolt
24 Nm (2.4 m·kgf, 17 ft·lbf)
LOCTITE®

TIP

Install the middle drive pinion gear bearing retainer with its arrow mark "a" facing up.

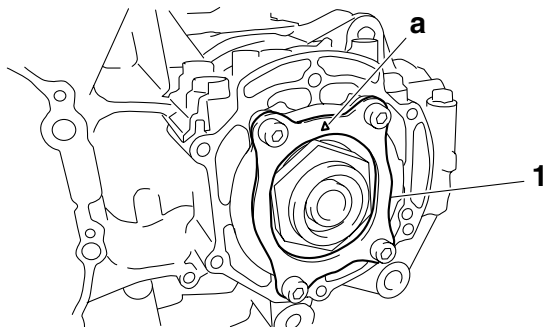

10. Install:

- Main axle bearing retainer "1"



Main axle bearing retainer bolt
12 Nm (1.2 m·kgf, 8.7 ft·lbf)
LOCTITE®

TIP

Install the main axle bearing retainer with its "OUT" mark "a" facing outward.

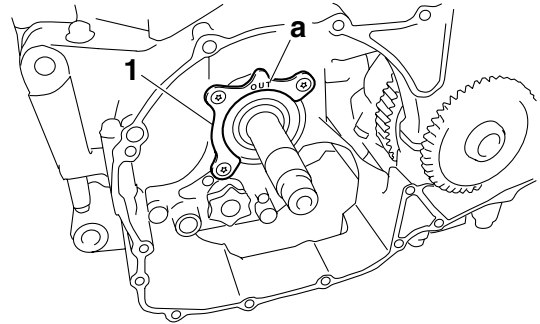

CONNECTING RODS AND PISTONS

EAS26030

REMOVING THE CONNECTING RODS AND PISTONS

The following procedure applies to all of the connecting rods and pistons.

1. Remove:

- Connecting rod cap "1"

TIP

Identify the position of each connecting rod cap so that it can be reinstalled in its original place.

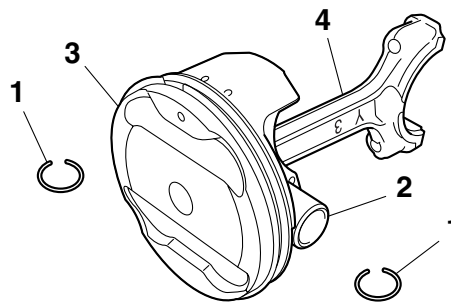
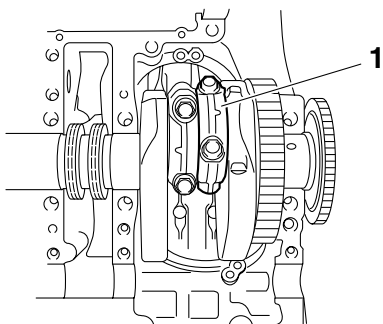

2. Remove:

- Big end bearings
(from the connecting rods and connecting rod caps)

TIP

Identify the position of each big end bearing so that it can be reinstalled in its original place.

3. Remove:

- Piston pin clips "1"
- Piston pin "2"
- Piston "3"
- Connecting rod "4"

ECA13810

NOTICE

Do not use a hammer to drive the piston pin out.

TIP

- For reference during installation, put identification marks on the piston crown.
- Before removing the piston pin, deburr the piston pin clip groove and the piston pin bore area. If both areas are deburred and the piston pin is still difficult to remove, remove it with the piston pin puller set "5".



**Piston pin puller set
90890-01304
Piston pin puller
YU-01304**

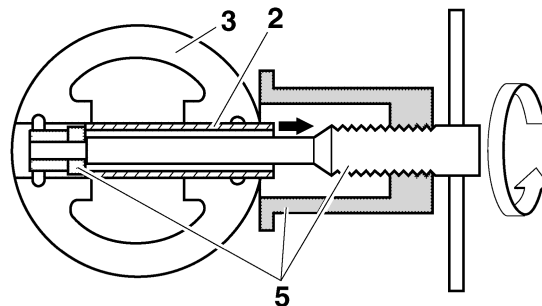

4. Remove:

- Top ring
- 2nd ring
- Oil ring

TIP

When removing a piston ring, open the end gap with your fingers and lift the other side of the ring over the piston crown.

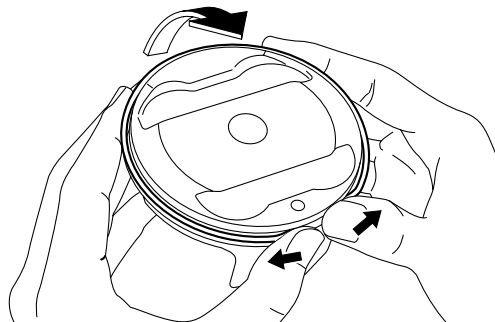

EAS2S31093

CHECKING THE OIL NOZZLES

The following procedure applies to all of the oil nozzles.

1. Check:

- Oil nozzle
Damage/wear → Replace the oil nozzle.
- Oil passage
Obstruction → Blow out with compressed air.

EAS24410

CHECKING THE CYLINDERS AND PISTONS

The following procedure applies to all of the cylinders and pistons.



Piston ring
Top ring
 Ring side clearance
 0.030–0.070 mm (0.0012–
 0.0028 in)
 Limit
 0.120 mm (0.0047 in)
2nd ring
 Ring side clearance
 0.020–0.060 mm (0.0008–
 0.0024 in)
 Limit
 0.120 mm (0.0047 in)

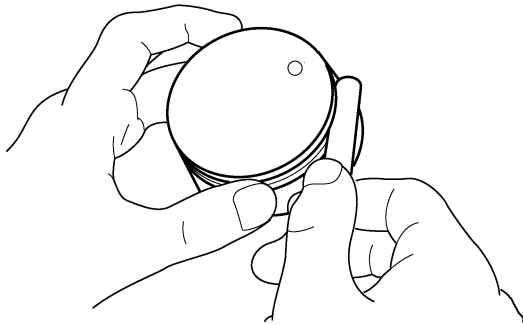

2. Install:
- Piston ring
 (into the cylinder)

TIP

Level the piston ring into the cylinder with the piston crown.

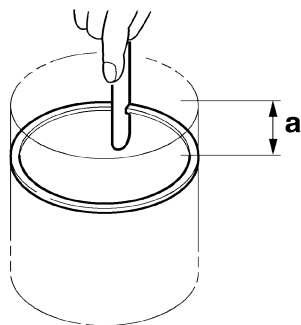

a. 9.8 mm (0.39 in)

3. Measure:
- Piston ring end gap
 Out of specification → Replace the piston ring.

TIP

The oil ring expander spacer's end gap cannot be measured. If the oil ring rail's gap is excessive, replace all three piston rings.



Piston ring
Top ring
 End gap (installed)
 0.20–0.35 mm (0.0079–0.0138
 in)
 Limit
 0.60 mm (0.0236 in)
2nd ring
 End gap (installed)
 0.40–0.55 mm (0.0157–0.0217
 in)
 Limit
 0.80 mm (0.0315 in)
Oil ring
 End gap (installed)
 0.20–0.50 mm (0.0079–0.0197
 in)

EAS24440

CHECKING THE PISTON PINS

The following procedure applies to all of the piston pins.

1. Check:
 - Piston pin
 Blue discoloration/grooves → Replace the piston pin and then check the lubrication system.
2. Measure:
 - Piston pin outside diameter “a”
 Out of specification → Replace the piston pin.



Piston pin outside diameter
 18.991–19.000 mm (0.7477–
 0.7480 in)
 Limit
 18.971 mm (0.7469 in)

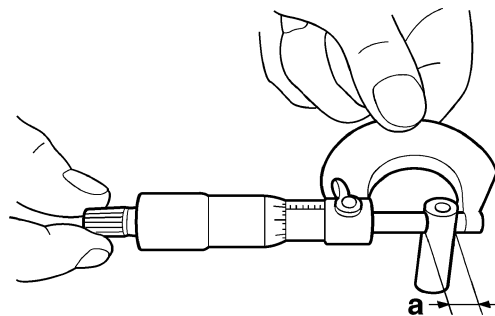

3. Measure:
- Piston pin bore inside diameter “b”
 Out of specification → Replace the piston.

CONNECTING RODS AND PISTONS

ECA2S31044

NOTICE

Tighten the connecting rod bolts using the plastic-region tightening angle method. Always install new bolts.

- f. Clean the connecting rod bolts.
- g. After installing the big end bearing, assemble the connecting rod and connecting rod cap without installing them onto the crankshaft.

TIP

Install by carrying out the following procedures in order to assemble in the most suitable condition.

- h. Tighten the connecting rod bolt while checking that the sections shown "a" and "b" are flush with each other by touching the surface.



Connecting rod bolt
30 Nm (3.0 m·kgf, 22 ft·lbf)

TIP

To install the big end bearing, care should be taken not to install it at an angle and the position should not be out of alignment.

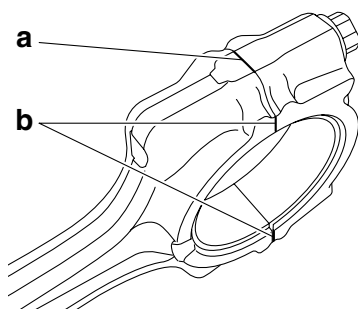

- a. Side machined face
- b. Thrusting faces

- i. Loosen the connecting rod bolt, remove the connecting rod and connecting rod cap and install these parts to the crankshaft with the big end bearing kept in the current condition.

TIP

- Do not move the connecting rod or crankshaft until the clearance measurement has been completed.
- Make sure the "Y" mark "a" on the #1 and #3 connecting rods faces toward the left side of the crankcase.
- Make sure the "Y" mark "a" on the #2 and #4 connecting rods faces toward the right side of the crankcase.

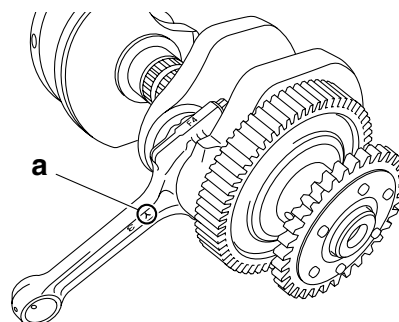

A

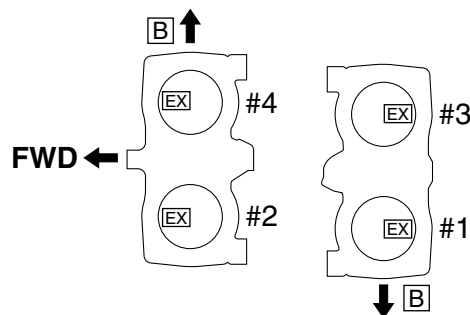

- A. Top view
- B. "Y" mark side

- j. Tighten the connecting rod bolts.



Connecting rod bolt
1st
20 Nm (2.0 m·kgf, 14 ft·lbf)

- k. Put a mark "1" on the corner of the connecting rod bolt "2" and the connecting rod cap "3".

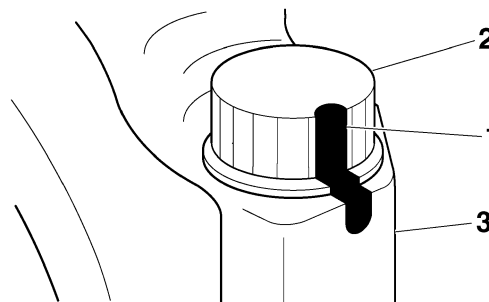

- l. Tighten the bolt further to reach the specified angle.



Connecting rod bolt
Final
Specified angle 130–140°

CONNECTING RODS AND PISTONS

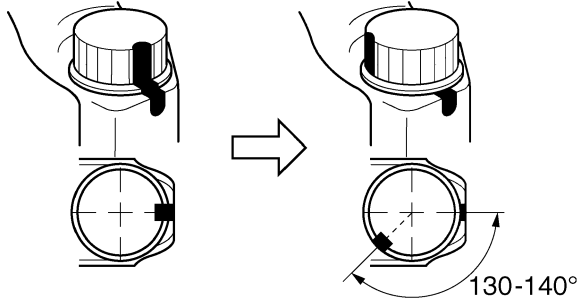

EWA2S31038

WARNING

- When a bolt is tightened more than the specified angle, do not loosen the bolt and then retighten it. Replace the bolt with a new one and perform the procedure again.
- If the connecting rod and cap are not flush with each other, remove the connecting rod bolts and big end bearing and restart from step (e). In this case, make sure to replace the connecting rod bolt.

ECA2S31077

NOTICE

- Do not use a torque wrench to tighten the nut to the specified angle.
- Tighten the bolts until they are within the specified angles.

TIP

After installation, check that the section “a” is flush by running your finger across the surface.

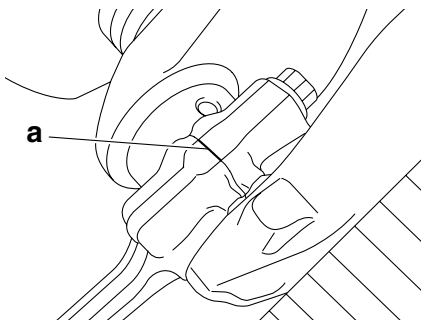

- Remove the connecting rod and big end bearings. Refer to “REMOVING THE CONNECTING RODS AND PISTONS” on page 5-82.
- Measure the compressed Plastigauge® width on the crankshaft pin. If the crankshaft-pin-to-big-end-bearing clearance is out of specification, select replacement big end bearings.

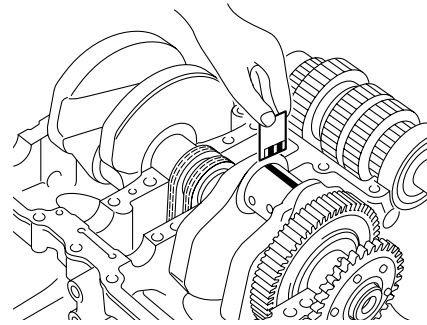

2. Select:

- Big end bearing (P₁–P₂)

TIP

- The numbers “A” stamped into the crankshaft web and the numbers “B” on the connecting rods are used to determine the replacement big end bearing sizes.
- “P₁”–“P₂” refer to the bearings shown in the crankshaft illustration.

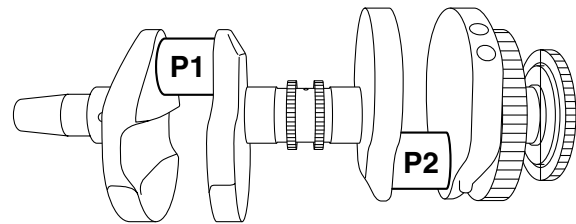

A

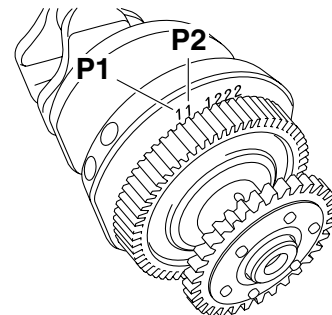

B

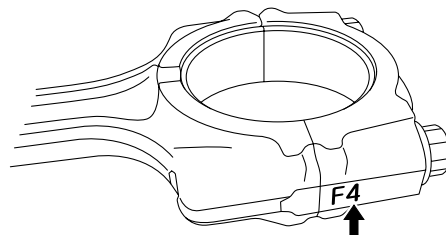

CONNECTING RODS AND PISTONS

For example, if the connecting rod “P₁” and the crankshaft web “P₁” numbers are “4” and “1” respectively, then the bearing size for “P₁” is:

$$P_1 \text{ (connecting rod)} - P_1 \text{ (crankshaft web)} = 4 - 1 = 3 \text{ (brown)}$$



Bearing color code
1.Blue 2.Black 3.Brown 4.Green

EAS26170

INSTALLING THE CONNECTING RODS AND PISTONS

The following procedure applies to all of the connecting rods and pistons.

1. Install:

- Big end bearings
- Connecting rod cap (onto the connecting rod)

TIP

- Be sure to reinstall each big end bearing in its original place.
- Align the projections “a” on the big end bearings with the notches “b” in the connecting rods and connecting rod caps.
- Make sure that the projection “c” on the connecting rod cap faces the same direction as the “Y” mark “d” on the connecting rod.

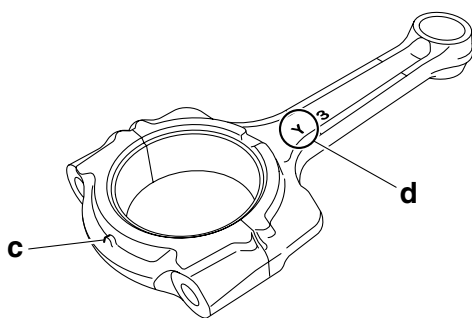
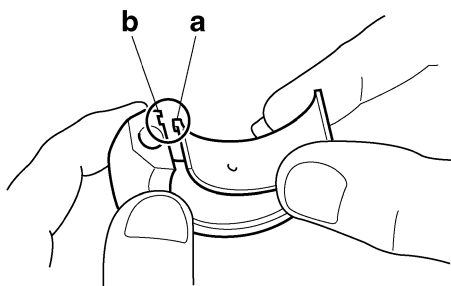

2. Tighten:

- Connecting rod bolts

ECA2S31046

NOTICE

Tighten the connecting rod bolts using the plastic-region tightening angle method. Always install new bolts.

TIP

Install by carrying out the following procedures in order to assemble in the most suitable condition.

- Replace the connecting rod bolts with new ones.
- Clean the connecting rod bolts.
- After installing the big end bearing, assemble the connecting rod and connecting rod cap without installing them onto the crankshaft.
- Tighten the connecting rod bolt while checking that the sections shown “a” and “b” are flush with each other by touching the surface.



Connecting rod bolt
30 Nm (3.0 m·kgf, 22 ft·lbf)

TIP

To install the big end bearing, care should be taken not to install it at an angle and the position should not be out of alignment.

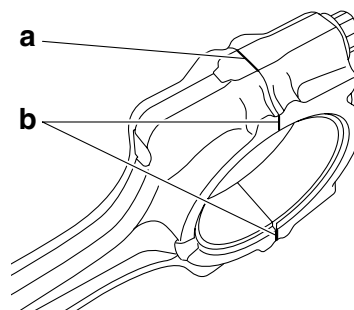

- Side machined face
- Thrusting faces

- Loosen the connecting rod bolt, remove the connecting rod and connecting rod cap and install these parts to the crankshaft with the big end bearing kept in the current condition.

3. Install:

- Lower oil ring rail “1”
- Oil ring expander “2”
- Upper oil ring rail “3”
- 2nd ring “4”
- Top ring “5”

CONNECTING RODS AND PISTONS

TIP

Be sure to install the piston rings so that the manufacturer marks face up.

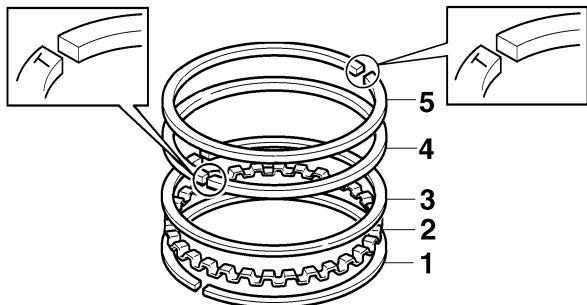

4. Install:

- Piston “1”
(onto its respective connecting rod “2”)
- Piston pin “3”
- Piston pin clips “4” **New**

TIP

- Apply engine oil onto the piston pin.
- Make sure that the “Y” mark “a” on the connecting rod is facing to the right of the piston when the punch mark “b” on the piston is pointing up. Refer to the illustration.
- When installing a piston pin clip, make sure that the clip ends are positioned away from the cutout in the piston as shown in the illustration.
- Reinstall each piston into its original cylinder (numbering order starting from the left: #1 to #4).

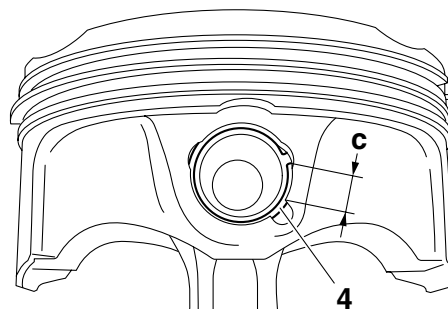
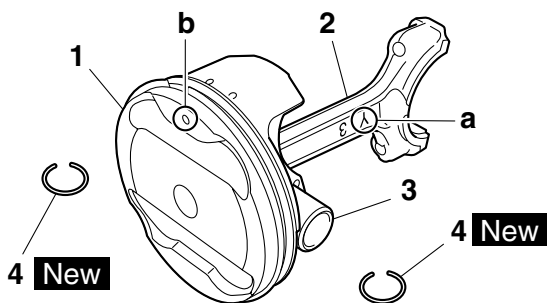

c. More than 3 mm (0.12 in)

5. Lubricate:

- Piston
- Piston rings
- Cylinder
(with the recommended lubricant)



6. Offset:

- Piston ring end gaps

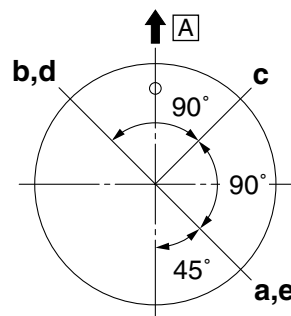

- a. Top ring
- b. Lower oil ring rail
- c. Upper oil ring rail
- d. 2nd ring
- e. Oil ring expander
- A. Exhaust side

7. Lubricate:

- Connecting rod bolt threads
(with the recommended lubricant)

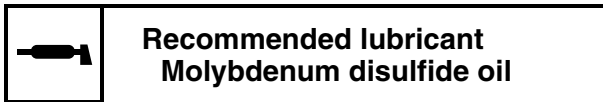

8. Lubricate:

- Crankshaft pins
- Big end bearings
- Connecting rod big end inner surface
(with the recommended lubricant)

CONNECTING RODS AND PISTONS

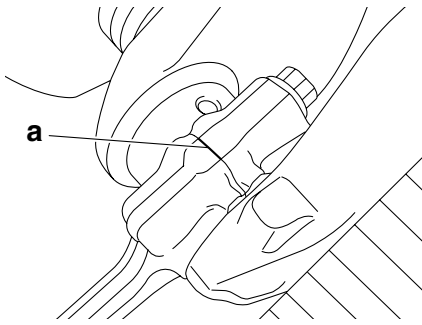

EAS25950

CRANKSHAFT AND BALANCER

Removing the crankshaft and balancer

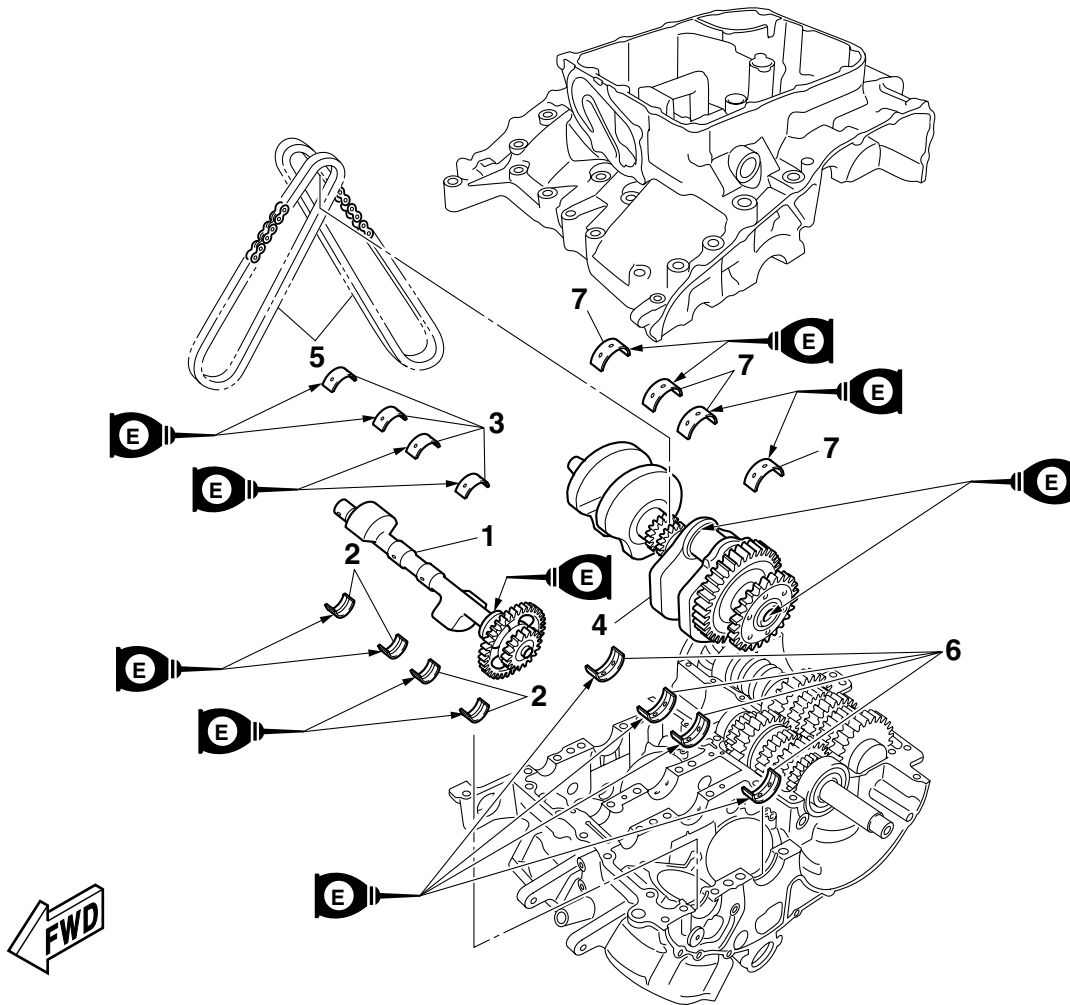

Order	Job/Parts to remove	Q'ty	Remarks
	Crankcase		Separate. Refer to "CRANKCASE" on page 5-73.
	Connecting rod caps		Refer to "CONNECTING RODS AND PISTONS" on page 5-81.
1	Balancer shaft	1	
2	Balancer shaft journal upper bearing	4	
3	Balancer shaft journal lower bearing	4	
4	Crankshaft	1	
5	Timing chain	2	
6	Crankshaft journal upper bearing	4	
7	Crankshaft journal lower bearing	4	
			For installation, reverse the removal procedure.

EAS2S31094

REMOVING THE BALANCER SHAFT JOURNAL BEARINGS

- Remove:
 - Balancer shaft journal upper bearings (from the upper crankcase)
 - Balancer shaft journal lower bearings (from the lower crankcase)

TIP

Identify the position of each balancer shaft journal bearing so that it can be reinstalled in its original place.

EAS26040

REMOVING THE CRANKSHAFT JOURNAL BEARINGS

- Remove:
 - Crankshaft journal upper bearings (from the upper crankcase)
 - Crankshaft journal lower bearings (from the lower crankcase)

TIP

Identify the position of each crankshaft journal bearing so that it can be reinstalled in its original place.

EAS2S31044

CHECKING THE TIMING CHAINS

- Check:
 - Timing chain
Damage/stiffness → Replace the timing chain, camshaft sprocket, and crankshaft as a set.

EAS26070

CHECKING THE CRANKSHAFT

- Measure:
 - Crankshaft runout
Out of specification → Replace the crankshaft.



Runout limit C
0.030 mm (0.0012 in)

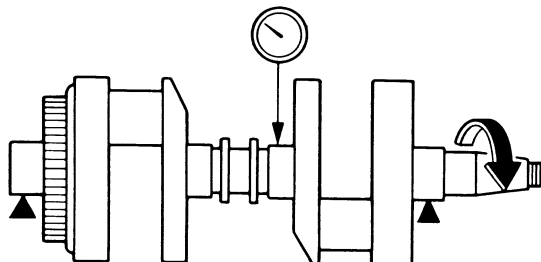

- Check:
 - Crankshaft journal surfaces
 - Crankshaft pin surfaces
 - Bearing surfaces
Scratches/wear → Replace the crankshaft.
- Measure:
 - Crankshaft-journal-to-crankshaft-journal-bearing clearance
Out of specification → Replace the crankshaft journal bearings.



Journal oil clearance
0.032–0.056 mm (0.0013–0.0022 in)

ECA13920

NOTICE

Do not interchange the crankshaft journal bearings. To obtain the correct crankshaft-journal-to-crankshaft-journal-bearing clearance and prevent engine damage, the crankshaft journal bearings must be installed in their original positions.

- Clean the crankshaft journal bearings, crankshaft journals, and bearing portions of the crankcase.
- Place the upper crankcase upside down on a bench.
- Install the crankshaft journal upper bearings “1” and the crankshaft into the upper crankcase.

TIP

Align the projections “a” on the crankshaft journal upper bearings with the notches “b” in the upper crankcase.

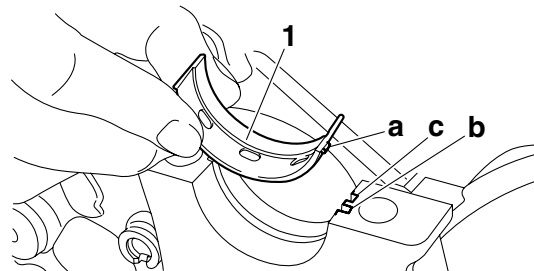

- Oil groove
- Put a piece of Plastigauge® “2” on each crankshaft journal.

TIP

Do not put the Plastigauge® over the oil hole in the crankshaft journal.

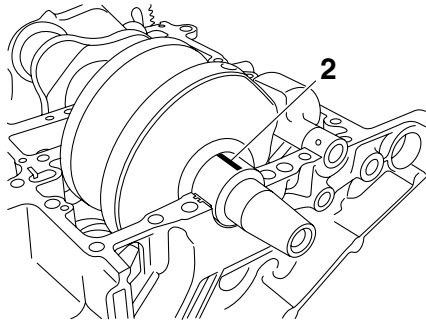

e. Install the crankshaft journal lower bearings “3” into the lower crankcase and assemble the crankcase halves.

TIP

- Align the projections “d” of the crankshaft journal lower bearings with the notches “e” in the lower crankcase.
- Do not move the crankshaft until the clearance measurement has been completed.

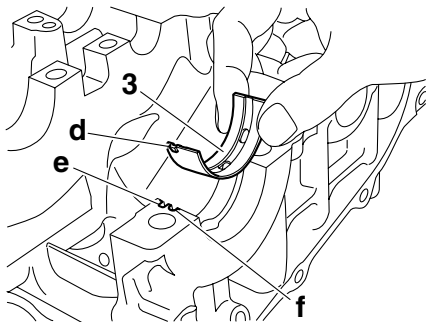

- f. Oil groove
- f. Tighten the bolts to specification in the tightening sequence cast on the crankcase. Refer to “CRANKCASE” on page 5-73.
- g. Remove the lower crankcase and the crankshaft journal lower bearings.
- h. Measure the compressed Plastigauge® width “g” on each crankshaft journal. If the crankshaft-journal-to-crankshaft-journal-bearing clearance is out of specification, select replacement crankshaft journal bearings.

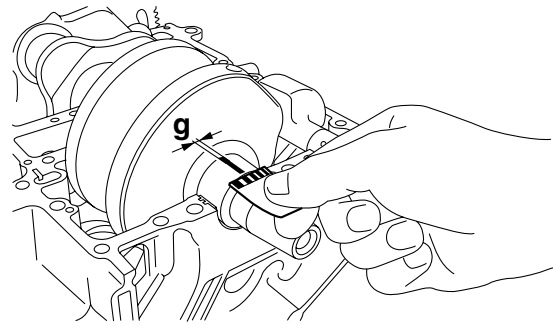

4. Select:

- Crankshaft journal bearings (J₁–J₄)

TIP

- The numbers “A” stamped into the lower crankcase and the numbers “B” stamped into the crankshaft web are used to determine the replacement crankshaft journal bearing sizes.
- J₁–J₄ refer to the bearings shown in the lower crankcase and crankshaft web illustration.
- If J₁–J₄ are the same, use the same size for all of the bearings.

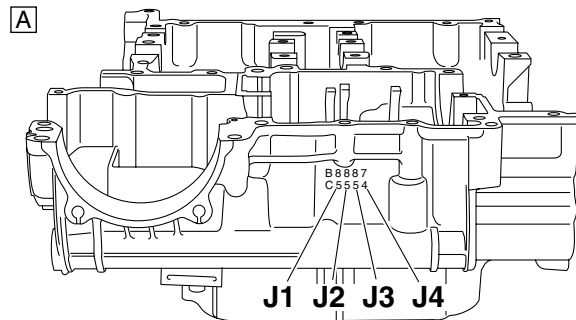
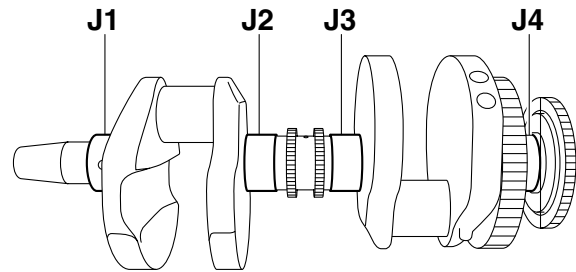

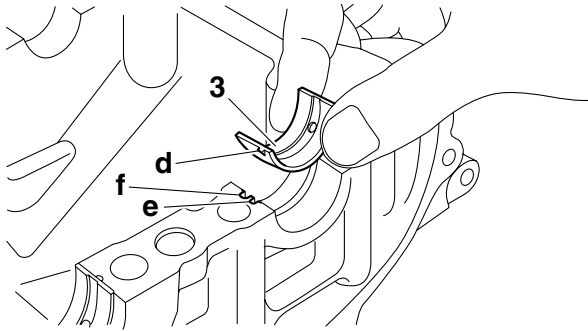

- f. Oil groove
- f. Tighten the bolts to specification in the tightening sequence cast on the crankcase. Refer to "CRANKCASE" on page 5-73.
- g. Remove the lower crankcase and the balancer shaft journal lower bearings.
- h. Measure the compressed Plastigauge® width "g" on each balancer shaft journal. If the balancer shaft-journal-to-balancer shaft-journal-bearing clearance is out of specification, select replacement balancer shaft journal bearings.

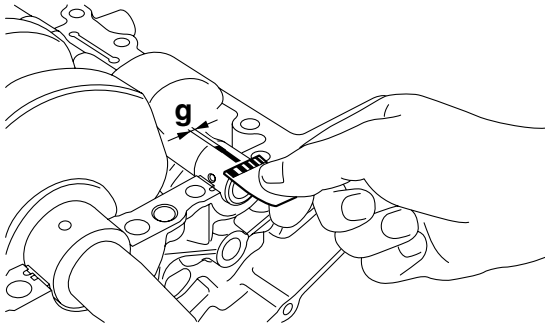

3. Select:

- Balancer shaft journal bearings (J₁-J₄)

TIP

- The numbers "A" stamped into the lower crankcase and the numbers "B" stamped into the balancer shaft web are used to determine the replacement balancer shaft journal bearing sizes.
- J₁-J₄ refer to the bearings shown in the lower crankcase and balancer shaft web illustration.
- If J₁-J₄ are the same, use the same size for all of the bearings.

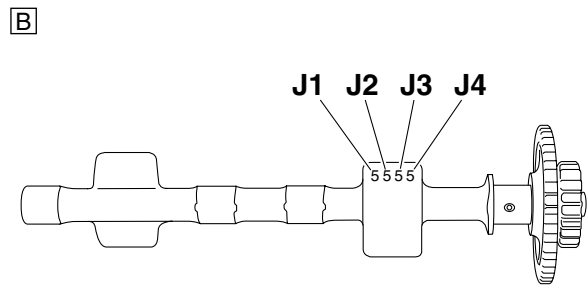
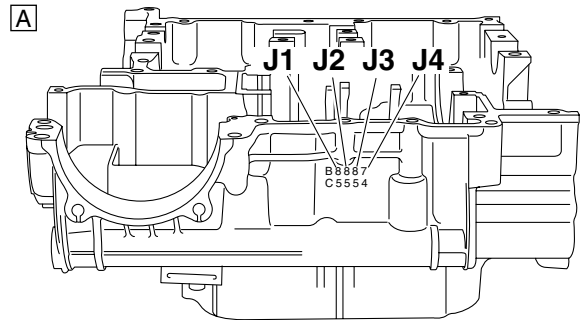
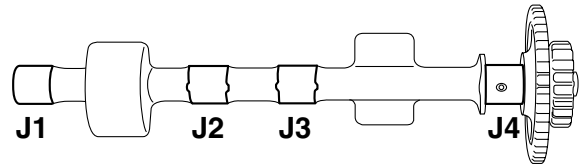

For example, if the lower crankcase J₁ and balancer shaft web J₁ numbers are 8 and 5 respectively, then the bearing size for J₁ is:

$J_1 \text{ (crankcase)} - J_1 \text{ (balancer shaft web)}$ $=$ $8 - 5 = 3 \text{ (brown)}$
--



Bearing color code

1. Blue 2. Black 3. Brown 4. Green
5. Yellow

EAS26200

INSTALLING THE CRANKSHAFT

1. Install:

- Crankshaft journal upper bearings (into the upper crankcase)
- Crankshaft journal lower bearings (into the lower crankcase)

TIP

- Align the projections “a” on the crankshaft journal bearings “1” with the notches “b” in the crankcase.
- Be sure to install each crankshaft journal bearing in its original place.

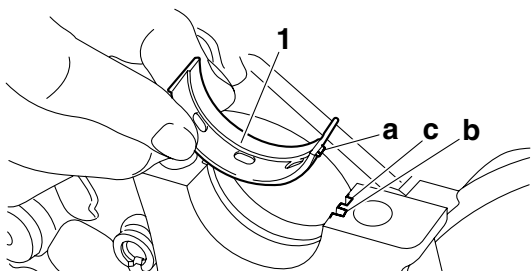

c. Oil groove

2. Install:

- Timing chains “1” (onto the crankshaft sprocket)
- Crankshaft “2”

TIP

- Pass the timing chain through the timing chain cavity.
- To prevent the timing chain from falling into the crankcase, secure it with a wire.

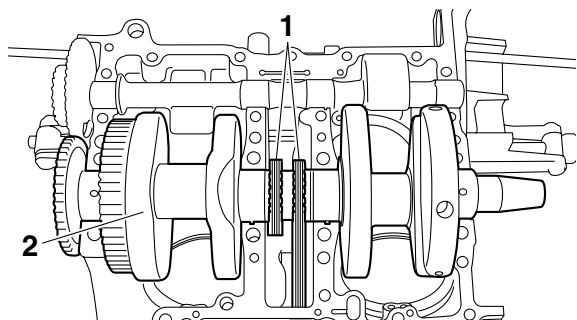

EAS26220

INSTALLING THE BALANCER SHAFT

1. Install:

- Balancer shaft journal upper bearings (into the upper crankcase)
- Balancer shaft journal lower bearings (into the lower crankcase)

TIP

- Align the projections “a” on the balancer shaft journal bearings “1” with the notches “b” in the crankcase.
- Be sure to install each balancer shaft journal bearing in its original place.

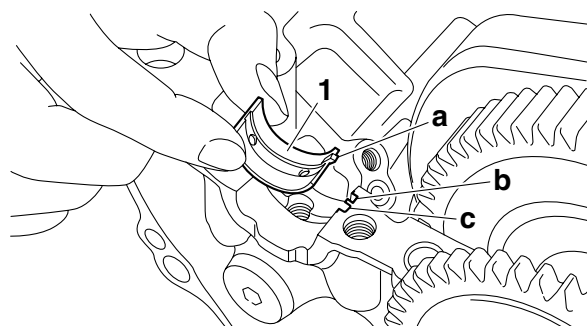

c. Oil groove

2. Install:

- Balancer shaft “1”

TIP

Align the punch mark “a” in the crankshaft with the punch mark “b” in the balancer shaft.

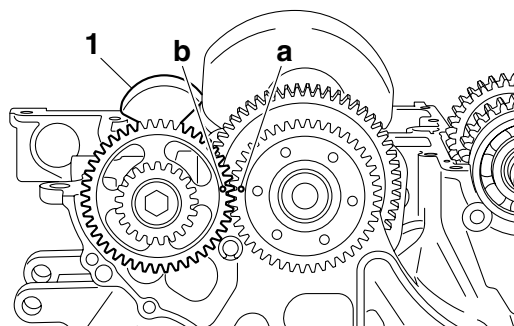

EAS26241

TRANSMISSION

Removing the transmission, shift drum assembly, and shift forks

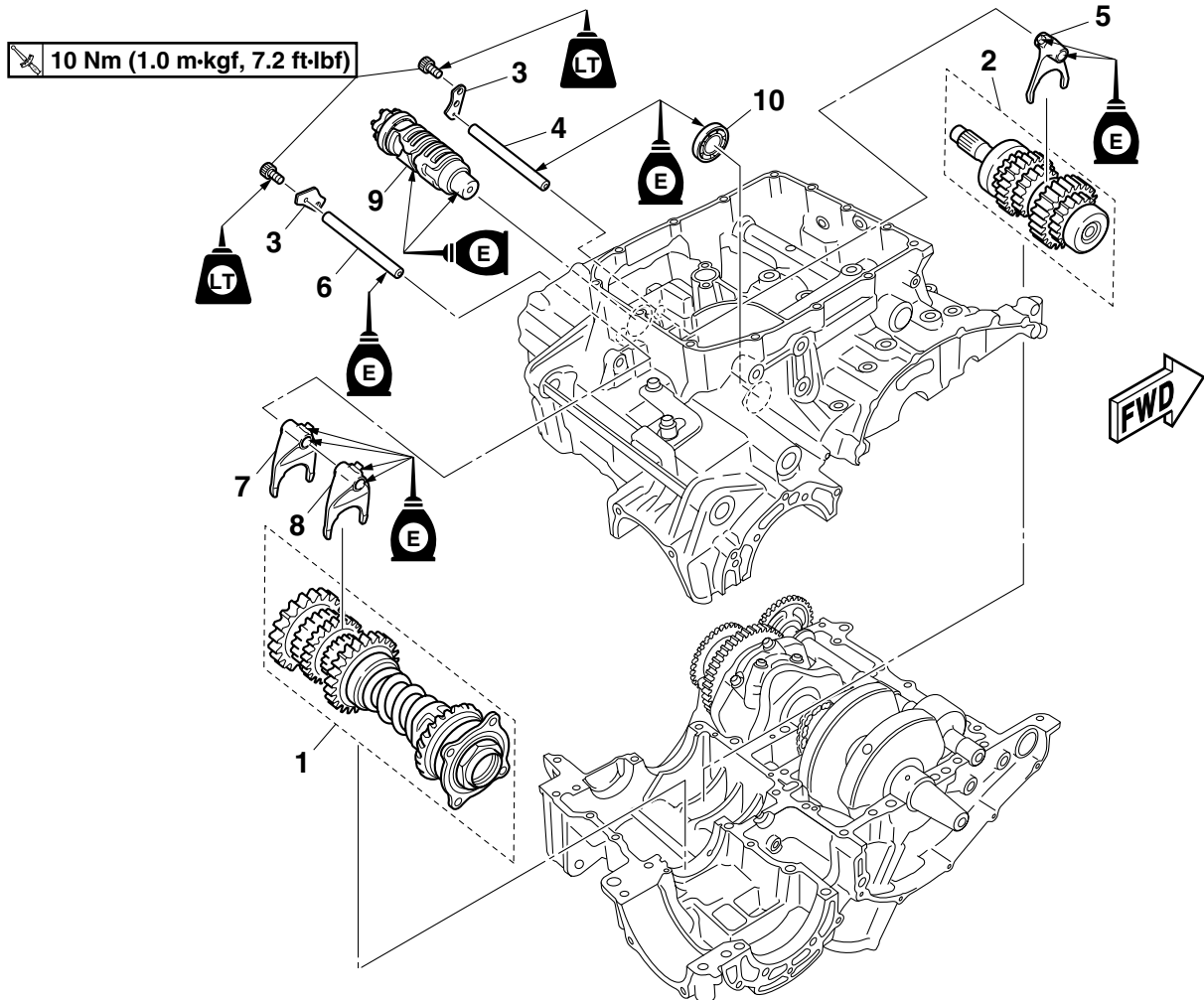

Order	Job/Parts to remove	Q'ty	Remarks
	Crankcase		Separate. Refer to "CRANKCASE" on page 5-73.
1	Drive axle/middle drive pinion gear assembly	1	
2	Main axle assembly	1	
3	Shift drum retainer	2	
4	Long shift fork guide bar	1	
5	Shift fork-C	1	
6	Short shift fork guide bar	1	
7	Shift fork-R	1	
8	Shift fork-L	1	
9	Shift drum assembly	1	
10	Bearing	1	
			For installation, reverse the removal procedure.

Disassembling the main axle assembly

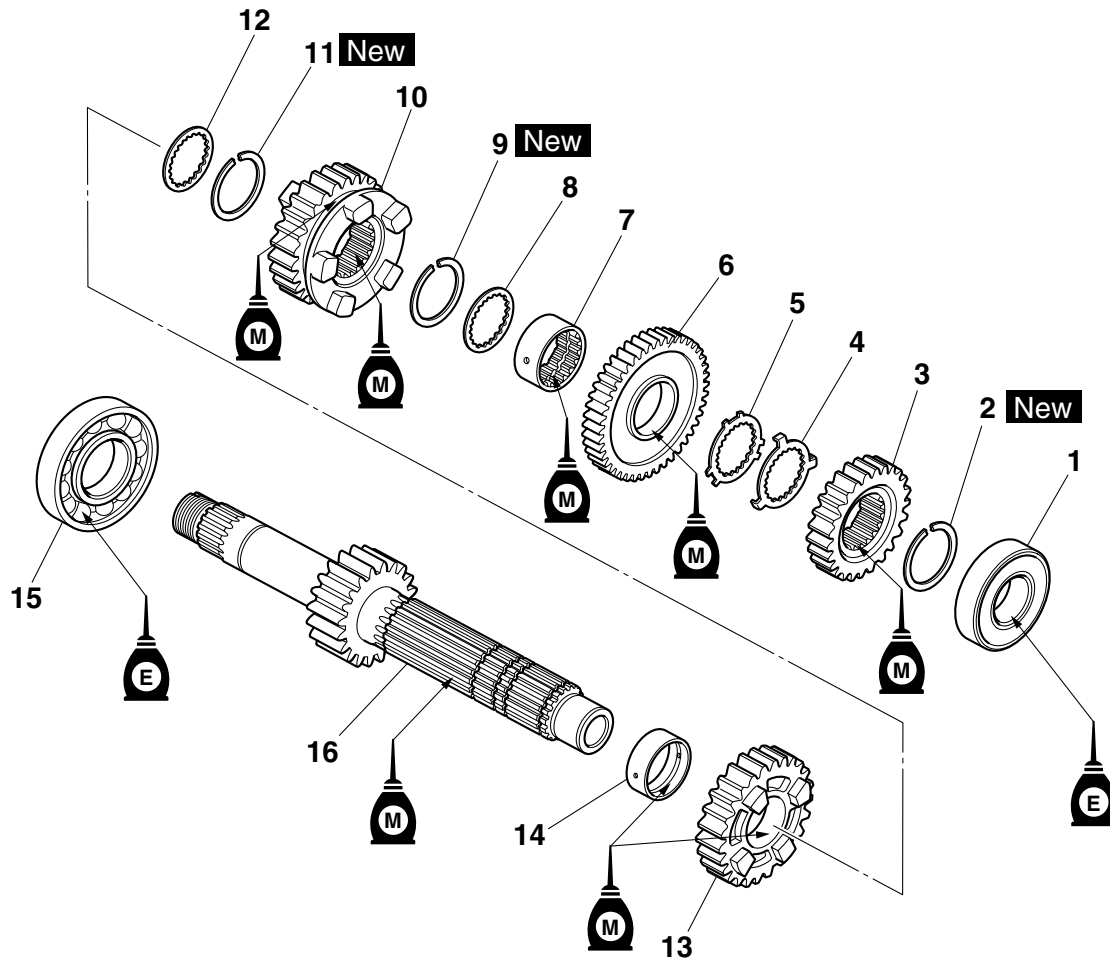

Order	Job/Parts to remove	Q'ty	Remarks
1	Bearing	1	
2	Circlip	1	
3	2nd pinion gear	1	
4	Toothed lock washer	1	
5	Toothed lock washer retainer	1	
6	5th pinion gear	1	
7	Toothed spacer	1	
8	Toothed washer	1	
9	Circlip	1	
10	3rd pinion gear	1	
11	Circlip	1	
12	Toothed washer	1	
13	4th pinion gear	1	
14	Collar	1	
15	Bearing	1	
16	Main axle/1st pinion gear	1	
			For assembly, reverse the disassembly procedure.

Disassembling the drive axle/middle drive pinion gear assembly

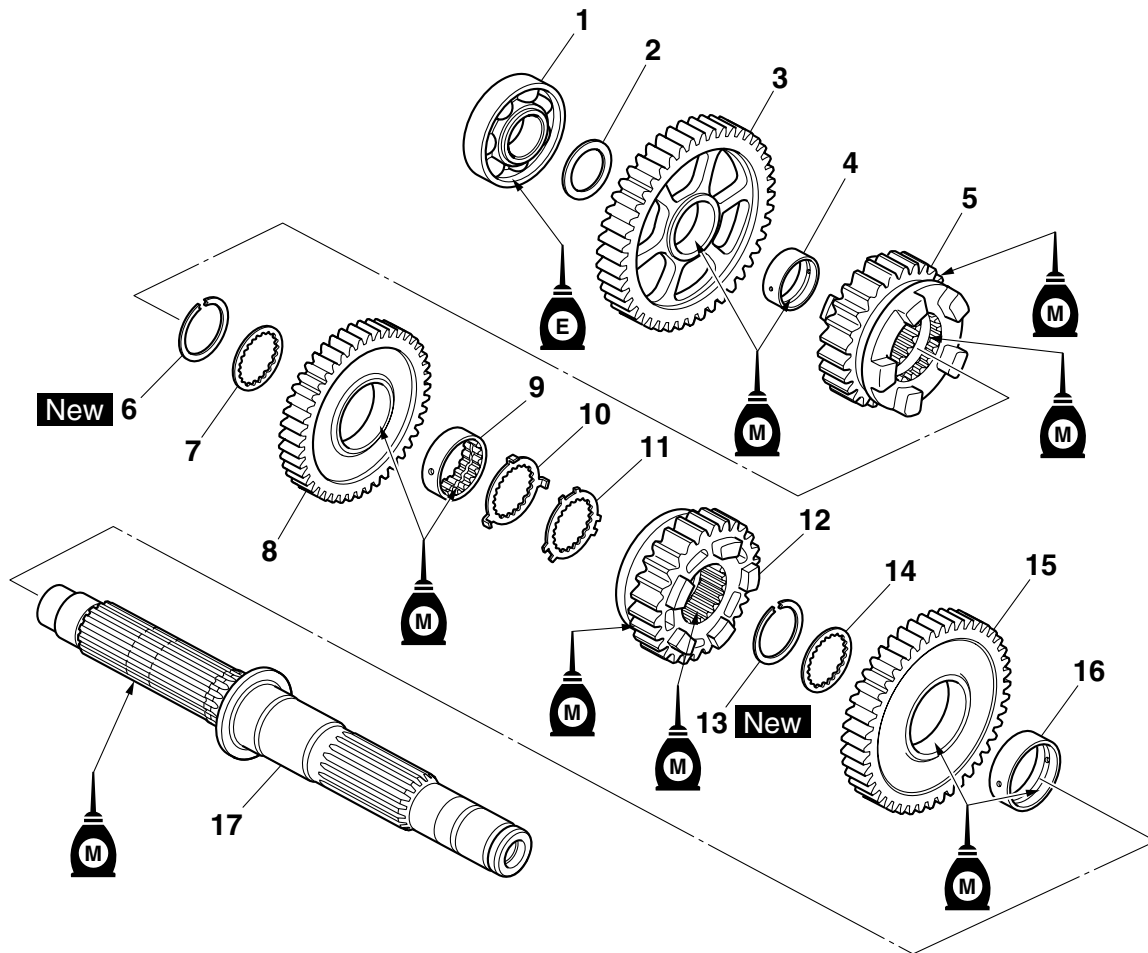

Order	Job/Parts to remove	Q'ty	Remarks
	Middle drive pinion gear assembly		Refer to "MIDDLE GEAR" on page 5-105.
1	Bearing	1	
2	Washer	1	
3	1st wheel gear	1	
4	Collar	1	
5	4th wheel gear	1	
6	Circlip	1	
7	Toothed washer	1	
8	3rd wheel gear	1	
9	Toothed spacer	1	
10	Toothed lock washer	1	
11	Toothed lock washer retainer	1	
12	5th wheel gear	1	
13	Circlip	1	
14	Toothed washer	1	
15	2nd wheel gear	1	
16	Collar	1	

Disassembling the drive axle/middle drive pinion gear assembly

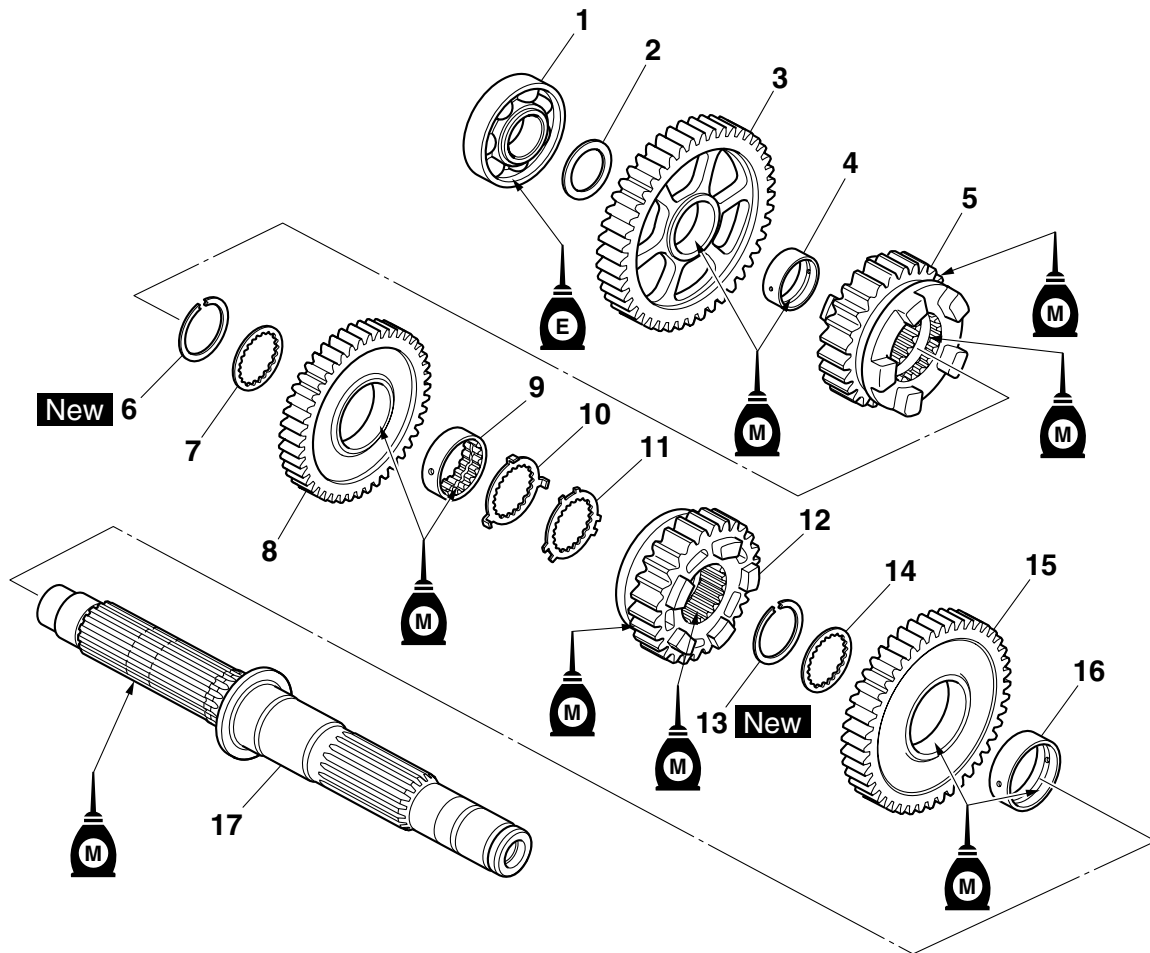

Order	Job/Parts to remove	Q'ty	Remarks
17	Drive axle	1	
			For assembly, reverse the disassembly procedure.

EAS26260

CHECKING THE SHIFT FORKS

The following procedure applies to all of the shift forks.

1. Check:

- Shift fork cam follower "1"
- Shift fork pawl "2"

Bends/damage/scoring/wear → Replace the shift fork.

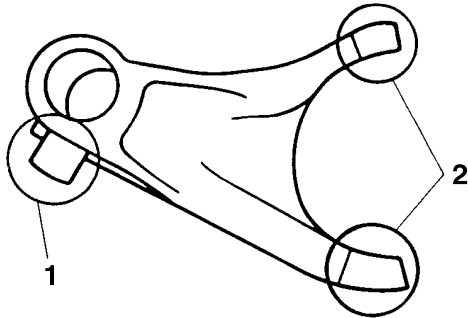

2. Check:

- Shift fork guide bar

Roll the shift fork guide bar on a flat surface.
Bends → Replace.

EWA12840

WARNING

Do not attempt to straighten a bent shift fork guide bar.

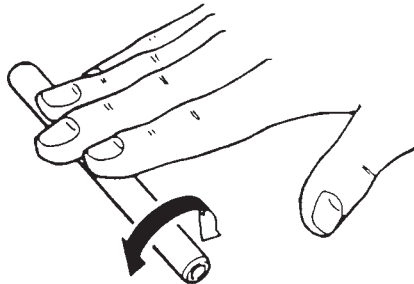

319-010

3. Check:

- Shift fork movement

(along the shift fork guide bar)

Rough movement → Replace the shift forks and shift fork guide bar as a set.

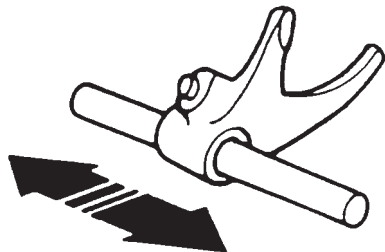

319-011

EAS26270

CHECKING THE SHIFT DRUM ASSEMBLY

1. Check:

- Shift drum groove
Damage/scratches/wear → Replace the shift drum assembly.
- Shift drum segment "1"
Damage/wear → Replace the shift drum assembly.
- Shift drum bearing "2"
Damage/pitting → Replace the shift drum assembly.

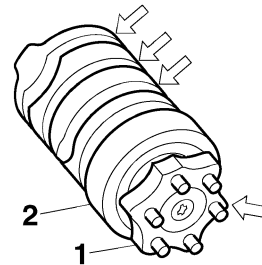

EAS26300

CHECKING THE TRANSMISSION

1. Measure:

- Main axle runout
(with a centering device and dial gauge "1")
Out of specification → Replace the main axle.



Main axle runout limit
0.08 mm (0.0032 in)

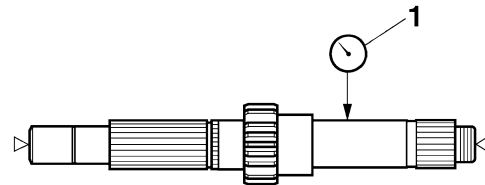

2. Measure:

- Drive axle runout
(with a centering device and dial gauge "1")
Out of specification → Replace the drive axle.



Drive axle runout limit
0.08 mm (0.0032 in)

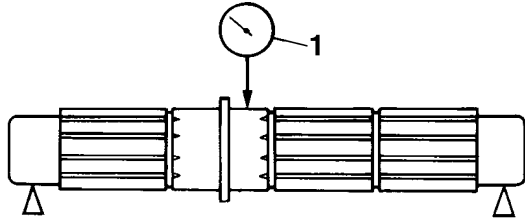

3. Check:

- Transmission gears
Blue discoloration/pitting/wear → Replace the defective gear(s).
- Transmission gear dogs
Cracks/damage/rounded edges → Replace the defective gear(s).

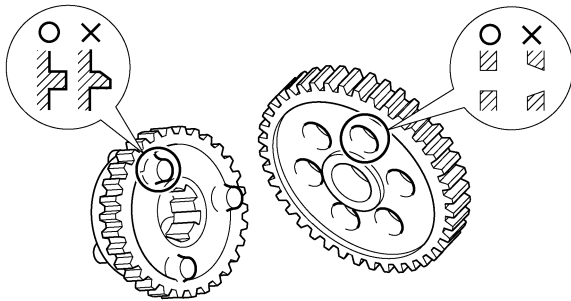

4. Check:

- Transmission gear engagement (each pinion gear to its respective wheel gear)
Incorrect → Reassemble the transmission axle assemblies.

5. Check:

- Transmission gear movement
Rough movement → Replace the defective part(s).

6. Check:

- Circlips
Bends/damage/looseness → Replace.

EAS2S31046

ASSEMBLING THE MAIN AXLE AND DRIVE AXLE

1. Install:

- Circlip "1" **New**

TIP

Install the circlip so that a spline "a" is in the center of the gap between the circlip ends "b" as shown.

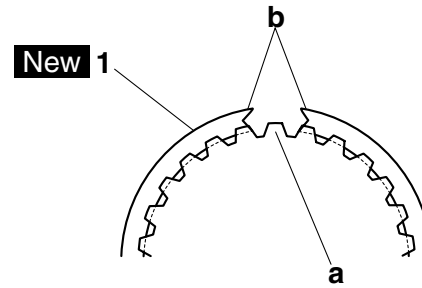

2. Install:

- Toothed lock washer retainer "1"
- Toothed lock washer "2"

TIP

- With the toothed lock washer retainer "1" in the groove "a" in the axle, align the projection on the retainer with an axle spline, and then install the toothed lock washer "2".
- Be sure to align the projection on the toothed lock washer that is between the alignment marks "b" with the alignment mark "c" on the retainer.

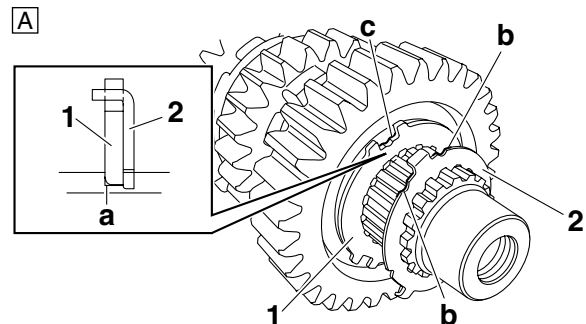

B

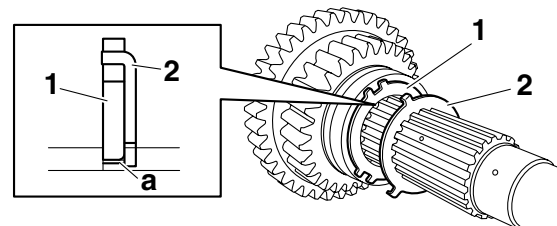

- A. Main axle
- B. Drive axle

3. Install:

- Bearing "1"

TIP

Be sure to install the bearing so that the seal "2" is facing outward.

A

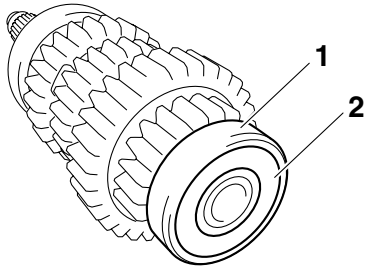

B

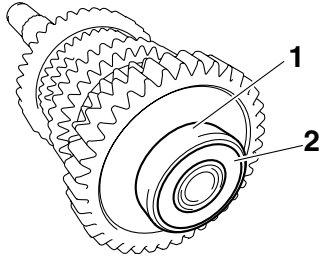

- A. Main axle
- B. Drive axle

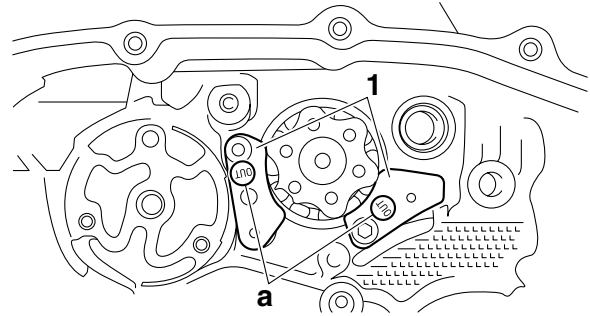

3. Check:

- Transmission
Rough movement → Repair.

TIP

Oil each gear, shaft, and bearing thoroughly.

EAS26350

INSTALLING THE TRANSMISSION

1. Install:

- Shift drum assembly
- Shift fork-L
- Shift fork-R
- Short shift fork guide bar
- Shift fork-C
- Long shift fork guide bar

TIP

The embossed marks on the shift forks should face towards the right side of the engine and be in the following sequence: "R", "C", "L".

2. Install:

- Shift drum retainer "1"



Shift drum retainer bolt
10 Nm (1.0 m·kgf, 7.2 ft·lbf)
LOCTITE®

TIP

Install the shift drum retainer with its "OUT" mark "a" facing outward.

EAS25711

MIDDLE GEAR

Removing the middle driven pinion gear

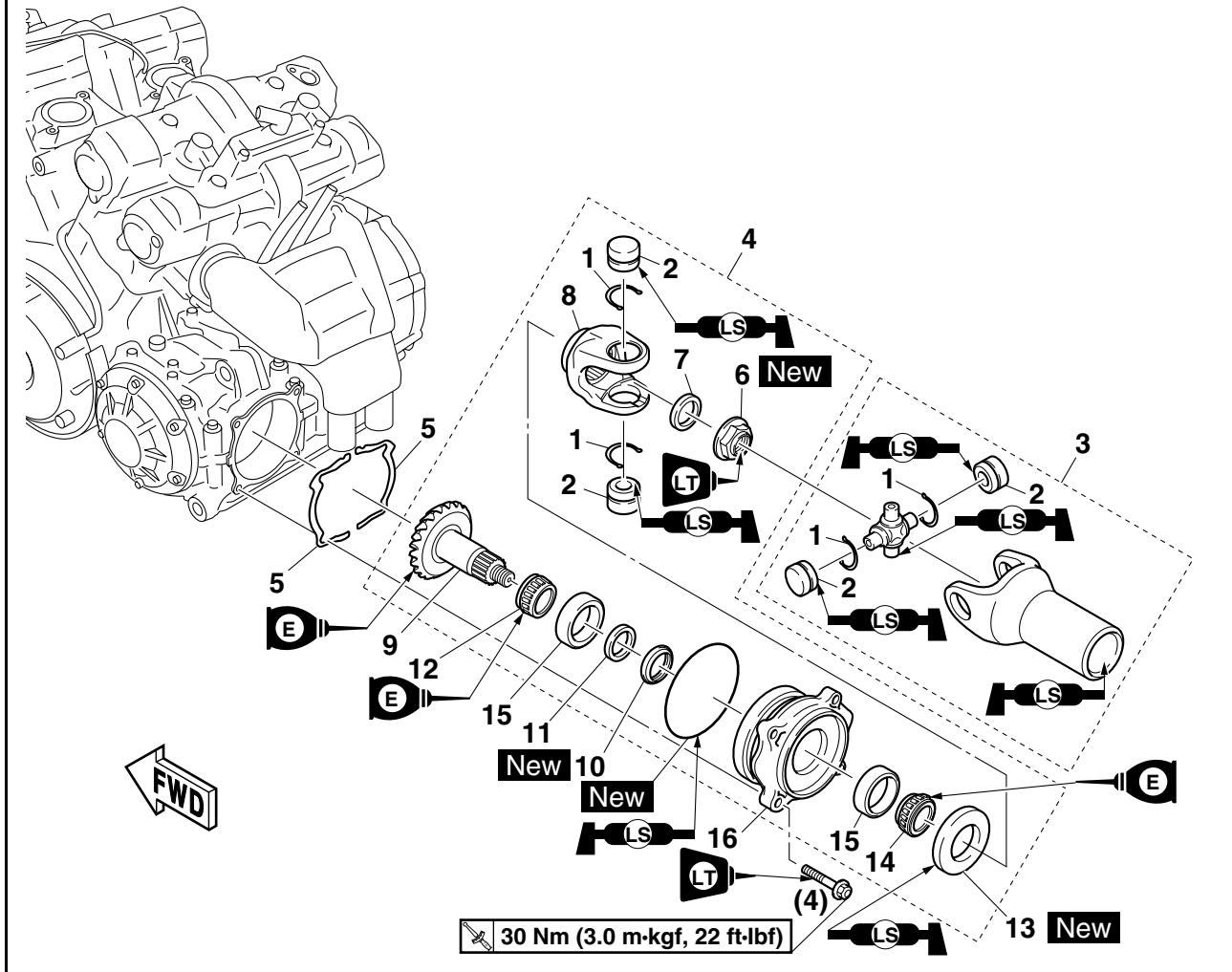

Order	Job/Parts to remove	Q'ty	Remarks
	Engine		Refer to "ENGINE REMOVAL" on page 5-1.
1	Circlip	4	
2	Bearing	4	
3	Universal joint (middle gear side)	1	
4	Middle driven pinion gear assembly	1	
5	Middle driven pinion gear shim		Refer to "ADJUSTING THE MIDDLE GEAR BACKLASH" on page 5-113 and "ALIGNING THE MIDDLE GEAR" on page 5-114.
6	Universal joint yoke nut (middle gear side)	1	
7	Washer	1	
8	Universal joint yoke (middle gear side)	1	
9	Middle driven pinion gear	1	
10	Expander	1	
11	Washer	1	
12	Bearing	1	
13	Oil seal	1	
14	Bearing	1	

Removing the middle driven pinion gear

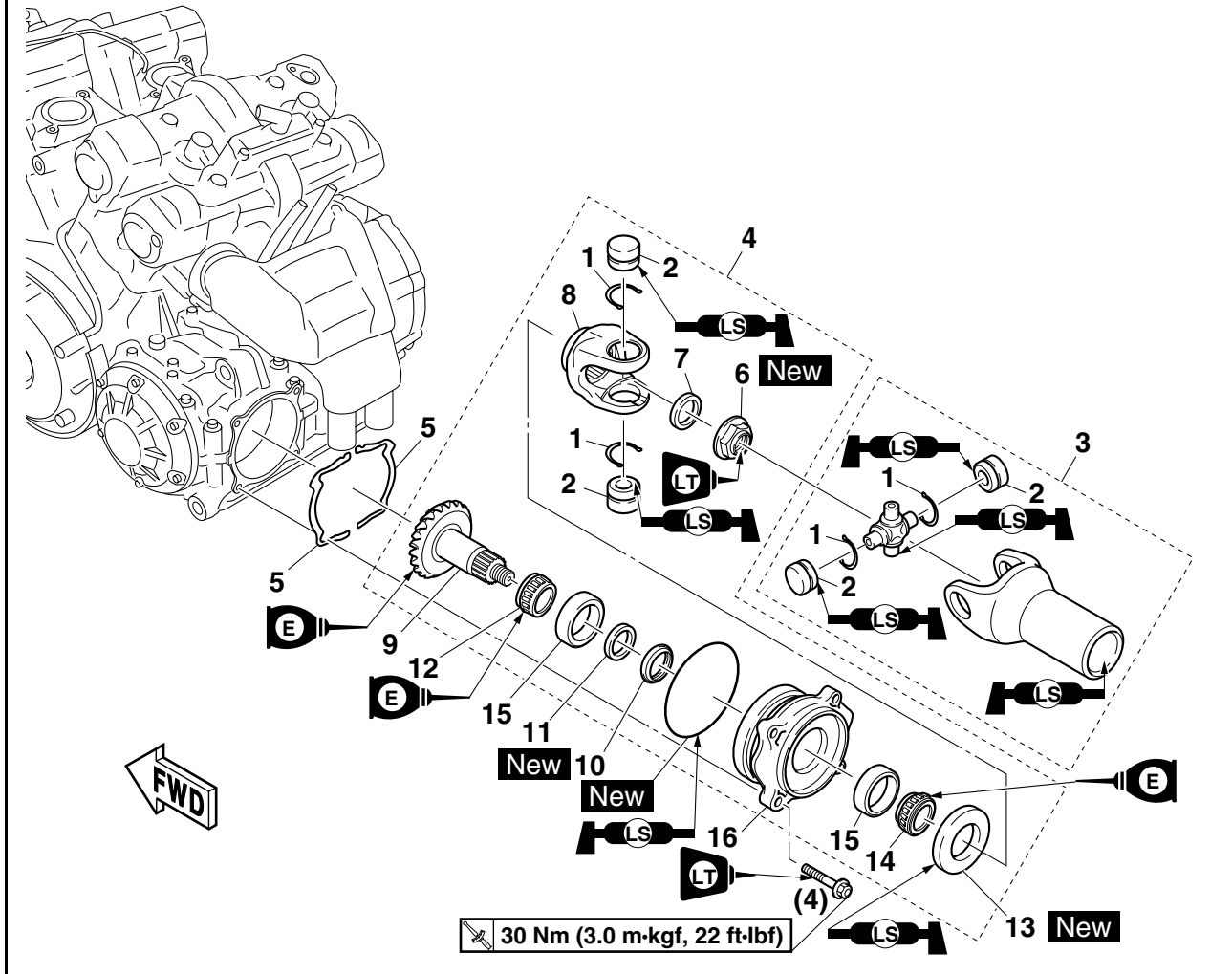

Order	Job/Parts to remove	Q'ty	Remarks
15	Bearing race	2	
16	Middle driven pinion gear bearing housing	1	
			For installation, reverse the removal procedure.

Removing the middle drive pinion gear

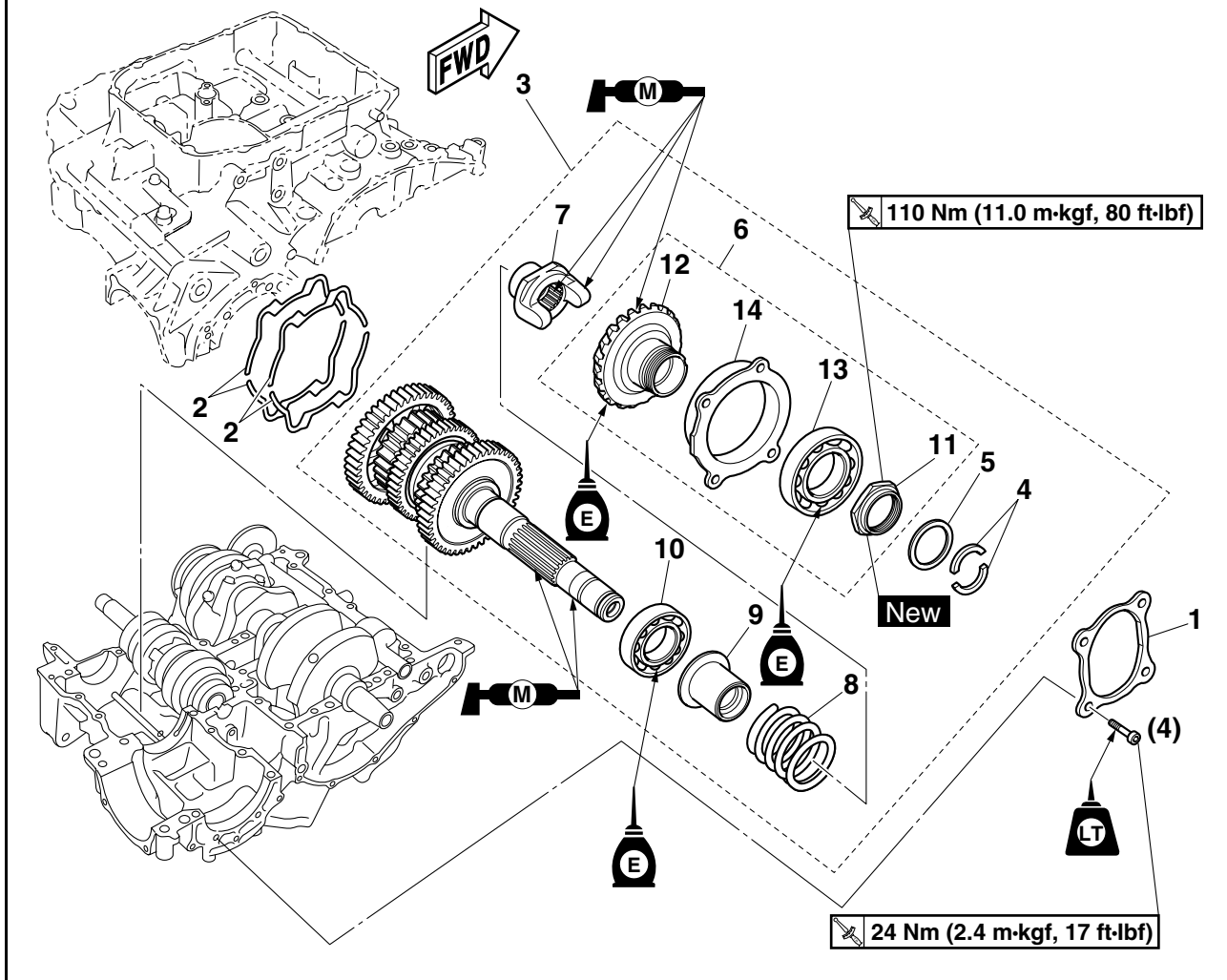

Order	Job/Parts to remove	Q'ty	Remarks
	Crankcase		Separate. Refer to "CRANKCASE" on page 5-73.
1	Middle drive pinion gear bearing retainer	1	
2	Middle drive pinion gear shim		Refer to "ALIGNING THE MIDDLE GEAR" on page 5-114.
3	Drive axle/middle drive pinion gear assembly	1	
4	Spring retainer	2	
5	Washer	1	
6	Middle drive pinion gear assembly	1	
7	Torque damper cam	1	
8	Spring	1	
9	Spring seat	1	
10	Bearing	1	
11	Middle drive pinion gear nut	1	
12	Middle drive pinion gear	1	
13	Bearing	1	

Removing the middle drive pinion gear

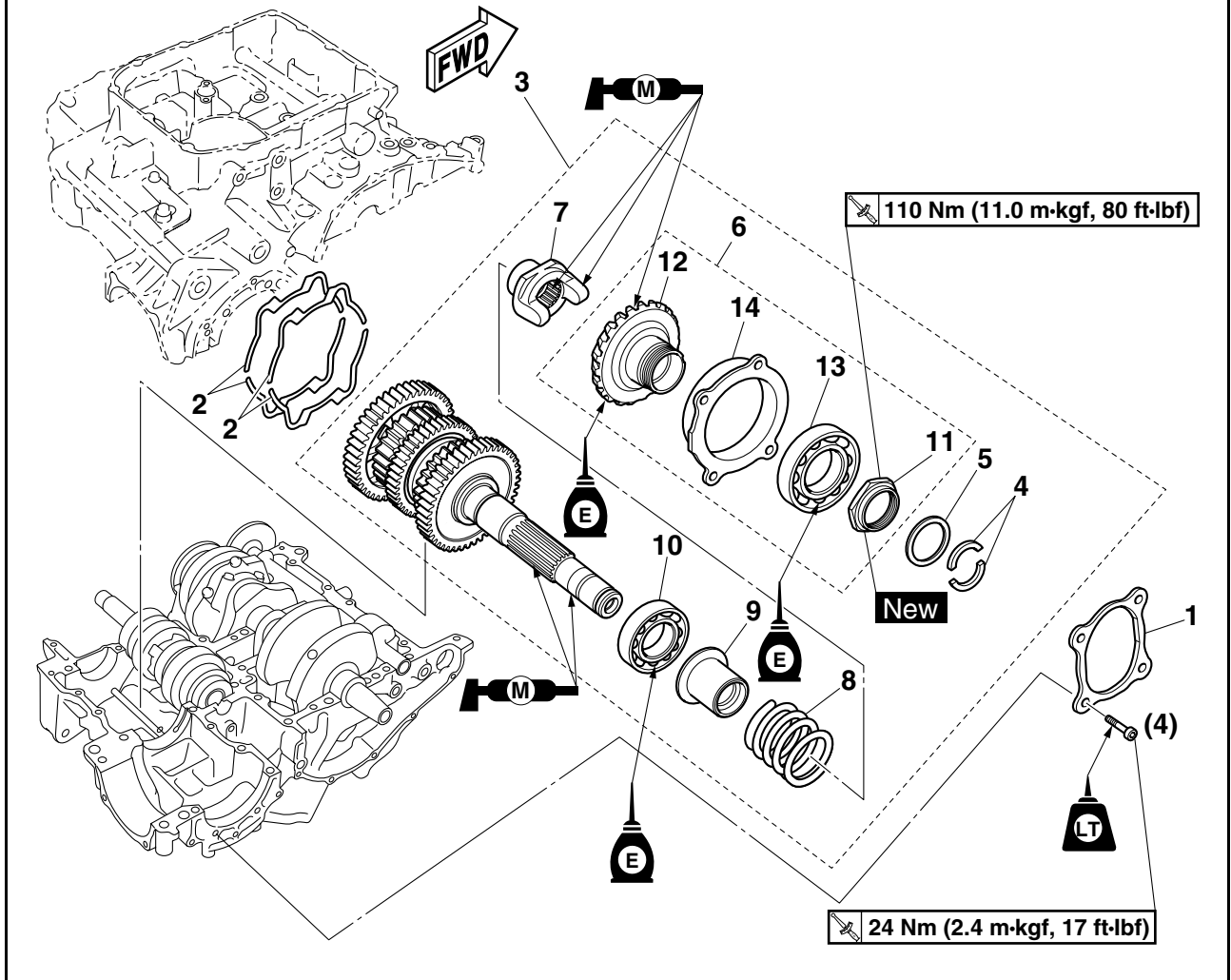

Order	Job/Parts to remove	Q'ty	Remarks
14	Middle drive pinion gear bearing housing	1	
			For installation, reverse the removal procedure.



Middle drive shaft nut wrench (55 mm)
90890-04054
Offset wrench 55 mm
YM-04054

TIP

Wrap the middle drive pinion gear in a folded rag, and then secure it in a vise.

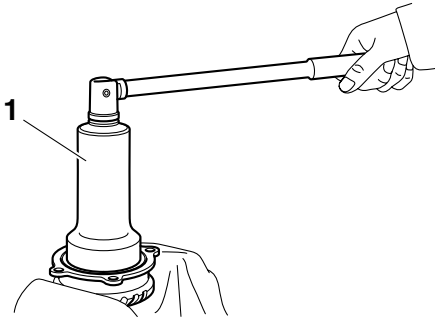

c. Loosen the middle drive pinion gear nut.



EAS2S31052

CHECKING THE MIDDLE DRIVEN PINION GEAR ASSEMBLY

1. Check:
 - Middle driven pinion gear
Galling/pitting/wear → Replace.
2. Check:
 - Bearings
Damage/pitting → Replace.
3. Check:
 - Universal joint movement
Rough movement → Replace the universal joint.

EAS2S31051

CHECKING THE MIDDLE DRIVE PINION GEAR ASSEMBLY

1. Check:
 - Middle drive pinion gear
Galling/pitting/wear → Replace.
2. Check:
 - Torque damper cam surface
Scratches/wear → Replace.
3. Check:
 - Spring
Cracks/damage → Replace.
4. Check:
 - Bearing
Damage/pitting → Replace.

EAS2S31053

ASSEMBLING THE MIDDLE DRIVE PINION GEAR ASSEMBLY

1. Install:
 - Middle drive pinion gear nut **New**



a. Attach the middle drive shaft nut wrench (55 mm) “1”.



Middle drive shaft nut wrench (55 mm)
90890-04054
Offset wrench 55 mm
YM-04054

TIP

Wrap the middle drive pinion gear in a folded rag, and then secure it in a vise.

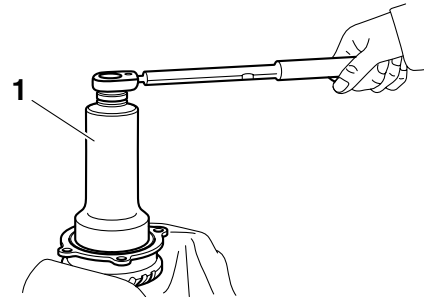

b. Tighten the middle drive pinion gear nut to specification.



Middle drive pinion gear nut
110 Nm (11.0 m·kgf, 80 ft·lbf)

c. Lock the threads with a drift punch.

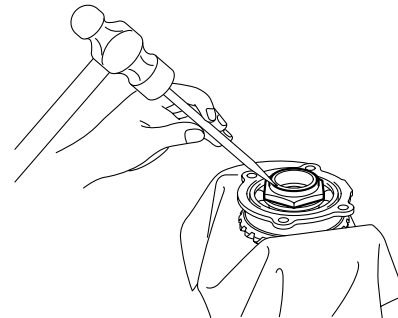

EAS2S31054

INSTALLING THE MIDDLE DRIVE PINION GEAR ASSEMBLY

1. Install:
 - Washer
 - Spring retainers “1”

TIP

While compressing the spring with the damper spring compressor "2", install the washer and spring retainers.

	<p>Damper spring compressor 90890-04090</p>
---	--

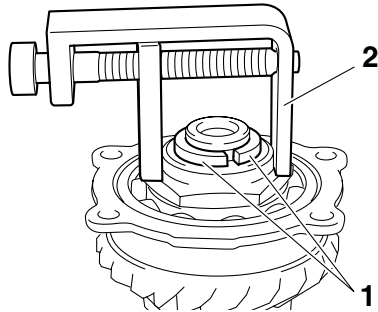

EAS2S31055

ASSEMBLING THE MIDDLE DRIVEN PINION GEAR ASSEMBLY

1. Install:
 - Oil seal "1"
(to the middle driven pinion gear bearing housing)

	<p>Installed depth "a" 4.2–5.8 mm (0.17–0.23 in)</p>
---	---

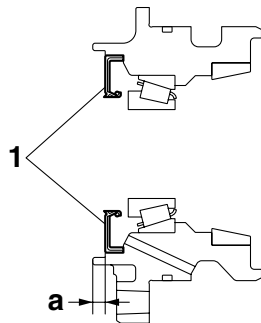

2. Install:
 - Washer "1"

TIP

Install the washer with its "OUT" mark "a" facing outward.

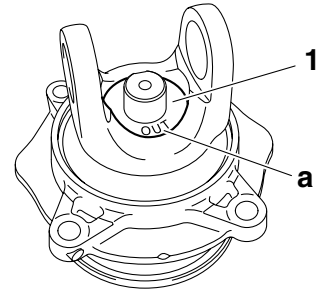

3. Install:
 - Universal joint yoke nut (middle gear side) "1"

New

- a. Tighten the universal joint yoke nut.
(temporarily)

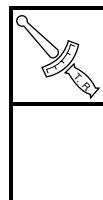
	<p>Universal joint yoke nut (temporarily) 140–300 Nm (14.0–30.0 m·kgf, 100–220 ft·lbf) LOCTITE®</p>
---	--

TIP

- Apply LOCTITE® to the universal joint yoke nut.
- Wrap the middle driven pinion gear bearing housing in a folded rag, and then secure it in a vise.
- While holding the universal joint yoke "2" with the universal joint holder "3", tighten the universal joint yoke nut.
- After tightening the nut, check the operation of the middle driven pinion gear assembly. If there is looseness in the assembly, disassemble it and check if the bearings are installed properly.
- When reassembling the middle driven pinion gear assembly, replace the expander with a new one.

	<p>Universal joint holder 90890-04160 YM-04062</p>
---	---

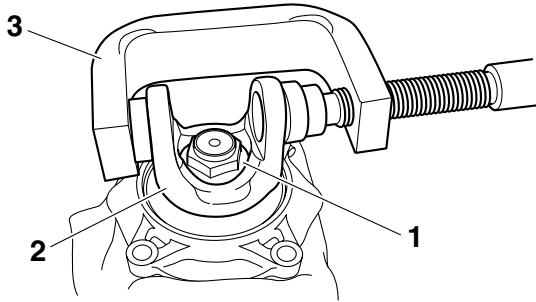

- b. Remove the universal joint holder, and then turn the nut with a torque wrench to check the starting torque.



Middle driven pinion gear starting torque (middle driven pinion gear preload)
0.3–0.6 Nm (0.03–0.06 m·kgf,
0.022–0.43 ft·lbf)

- c. Out of specification → Tighten the nut further.
 d. Repeat steps (a) to (c) until the starting torque is within specification.

TIP

- Be careful not to exceed the specified starting torque.
- If the specified starting torque is exceeded, replace the expander with a new one and reassemble the middle driven pinion gear assembly.

- e. Lock the threads with a drift punch.

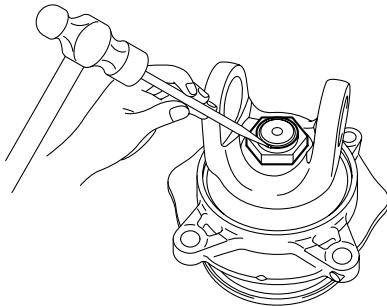

4. Check:
- Middle driven pinion gear operation
 Rough operation → Replace the middle driven pinion gear assembly.
5. Check:
- Middle gear backlash
 Out of specification → Adjust the backlash.

EAS2S31056

INSTALLING THE MIDDLE DRIVEN PINION GEAR ASSEMBLY

1. Install:
- Universal joint (middle gear side)

- a. Fit the universal joint into the yoke.

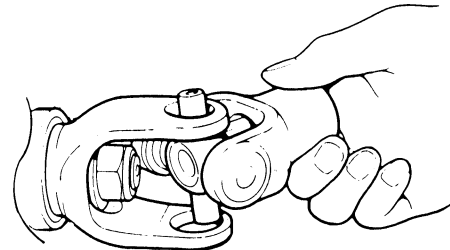

- b. Apply lithium-soap-based grease to the bearings.
 c. Install the bearing “1” into the yoke.

ECA2S31033

NOTICE

Check each bearing. The needle bearings can easily fall out of their races. Slide the yoke back and forth on the bearings; the yoke will not go all the way onto a bearing if a needle is out of place.

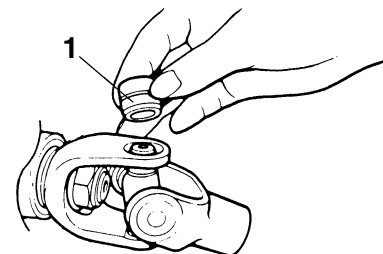

- d. Press each bearing into the yoke using a suitable socket.

TIP

The bearing must be inserted far enough into the yoke so that the circlip can be installed.

- e. Install the circlips “2” into the groove of each bearing.

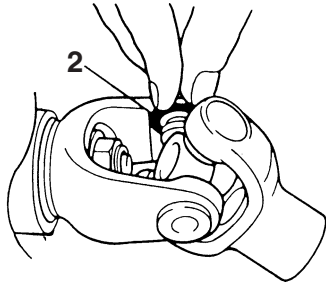

2. Check:

- Universal joint operation
Rough operation → Replace the universal joint or bearing.

TIP

Lift the universal joint “1” and make sure that it falls freely when released.

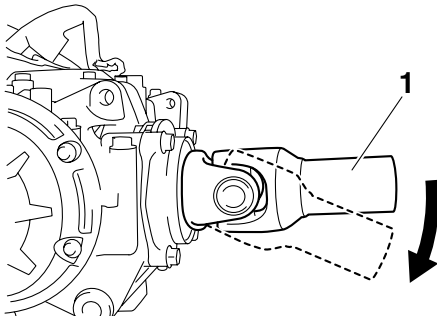

EAS25880

MEASURING THE MIDDLE GEAR BACKLASH

1. Remove:
 - Universal joint (middle gear side)
 - Middle gear side cover
2. Measure:
 - Middle gear backlash
Out of specification → Refer to “ADJUSTING THE MIDDLE GEAR BACKLASH” on page 5-113.



Middle gear backlash
0.05–0.10 mm (0.002–0.004 in)

- a. Hold the middle drive pinion gear “1” with the middle gear backlash tool “2”.

TIP

Finger tighten the middle gear backlash tool bolts.



Middle gear backlash tool
90890-04080

- b. Make sure the dial gauge plunger contacts the measuring point on the centerline of the yoke bearing hole as shown.

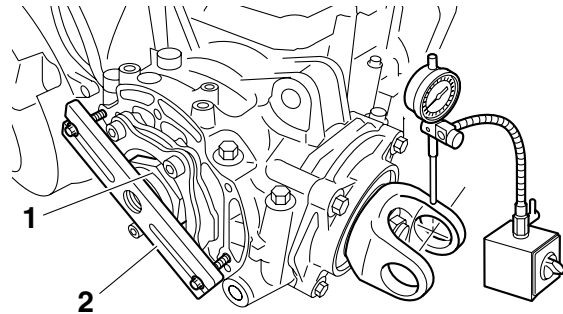

- c. While gently turning the universal joint yoke back and forth, measure the middle gear backlash.

TIP

Measure the middle gear backlash at four positions. Rotate the universal joint yoke 90° each time and observe the reading on the dial gauge.

EAS25900

ADJUSTING THE MIDDLE GEAR BACKLASH

1. Loosen:
 - Middle driven pinion gear bearing housing bolts
2. Remove:
 - Middle driven pinion gear shim(s)
3. Tighten:
 - Middle driven pinion gear bearing housing bolts



Middle driven pinion gear bearing housing bolt
30 Nm (3.0 m·kgf, 22 ft·lbf)

ECA2S31049

NOTICE

Do not overtighten the middle driven pinion gear bearing housing bolts or you may obtain too little middle gear backlash and damage the middle gears. If the bolts are overtightened, loosen them until the crank-case-to-middle-driven-pinion gear-bearing-housing clearance is within specification, as stated below. Then, repeat all of the previous steps.

TIP

- Tighten the middle driven pinion gear bearing housing bolts carefully, one thread turn at a time only. Push in the middle driven pinion gear bearing housing and then tighten the bolts to specification.
- Clearance between the crankcase and the middle driven pinion gear bearing housing should be approximately 2 mm (0.08 in), when measured with a thickness gauge “1”.

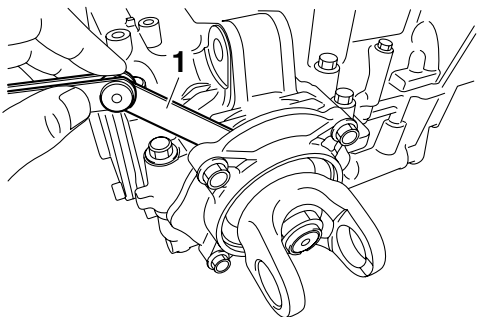

4. Hold the middle drive pinion gear.
5. Turn:
 - Universal joint yoke

TIP

While carefully tightening the middle driven pinion gear bearing housing bolts in stages and in a crisscross pattern, turn the universal joint yoke back and forth until the dial gauge reads 0.05–0.10 mm (0.002–0.004 in).

6. Measure:
 - Crankcase-to-middle-driven-pinion gear-bearing-housing clearance (with a thickness gauge)
7. Select:
 - Middle driven pinion gear shim(s) “1”

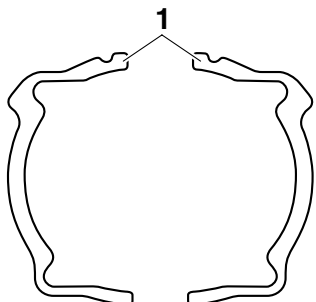

- a. Shims are only available in 0.05 mm increments, therefore round off to the hundredth's digit of the calculated thickness and select the appropriate shim with the following chart.

- b. For example, the clearance between the crankcase and the middle driven pinion gear bearing housing is 0.46 mm. Therefore, the chart instructs you to round off the 6 to 5. Thus, you should use one 0.15 mm and one 0.30 mm shim.

Hundredth	Rounded value
0, 1, 2	0
3, 4, 5, 6, 7	5
8, 9	10

Shims are supplied in the following thicknesses.

Middle driven gear shim
Thickness (mm)
 0.10 0.15 0.20 0.30 0.40 0.50

8. Loosen:
 - Middle driven pinion gear bearing housing bolts
9. Install:
 - Middle driven pinion gear shim(s)
10. Tighten:
 - Middle driven pinion gear bearing housing bolts

Middle driven pinion gear bearing housing bolt
30 Nm (3.0 m·kgf, 22 ft·lbf)
LOCTITE®

11. Measure:
 - Middle gear backlash

Out of specification → Refer to “MEASURING THE MIDDLE GEAR BACKLASH” on page 5-113.

EAS25930

ALIGNING THE MIDDLE GEAR

TIP

Aligning the middle gear is necessary when any of the following parts are replaced:

- Crankcase
- Middle drive pinion gear
- Middle driven pinion gear
- Middle driven pinion gear bearing housing

1. Select:
 - Middle drive pinion gear shim(s) “1”
 - Middle driven pinion gear shim(s) “2”

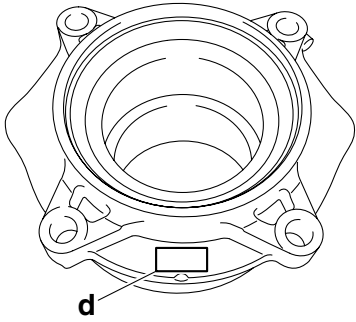

“e”= a numeral on the middle driven pinion gear, to be divided by 100 and either added to or subtracted from “12.00”

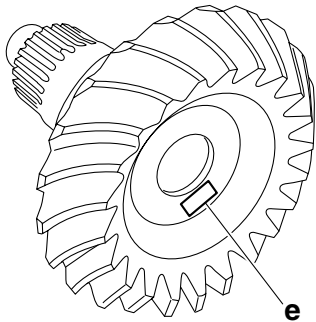

“f”= a numeral on the middle driven pinion gear, to be divided by 100 and either added to or subtracted from “62.00”

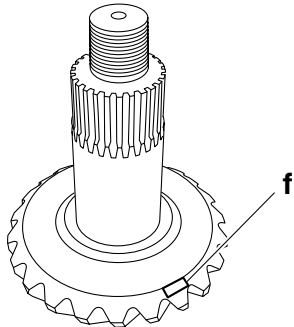

“g”= a numeral on the upper crankcase, to be divided by 100 and added to “103.00”

TIP

If the upper crankcase is marked “00”, “g” is 104.00.

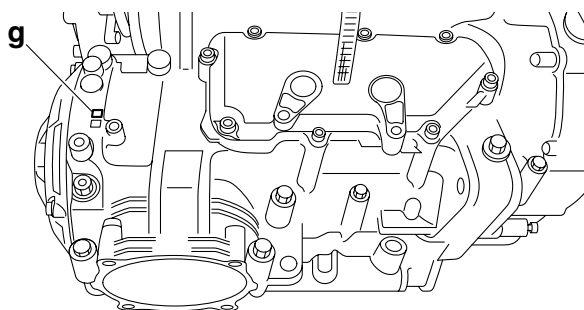

Example:

If the middle driven pinion gear bearing housing is marked “+17”

“d” is 54.72 (i.e., $54.55 + 0.17 = 54.72$)

If the middle driven pinion gear is marked “+03”

“e” is 12.03 (i.e., $12.00 + 0.03 = 12.03$)

If the middle driven pinion gear is marked “-02”

“f” is 61.98 (i.e., $62.00 - 0.02 = 61.98$)

If the upper crankcase is marked “93”

“g” is 103.93 (i.e., $103.00 + 0.93 = 103.93$)

TIP

If the upper crankcase is marked “00”, “g” is 104.00.

“B” = $54.72 - 12.03 + 61.98 - 103.93 = 0.74$

Round off to the hundredths digit and select the appropriate shim(s).

TIP

In the above example, the calculated number is 0.74. The chart instructs you to round off the 4 to 5. Thus, the shim thickness is 0.75 mm.

Hundredths	Rounded value
0, 1, 2	0
3, 4, 5, 6, 7	5
8, 9	10

Shims are supplied in the following thicknesses.

	Middle driven pinion gear shim
	Thickness (mm) 0.10 0.15 0.20 0.30 0.40 0.50



COOLING SYSTEM

RADIATORS	6-1
CHECKING THE RADIATORS	6-4
INSTALLING THE RADIATOR ASSEMBLY	6-4
OIL COOLER	6-5
CHECKING THE OIL COOLER	6-6
INSTALLING THE OIL COOLER	6-6
THERMOSTAT	6-7
CHECKING THE THERMOSTAT.....	6-9
INSTALLING THE THERMOSTAT ASSEMBLY	6-9
WATER PUMP	6-11
DISASSEMBLING THE WATER PUMP.....	6-13
CHECKING THE WATER PUMP	6-13
ASSEMBLING THE WATER PUMP.....	6-13
INSTALLING THE WATER PUMP	6-14

EAS2S31078

RADIATORS

Removing the radiator assembly

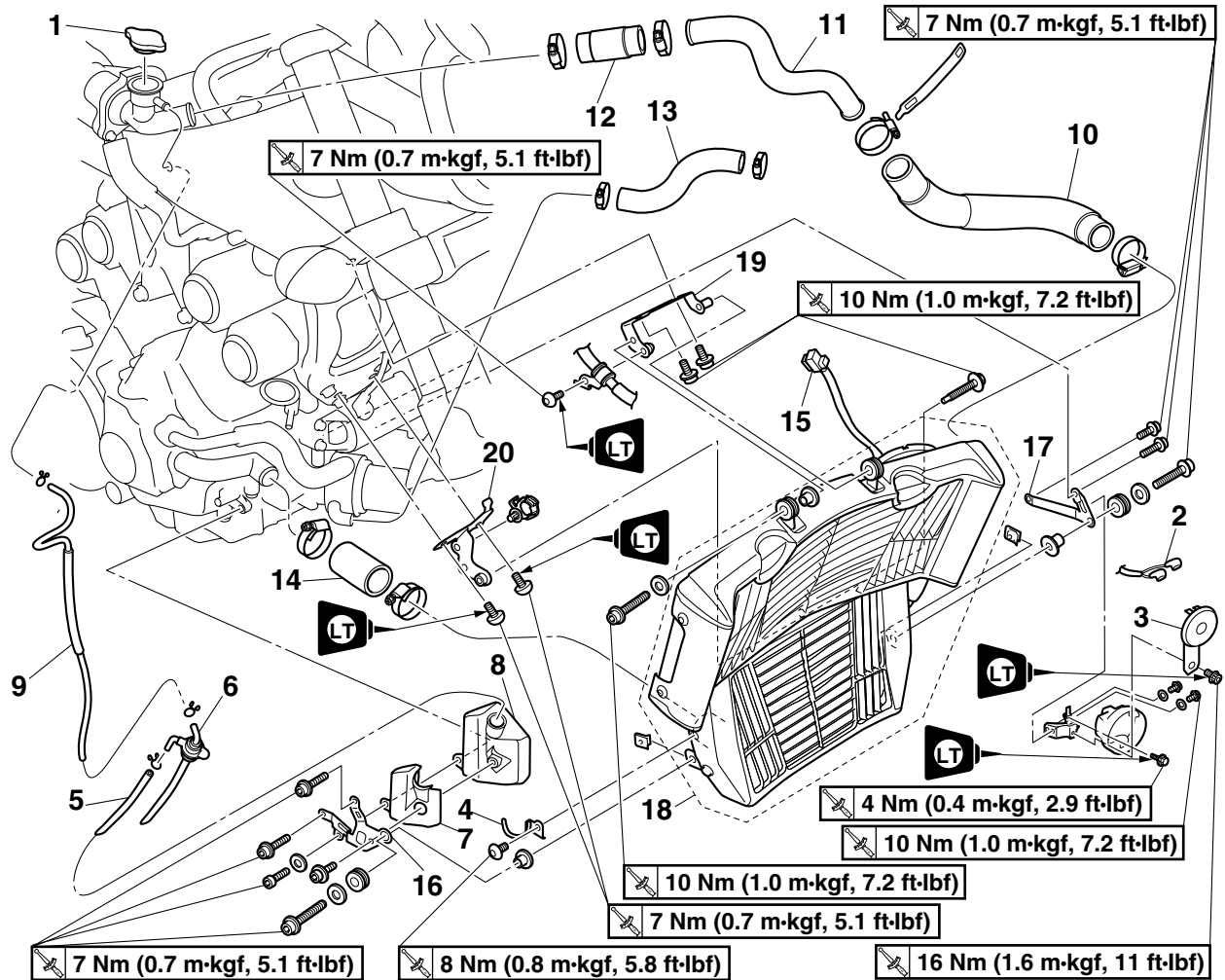

Order	Job/Parts to remove	Q'ty	Remarks
	Coolant		Drain. Refer to "CHANGING THE COOLANT" on page 3-19.
	Throttle bodies		Refer to "THROTTLE BODIES" on page 7-11.
	Front exhaust pipes		Refer to "ENGINE REMOVAL" on page 5-1.
1	Radiator cap	1	
2	Horn connector	2	Disconnect.
3	Horn	1	
4	Coolant reservoir cap guide	1	
5	Coolant reservoir breather hose	1	
6	Coolant reservoir cap	1	
7	Coolant reservoir cover	1	
8	Coolant reservoir	1	
9	Coolant reservoir hose	1	
10	Upper radiator inlet hose	1	
11	Upper radiator inlet pipe	1	

Removing the radiator assembly

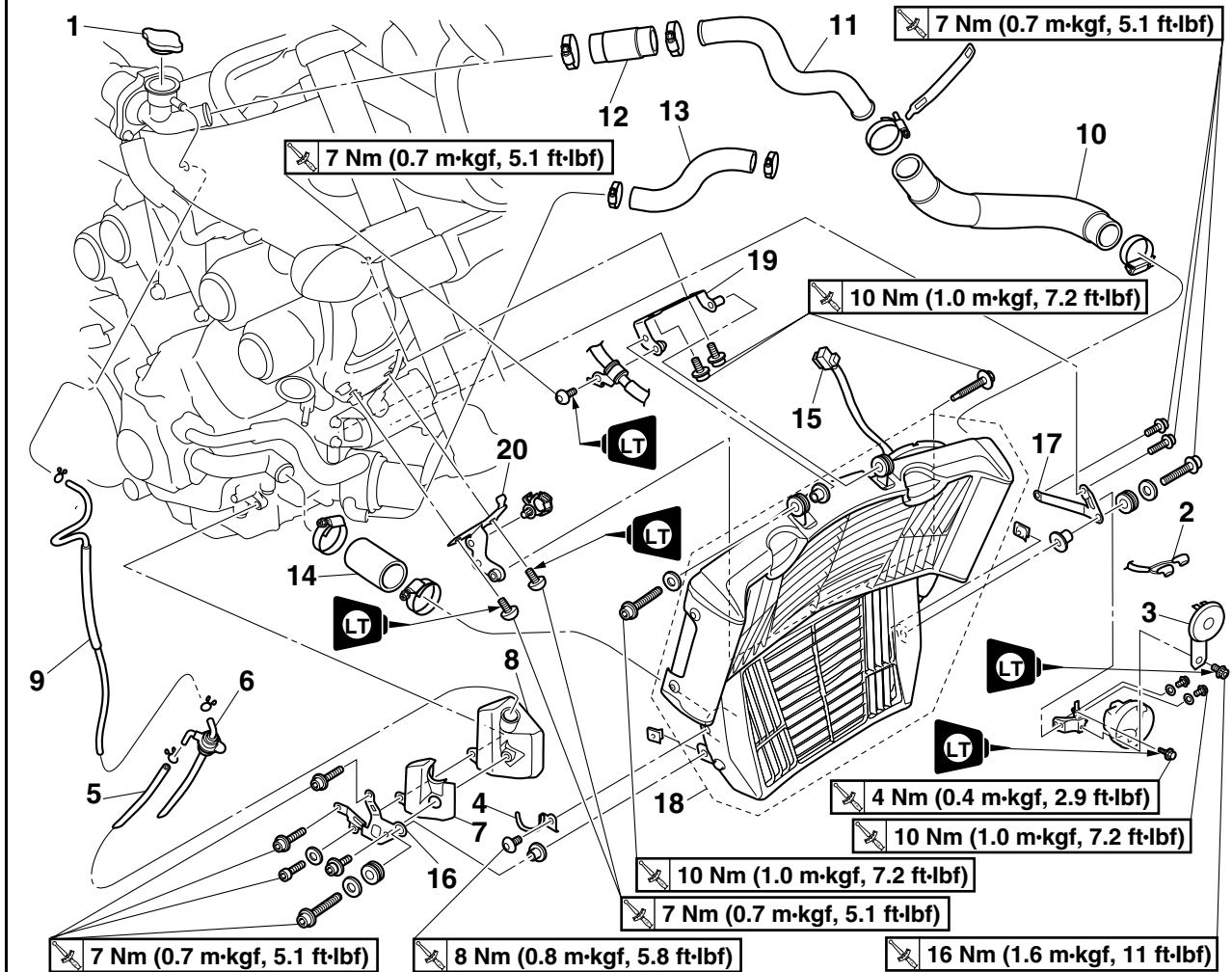

Order	Job/Parts to remove	Q'ty	Remarks
12	Thermostat outlet hose	1	
13	Oil cooler outlet hose	1	
14	Lower radiator outlet hose	1	
15	Radiator fan motor sub-wire harness coupler	1	Disconnect.
16	Right lower radiator bracket	1	
17	Left lower radiator bracket	1	
18	Radiator assembly	1	
19	Upper radiator bracket	1	
20	Upper/lower radiator bracket	1	
			For installation, reverse the removal procedure.

Disassembling the radiators

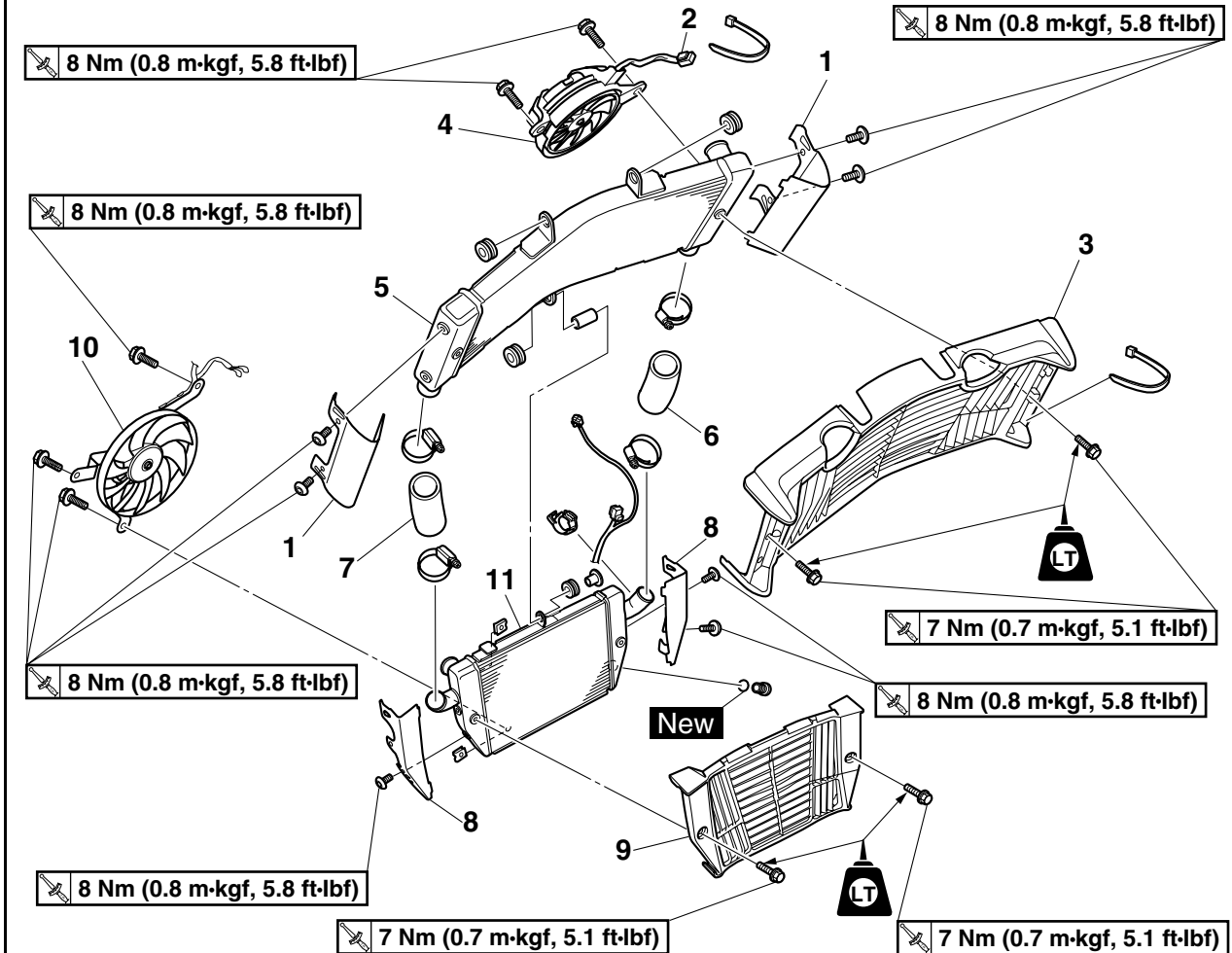

Order	Job/Parts to remove	Q'ty	Remarks
1	Upper radiator side panel	2	
2	Sub radiator fan motor coupler	1	Disconnect.
3	Upper radiator cover	1	
4	Sub radiator fan	1	
5	Upper radiator	1	
6	Left lower radiator inlet hose	1	
7	Right lower radiator inlet hose	1	
8	Lower radiator side panel	2	
9	Lower radiator cover	1	
10	Main radiator fan	1	
11	Lower radiator	1	
			For assembly, reverse the disassembly procedure.

EAS26410

OIL COOLER

Removing the oil cooler

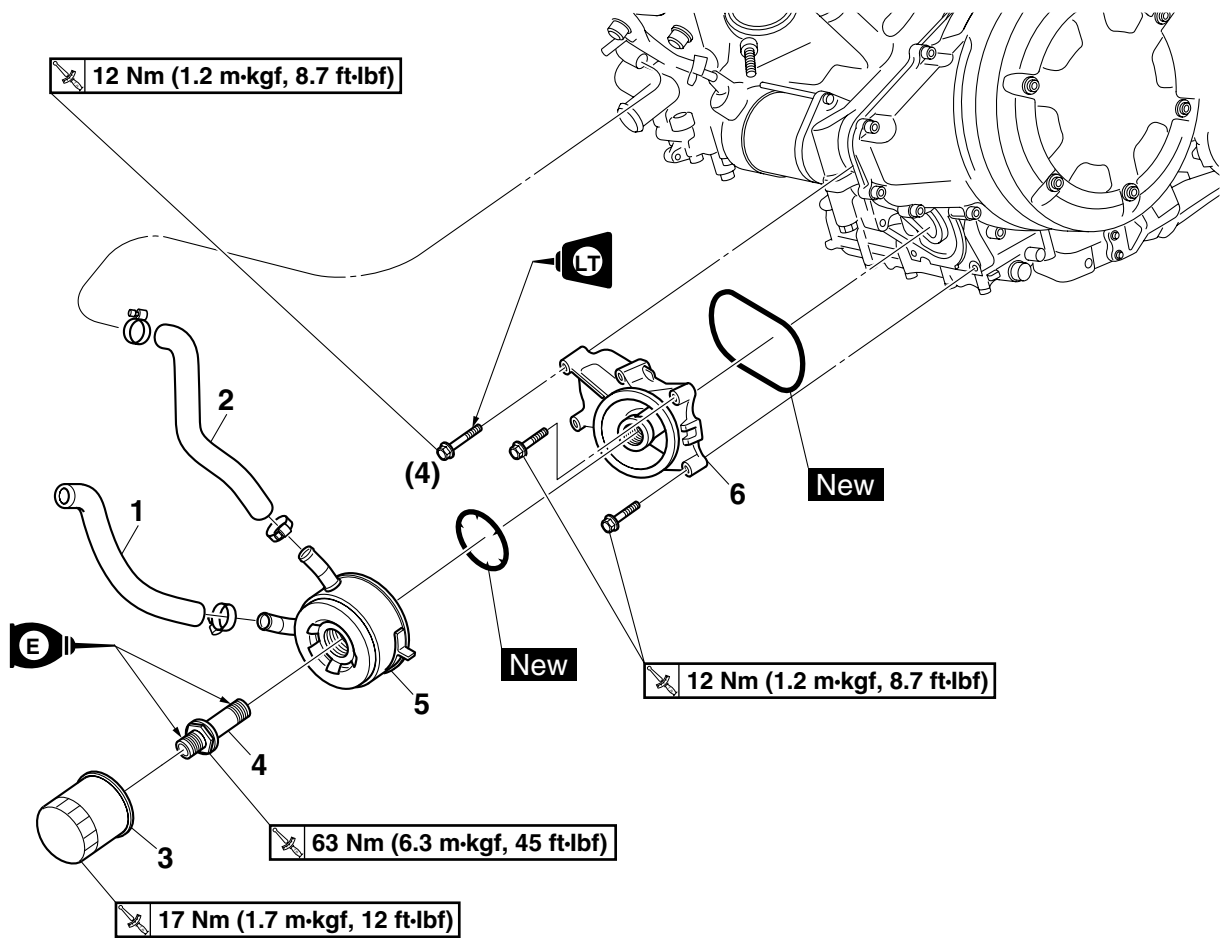

Order	Job/Parts to remove	Q'ty	Remarks
	Engine oil		Drain. Refer to "CHANGING THE ENGINE OIL" on page 3-11.
	Coolant		Drain. Refer to "CHANGING THE COOLANT" on page 3-19.
	Radiator assembly		Refer to "RADIATORS" on page 6-1.
1	Oil cooler outlet hose	1	
2	Oil cooler inlet hose	1	
3	Oil filter cartridge	1	
4	Oil cooler union bolt	1	
5	Oil cooler	1	
6	Oil cooler adapter	1	
			For installation, reverse the removal procedure.

EAS26420

CHECKING THE OIL COOLER

1. Check:
 - Oil cooler
Cracks/damage → Replace.
2. Check:
 - Oil cooler inlet hose
 - Oil cooler outlet hose
 - Oil cooler adapter
Cracks/damage/wear → Replace.

EAS26430

INSTALLING THE OIL COOLER

1. Clean:
 - Mating surfaces of the oil cooler and the oil cooler adapter
(with a cloth dampened with lacquer thinner)
2. Install:
 - O-ring **New**
 - Oil cooler adapter

TIP

To hold the O-ring in place during installation, apply Three bond 1541® to six points shown in the illustration.

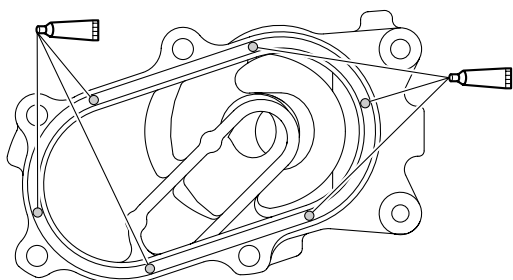

3. Install:
 - O-ring **New**
 - Oil cooler
 - Oil cooler union bolt



Oil cooler union bolt
63 Nm (6.3 m·kgf, 45 ft·lbf)

TIP

- Before installing the oil cooler, lubricate the oil cooler union bolt with a thin coat of engine oil.
- Make sure the O-ring is positioned properly.

4. Install:
 - Oil cooler hoses
Refer to “COOLING SYSTEM DIAGRAMS” on page 2-43.

5. Install:
 - Oil filter cartridge
Refer to “CHANGING THE ENGINE OIL” on page 3-11.



Oil filter cartridge
17 Nm (1.7 m·kgf, 12 ft·lbf)

6. Fill:
 - Cooling system
(with the specified amount of the recommended coolant)
Refer to “CHANGING THE COOLANT” on page 3-19.
 - Crankcase
(with the specified amount of the recommended engine oil)
Refer to “CHANGING THE ENGINE OIL” on page 3-11.
7. Check:
 - Cooling system
Leaks → Repair or replace any faulty part.
8. Measure:
 - Radiator cap opening pressure
Below the specified pressure → Replace the radiator cap.
Refer to “CHECKING THE RADIATORS” on page 6-4.

EAS26440

THERMOSTAT

Removing the thermostat assembly

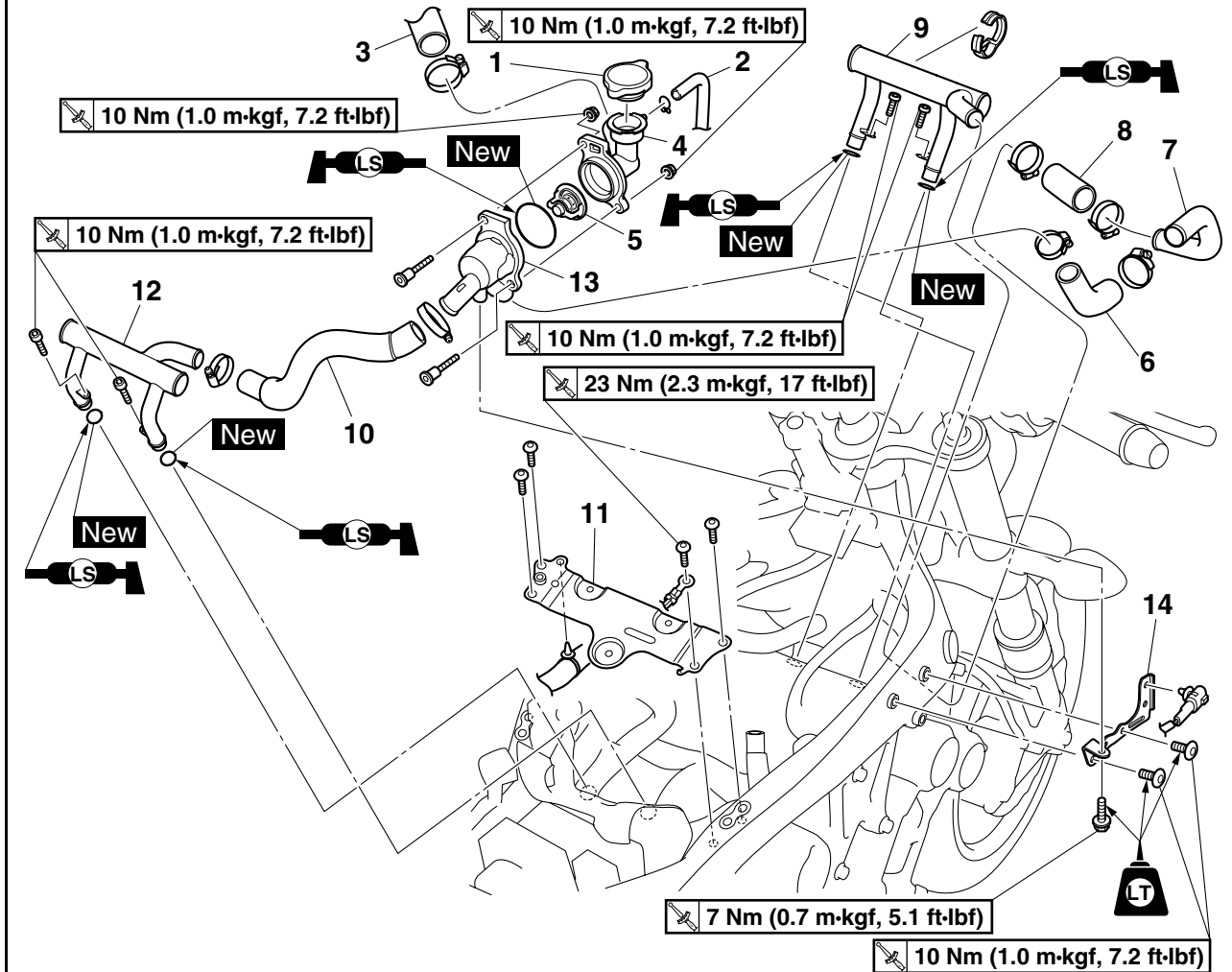

Order	Job/Parts to remove	Q'ty	Remarks
	Coolant		Drain. Refer to "CHANGING THE COOLANT" on page 3-19.
	Throttle bodies		Refer to "THROTTLE BODIES" on page 7-11.
	Brake hose holder		Refer to "ABS (ANTI-LOCK BRAKE SYSTEM)" on page 4-55.
1	Radiator cap	1	
2	Coolant reservoir hose	1	Disconnect.
3	Thermostat outlet hose	1	Disconnect.
4	Thermostat cover/radiator filler pipe	1	
5	Thermostat	1	
6	Thermostat inlet hose 2 (front cylinders)	1	
7	Thermostat inlet pipe 2 (front cylinders)	1	
8	Thermostat inlet hose 1 (front cylinders)	1	
9	Thermostat inlet pipe 1 (front cylinders)	1	
10	Thermostat inlet hose (rear cylinders)	1	

Removing the thermostat assembly

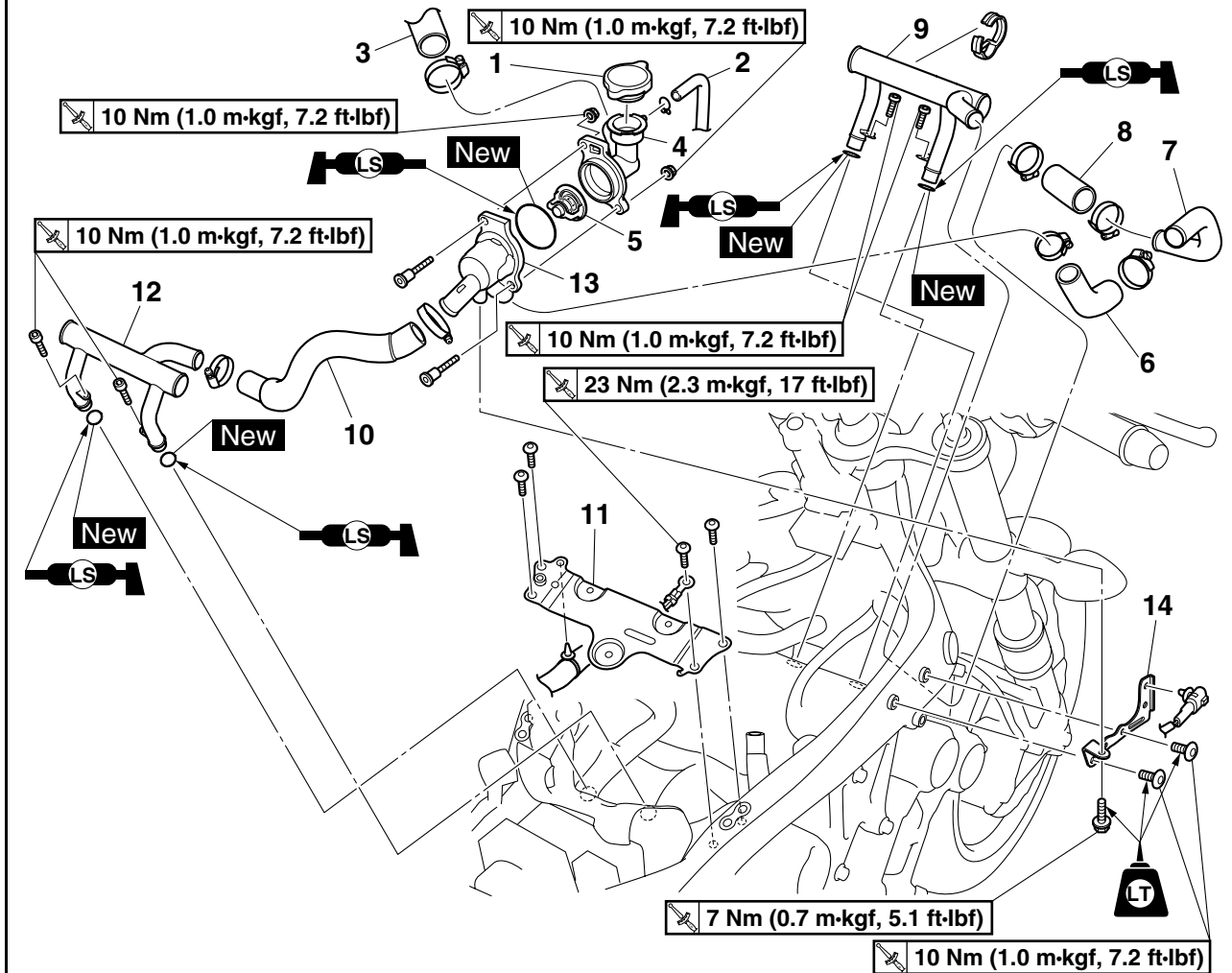

Order	Job/Parts to remove	Q'ty	Remarks
11	Battery box bracket	1	
12	Thermostat inlet pipe (rear cylinders)	1	
13	Thermostat housing	1	
14	Thermostat housing bracket	1	
			For installation, reverse the removal procedure.

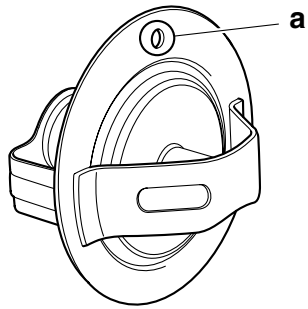

4. Fill:

- Cooling system
(with the specified amount of the recommended coolant)
Refer to “CHANGING THE COOLANT” on page 3-19.

5. Check:

- Cooling system
Leaks → Repair or replace any faulty part.

6. Measure:

- Radiator cap opening pressure
Below the specified pressure → Replace the radiator cap.
Refer to “CHECKING THE RADIATORS” on page 6-4.

EAS26500

WATER PUMP

Removing the water pump

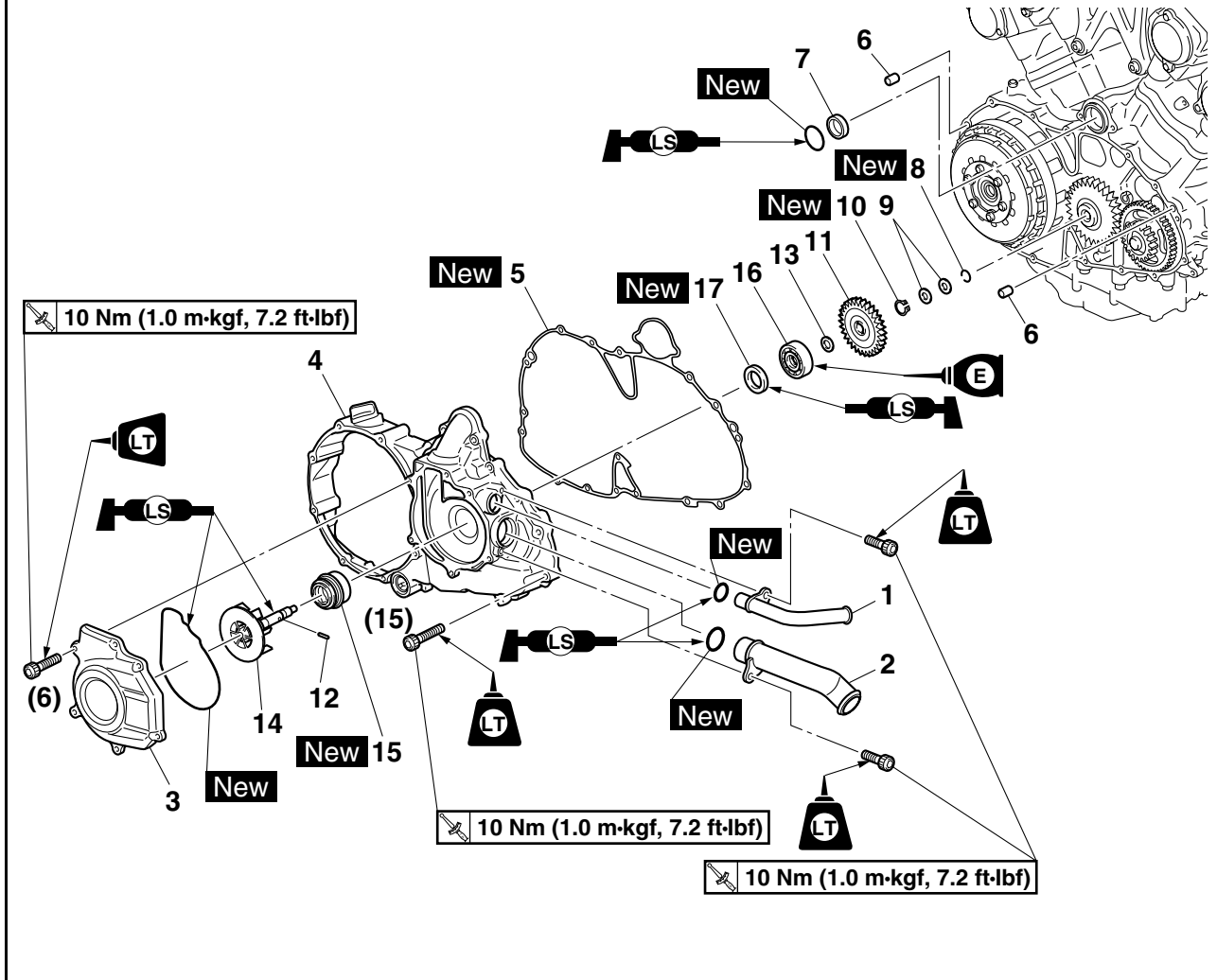

Order	Job/Parts to remove	Q'ty	Remarks
	Engine oil		Drain. Refer to "CHANGING THE ENGINE OIL" on page 3-11.
	Coolant		Drain. Refer to "CHANGING THE COOLANT" on page 3-19.
	Clutch cover		Refer to "CLUTCH" on page 5-48.
1	Water pump outlet pipe	1	
2	Water pump inlet pipe	1	
3	Water pump cover	1	
4	Crankcase cover	1	
5	Gasket	1	
6	Dowel pin	2	
7	Crankcase cover sleeve	1	
8	Circlip	1	
9	Washer	2	
10	Circlip	1	

WATER PUMP

Removing the water pump

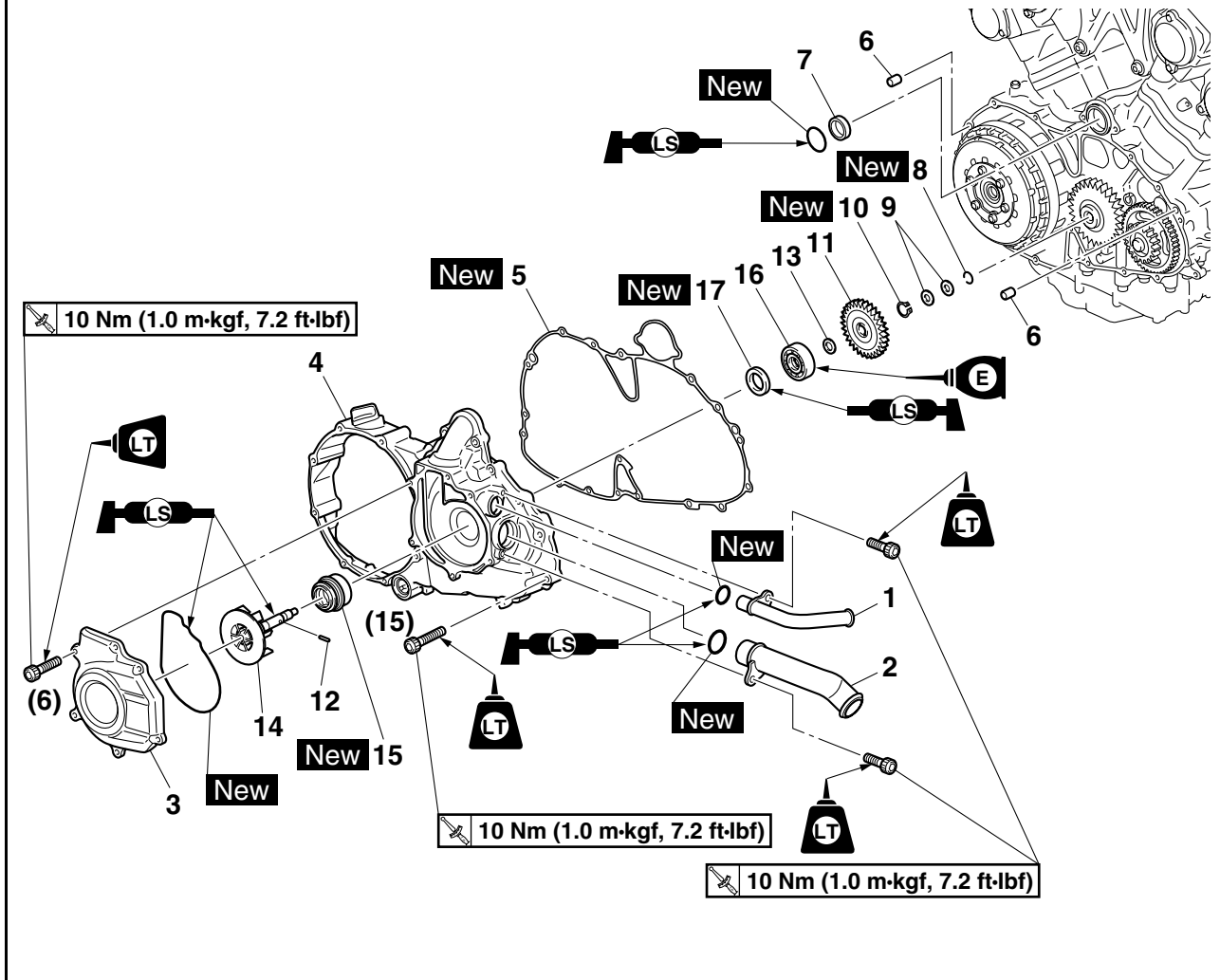

Order	Job/Parts to remove	Q'ty	Remarks
11	Water pump driven gear	1	
12	Gear stopper pin	1	
13	Washer	1	
14	Impeller shaft	1	
15	Water pump seal	1	
16	Bearing	1	
17	Oil seal	1	
			For installation, reverse the removal procedure.

EAS26510

DISASSEMBLING THE WATER PUMP

1. Remove:

- Water pump seal “1”

TIP

Remove the water pump seal from the inside of the crankcase cover “2”.

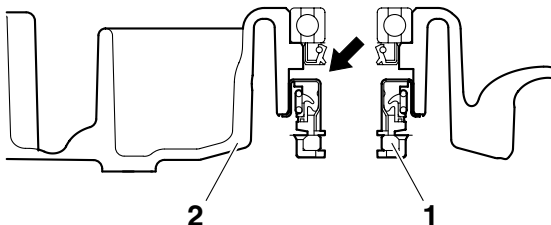

2. Remove:

- Bearing “1”
- Oil seal “2”

TIP

Remove the bearing and oil seal from the outside of the crankcase cover “3”.

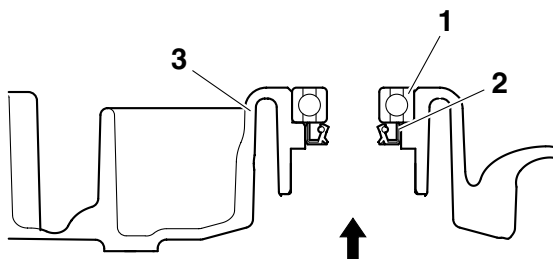

EAS26540

CHECKING THE WATER PUMP

1. Check:

- Water pump cover
- Impeller shaft
- Water pump seal
- Oil seal

Cracks/damage/wear → Replace.

2. Check:

- Bearing

Rough movement → Replace.

3. Check:

- Water pump outlet pipe
- Water pump inlet pipe

Cracks/damage/wear → Replace.

EAS26570

ASSEMBLING THE WATER PUMP

1. Install:

- Oil seal “1” **New**
(into the crankcase cover)



Installed depth “a”
0 mm (0 in)

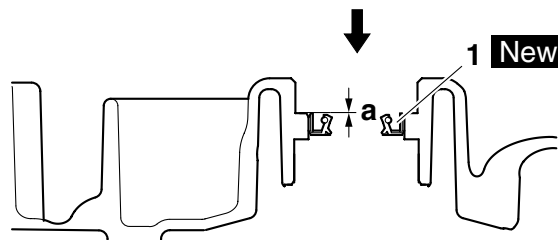

2. Install:

- Water pump seal “1” **New**
(into the crankcase cover “2”)

ECA14080

NOTICE

Never lubricate the water pump seal surface with oil or grease.

TIP

- Apply coolant to the lip of the water pump seal.
- Install the water pump seal with the special tools.

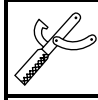

Mechanical seal installer
90890-04132
Water pump seal installer
YM-33221-A
Middle driven shaft bearing driver
90890-04058
Bearing driver 40 mm
YM-04058

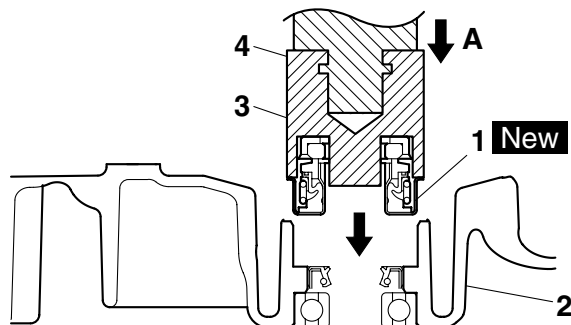

3. Mechanical seal installer

4. Middle driven shaft bearing driver

A. Push down

3. Install:

- Impeller “1”
- Washer
- Water pump driven gear
- Circlip **New**

TIP _____

After installation, check that the impeller shaft rotates smoothly.

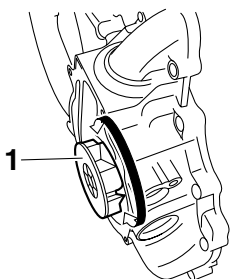

EAS26590

INSTALLING THE WATER PUMP

1. Fill:

- Cooling system
(with the specified amount of the recommended coolant)
Refer to “CHANGING THE COOLANT” on page 3-19.

2. Check:

- Cooling system
Leaks → Repair or replace the faulty part.

3. Measure:

- Radiator cap opening pressure
Below the specified pressure → Replace the radiator cap.
Refer to “CHECKING THE RADIATORS” on page 6-4.

FUEL SYSTEM

FUEL TANK	7-1
REMOVING THE FUEL TANK.....	7-3
REMOVING THE FUEL PUMP.....	7-3
CHECKING THE FUEL PUMP BODY.....	7-3
CHECKING THE ROLLOVER VALVE.....	7-3
INSTALLING THE FUEL PUMP.....	7-3
INSTALLING THE FILLER NECK.....	7-4
INSTALLING THE FUEL TANK.....	7-4
CHECKING THE FUEL PRESSURE.....	7-4
AIR FILTER CASE	7-6
CHECKING THE INTAKE FUNNELS.....	7-8
REMOVING THE AIR FILTER CASE AND INTAKE FUNNELS.....	7-8
INSTALLING THE AIR FILTER CASE AND INTAKE FUNNELS.....	7-9
THROTTLE BODIES	7-11
CHECKING THE INJECTORS.....	7-14
INSTALLING THE INJECTORS.....	7-14
CHECKING THE INJECTOR PRESSURE.....	7-14
CHECKING AND CLEANING THE THROTTLE BODIES.....	7-15
ADJUSTING THE THROTTLE POSITION SENSOR.....	7-16
ADJUSTING THE ACCELERATOR POSITION SENSOR.....	7-17
AIR INDUCTION SYSTEM	7-19
CHECKING THE AIR INDUCTION SYSTEM.....	7-23

EAS26620

FUEL TANK

Removing the fuel tank

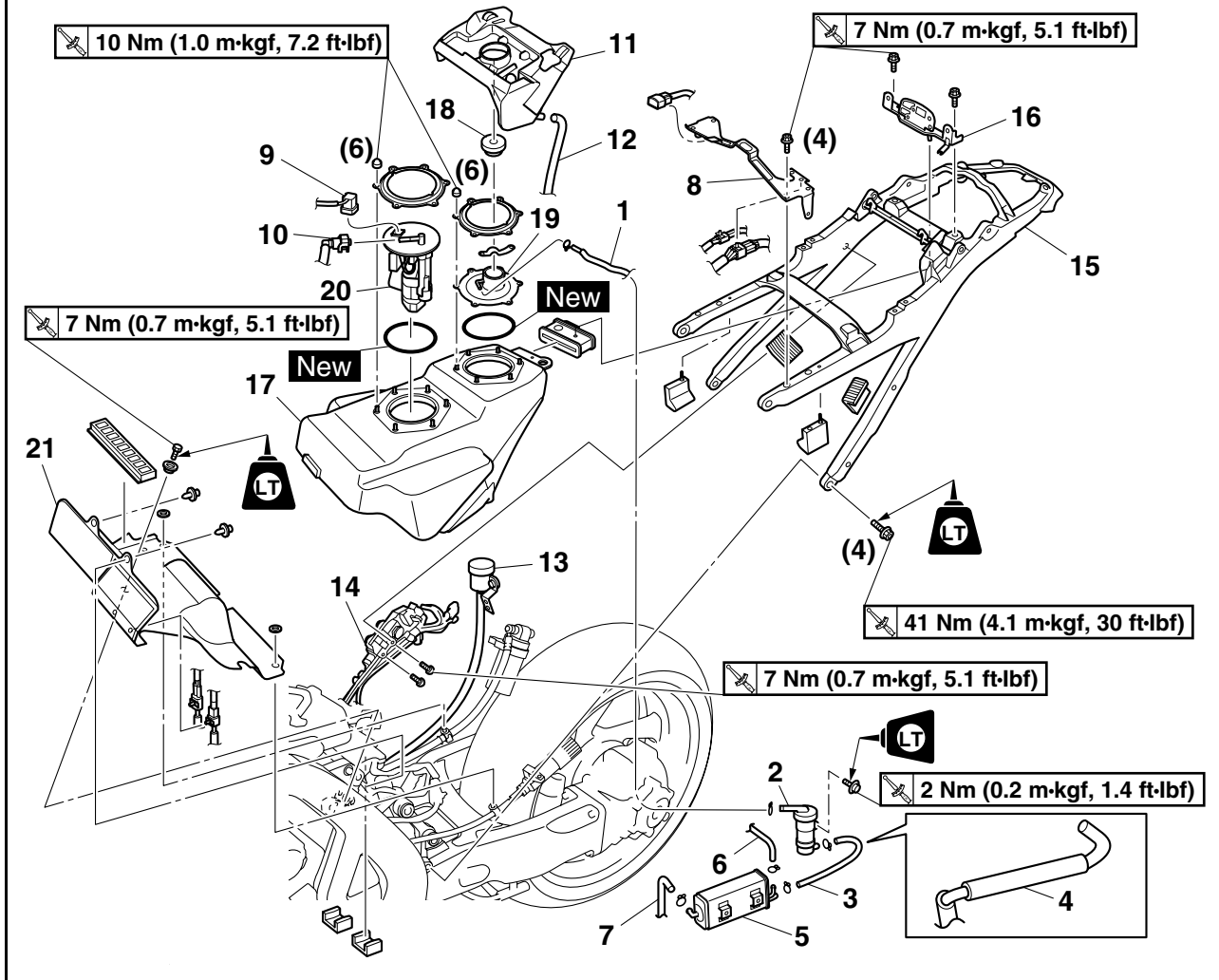

Order	Job/Parts to remove	Q'ty	Remarks
	Mudguard 2		Refer to "GENERAL CHASSIS" on page 4-1.
1	Fuel tank breather hose (fuel tank to rollover valve)	1	
2	Rollover valve	1	
3	Fuel tank breather hose (rollover valve to canister)	1	For California only
4	Fuel tank breather hose	1	Except for California
5	Canister	1	For California only
6	Canister purge hose	1	Disconnect. For California only
7	Canister breather hose	1	For California only
8	Rider seat bracket	1	
9	Fuel pump coupler	1	Disconnect.
10	Fuel hose	1	Disconnect.
11	Filler cover	1	
12	Fuel overflow hose	1	

Removing the fuel tank

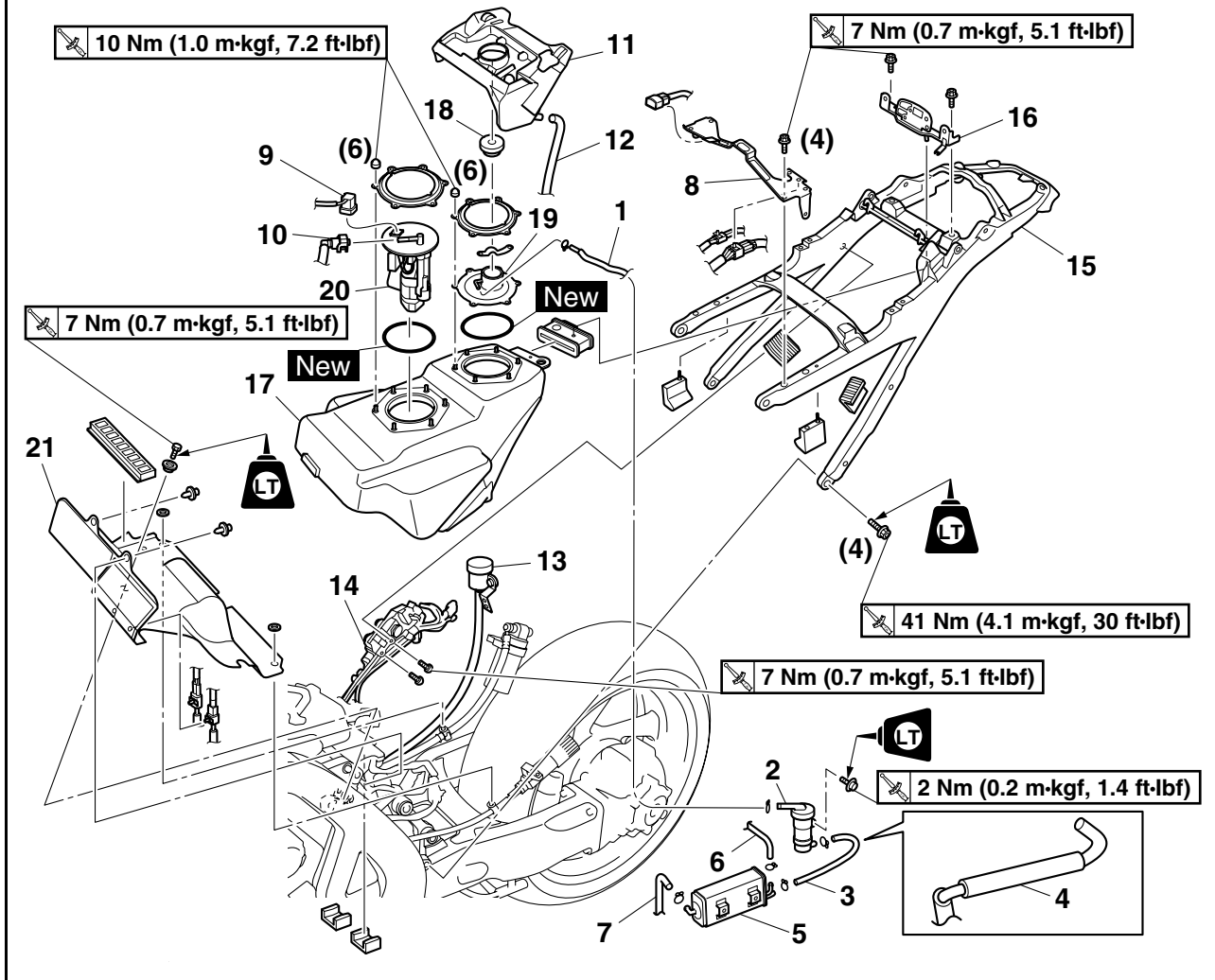

Order	Job/Parts to remove	Q'ty	Remarks
13	Brake fluid reservoir	1	
14	EXUP servo motor assembly	1	
15	Rear frame	1	
16	Fuel tank bracket	1	
17	Fuel tank	1	
18	Fuel tank cap	1	
19	Filler neck	1	
20	Fuel pump	1	
21	Fuel tank protector	1	
			For installation, reverse the removal procedure.

EAS26630

REMOVING THE FUEL TANK

1. Extract the fuel in the fuel tank through the fuel tank cap with a pump.
2. Disconnect:
 - Fuel pump coupler
 - Fuel hose

EWA2S31026

WARNING

Cover fuel hose connections with a cloth when disconnecting them. Residual pressure in the fuel lines could cause fuel to spurt out when removing the hoses.

ECA14700

NOTICE

Although the fuel has been removed from the fuel tank be careful when removing the fuel hoses, since there may be fuel remaining in it.

TIP

- To remove the fuel hose from the fuel pump, slide the fuel hose connector cover “1” on the end of the hose in the direction of the arrow shown, press the two buttons “2” on the sides of the connector, and then remove the hose.
- Remove the fuel hose manually without using any tools.
- Before removing the hose, place a few rags in the area under where it will be removed.

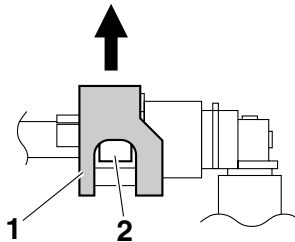

3. Remove:
 - Rear frame (with fuel tank)

TIP

Leave the fuel tank mounted in the rear frame when removing the rear frame.

EAS26640

REMOVING THE FUEL PUMP

1. Remove:
 - Fuel pump

ECA14720

NOTICE

- Do not drop the fuel pump or give it a strong shock.
- Do not touch the base section of the fuel sender.

EAS26670

CHECKING THE FUEL PUMP BODY

1. Check:
 - Fuel pump body
 - Obstruction → Clean.
 - Cracks/damage → Replace fuel pump assembly.

EAS2S31082

CHECKING THE ROLLOVER VALVE

1. Check:
 - Rollover valve
 - Damage/faulty → Replace.

TIP

- Check that air flows smoothly only in the direction of the arrow shown in the illustration.
- The rollover valves must be in an upright position when checking the airflow.

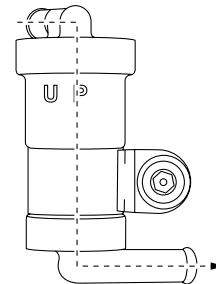

EAS26700

INSTALLING THE FUEL PUMP

1. Install:
 - Fuel pump gasket **New**
 - Fuel pump
 - Fuel pump bracket



Fuel pump nut
10 Nm (1.0 m·kgf, 7.2 ft·lbf)

TIP

- Do not damage the installation surfaces of the fuel tank when installing the fuel pump.
- Always use a new fuel pump gasket.
- Install the fuel pump in the direction shown in the illustration.
- Align the projections “a” on the fuel pump with the slots in the fuel pump bracket.

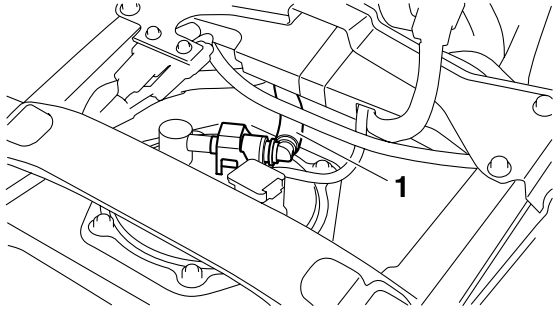

- c. Connect the pressure gauge "2" and adapter "3" to the fuel hose "1".

	Pressure gauge 90890-03153 YU-03153
	Fuel pressure adapter 90890-03176 YM-03176

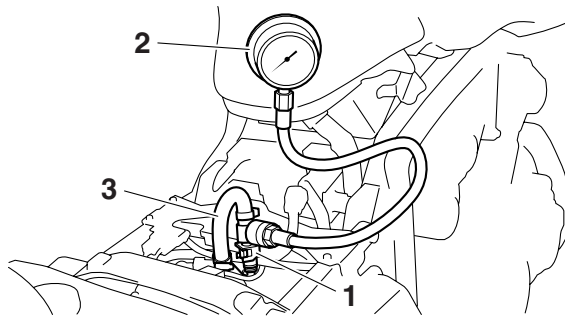

- d. Start the engine.
e. Measure the fuel pressure.

	Fuel line pressure 324.0 kPa (3.24 kgf/cm ² , 47.0 psi)
---	---

Faulty → Replace the fuel pump.



EAS2S31001

AIR FILTER CASE

Removing the air filter case and intake funnels

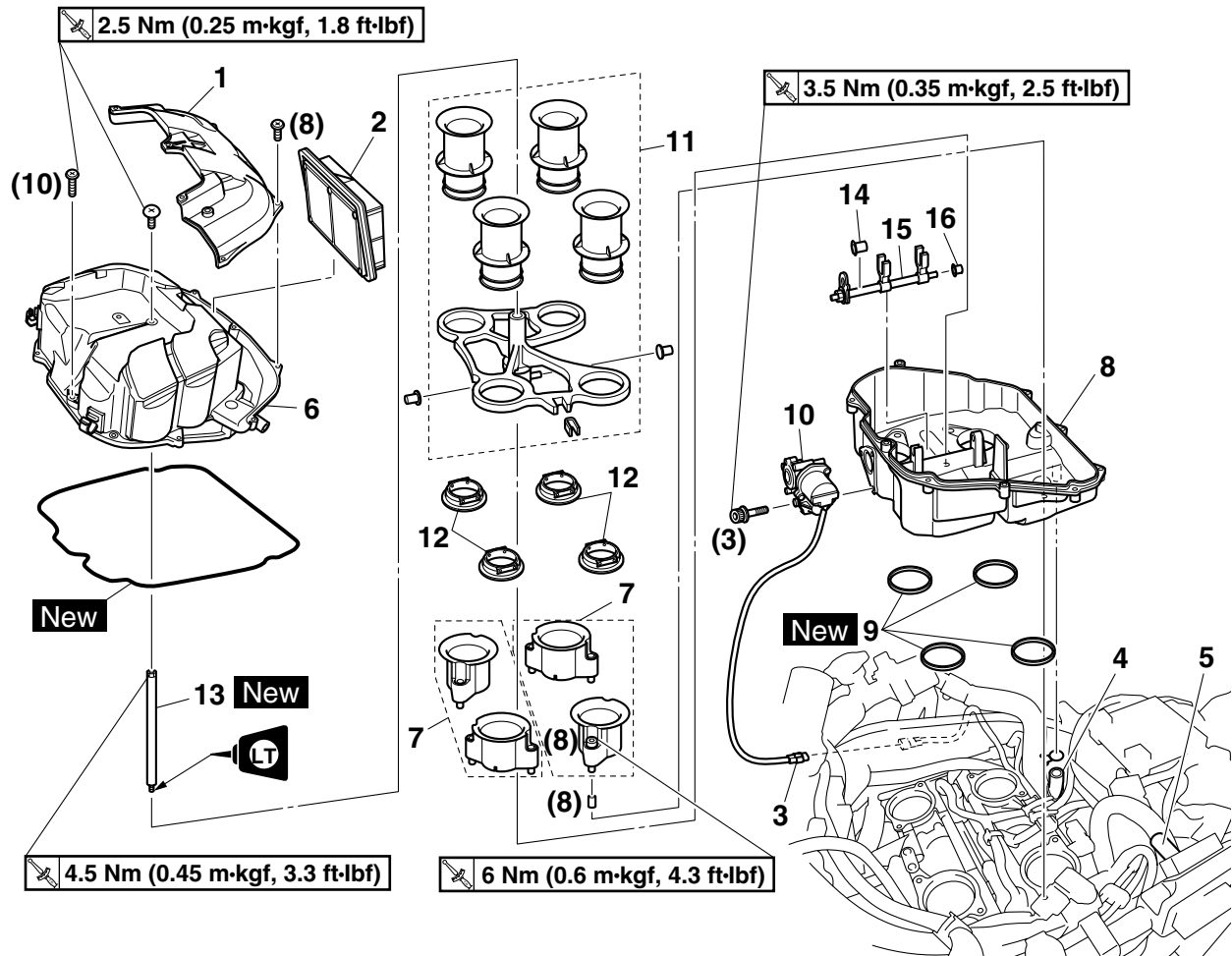

Order	Job/Parts to remove	Q'ty	Remarks
	Intake duct assemblies/Battery box		Refer to "GENERAL CHASSIS" on page 4-1.
1	Air filter case cover	1	
2	Air filter element	1	
3	Intake funnel servo motor coupler	1	Disconnect.
4	Crankcase breather hose	1	Disconnect.
5	Air induction system hose (air filter case to air chamber)	1	Disconnect.
6	Upper air filter case	1	
7	Fixed intake funnel	4	
8	Lower air filter case	1	
9	Lower air filter case gasket	4	
10	Intake funnel servo motor	1	
11	Variable intake funnel assembly	1	
12	Variable intake funnel seal	4	
13	Variable intake funnel holder shaft	1	
14	Bushing 1	1	

AIR FILTER CASE

Removing the air filter case and intake funnels

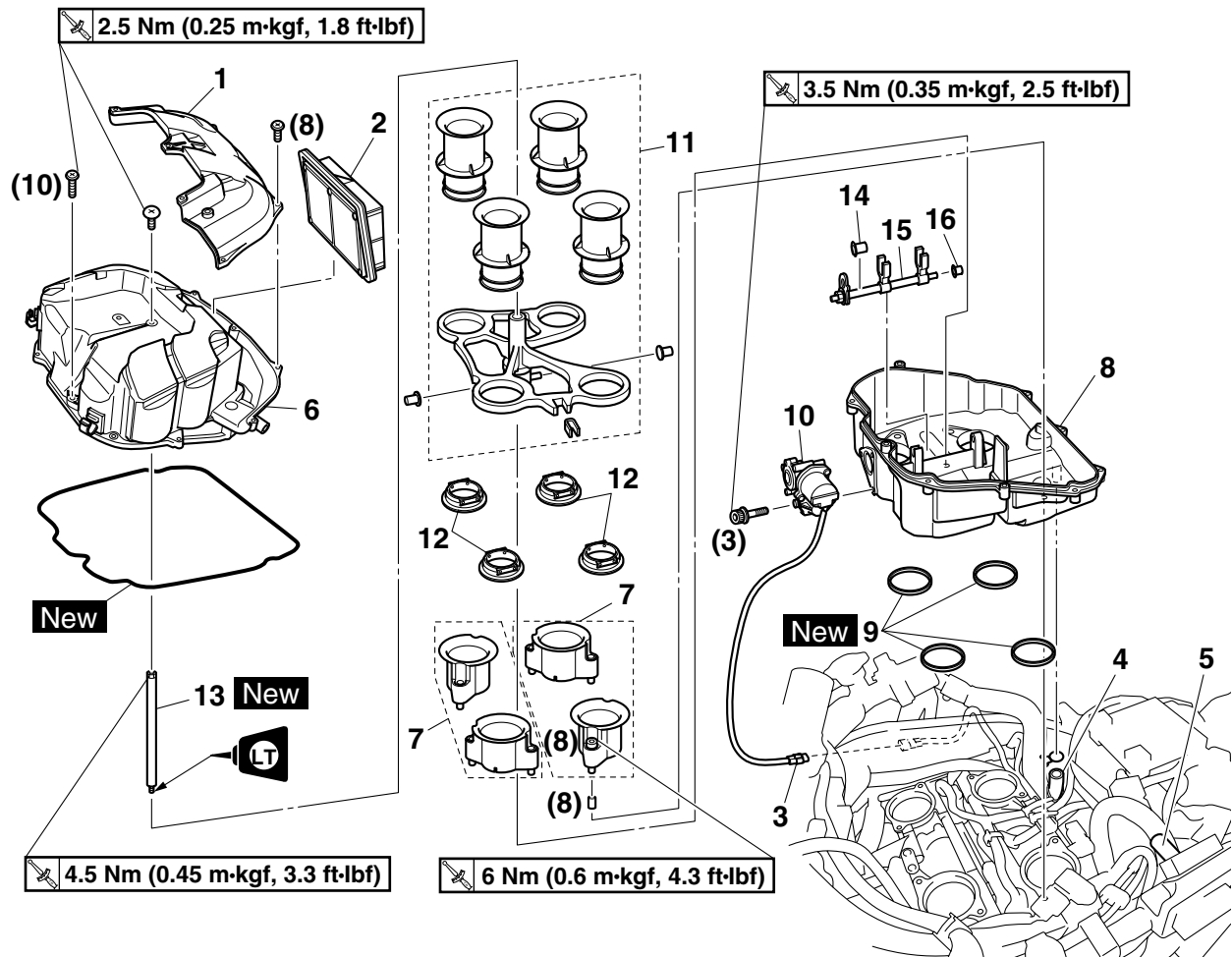

Order	Job/Parts to remove	Q'ty	Remarks
15	Variable intake funnel lever shaft	1	
16	Bushing 2	1	
			For installation, reverse the removal procedure.

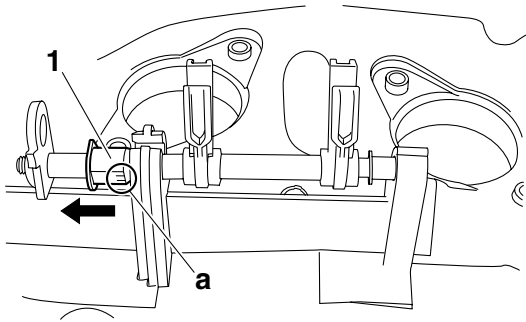

EAS2S31007

INSTALLING THE AIR FILTER CASE AND INTAKE FUNNELS

1. Install:

- Variable intake funnel lever shaft

TIP

- To install the variable intake funnel lever shaft into the lower air filter case, slide the bushing 1 "1" in the direction of the arrow.
- Face the cutout "a" in bushing 1 "1" downward.

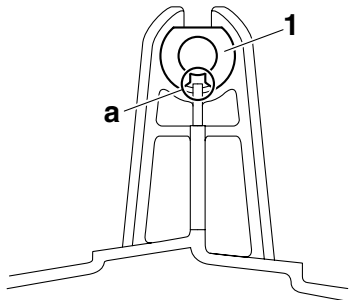
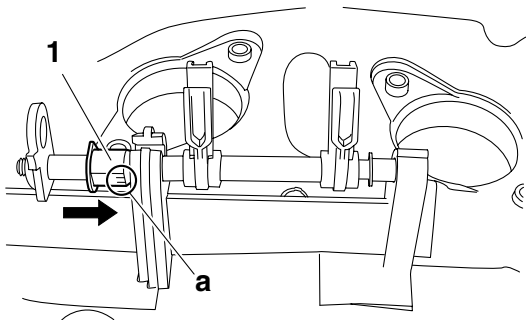

2. Install:

- Variable intake funnels "1"
- Variable intake funnel seals "2"

TIP

Be careful not to break the pin "a" on each variable intake funnel seal "1" when installing the seals.

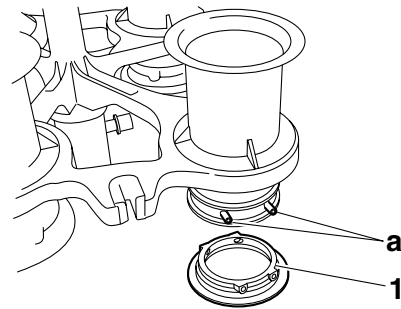

3. Install:

- Lower air filter case gaskets "1" **New**

TIP

Make sure that the lower air filter case gaskets "1" are seated in the lower air filter case grooves.

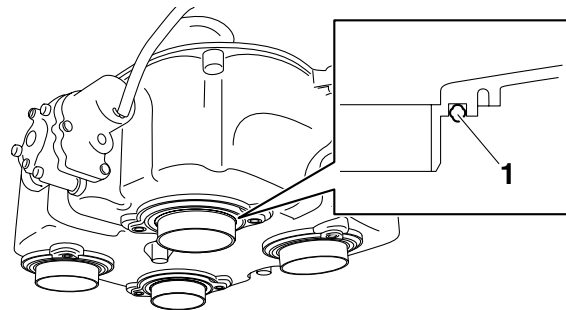

4. Check:

- Variable intake funnel movement

- Connect the intake funnel servo motor coupler when installing the intake funnel servo motor into the lower air filter case.
- Set the main switch to the "ON" position. The variable intake funnels "1" move into the down position. Make sure that the lip of the variable intake funnel seals "2" are seated in the fixed intake funnels "3". (illustration A)
- Set the main switch to the "OFF" position. The variable intake funnels "1" move into the center position. (illustration B)

A

B

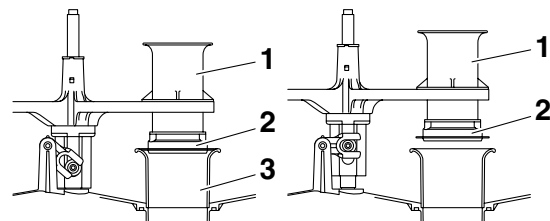

A. Down

B. Center

5. Install:
- Upper air filter case



Upper air filter case screw
2.5 Nm (0.25 m·kgf, 1.8 ft·lbf)

TIP

Tighten the upper air filter case screws in proper sequence as shown.

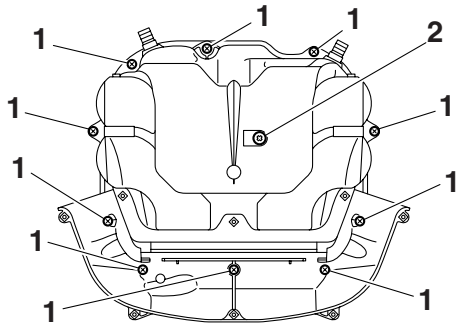

EAS26970

THROTTLE BODIES

Removing the throttle bodies

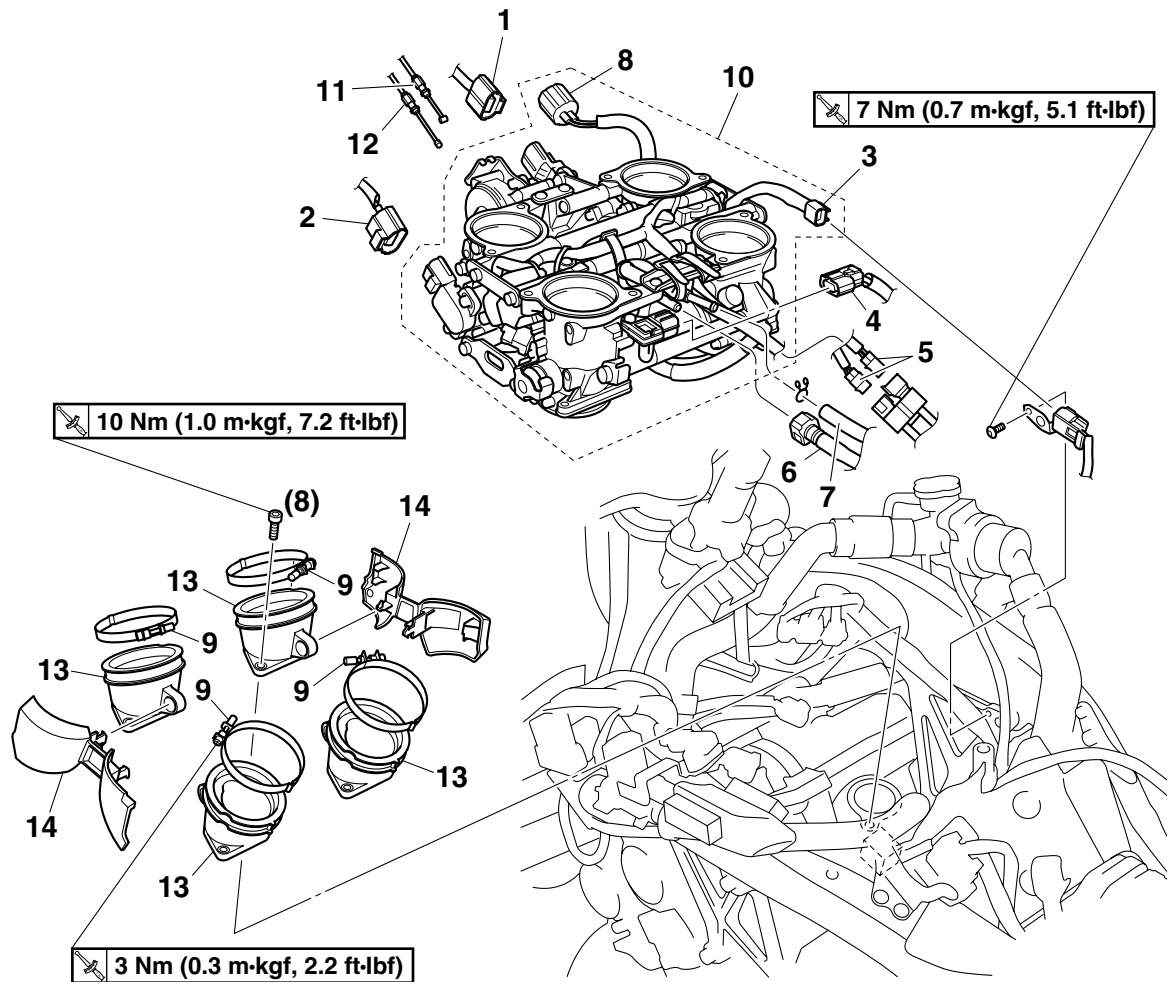

Order	Job/Parts to remove	Q'ty	Remarks
	Lower air filter case		Refer to "AIR FILTER CASE" on page 7-6.
1	Accelerator position sensor coupler	1	Disconnect.
2	Throttle position sensor coupler	1	Disconnect.
3	Throttle servo motor coupler	1	Disconnect.
4	Intake air pressure sensor coupler	1	Disconnect.
5	Sub-wire harness coupler	2	Disconnect.
6	Fuel hose	1	Disconnect.
7	Canister purge hose	1	Disconnect. For California only
8	Coolant temperature sensor coupler	1	Disconnect.
9	Throttle body joint clamp screw	4	Loosen.
10	Throttle bodies	1	
11	Throttle cable (decelerator cable)	1	Silver adjusting bolt
12	Throttle cable (accelerator cable)	1	Black adjusting bolt
13	Throttle body joint	4	

THROTTLE BODIES

Removing the throttle bodies

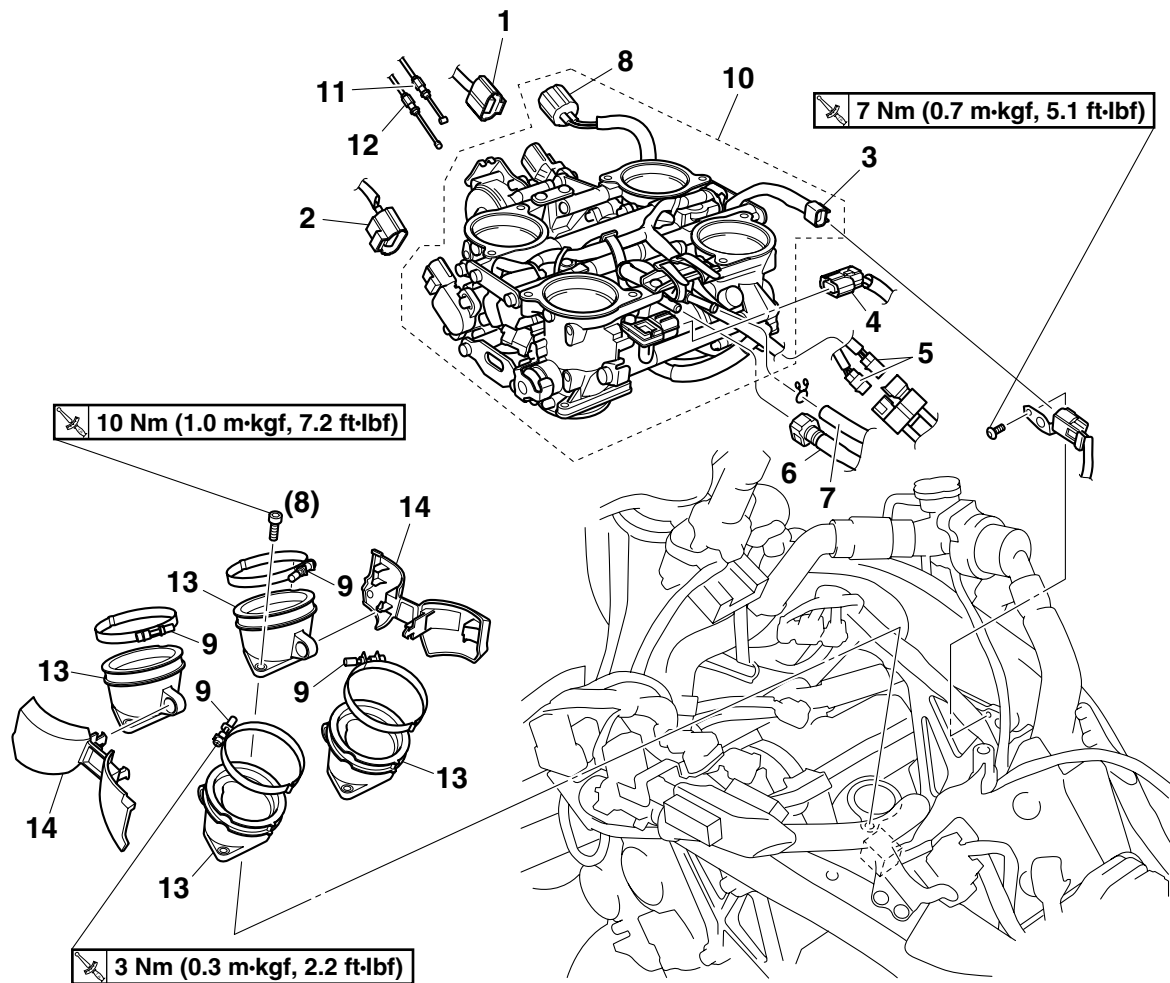

Order	Job/Parts to remove	Q'ty	Remarks
14	Throttle body joint cover	2	
			For installation, reverse the removal procedure.

THROTTLE BODIES

Removing the injectors

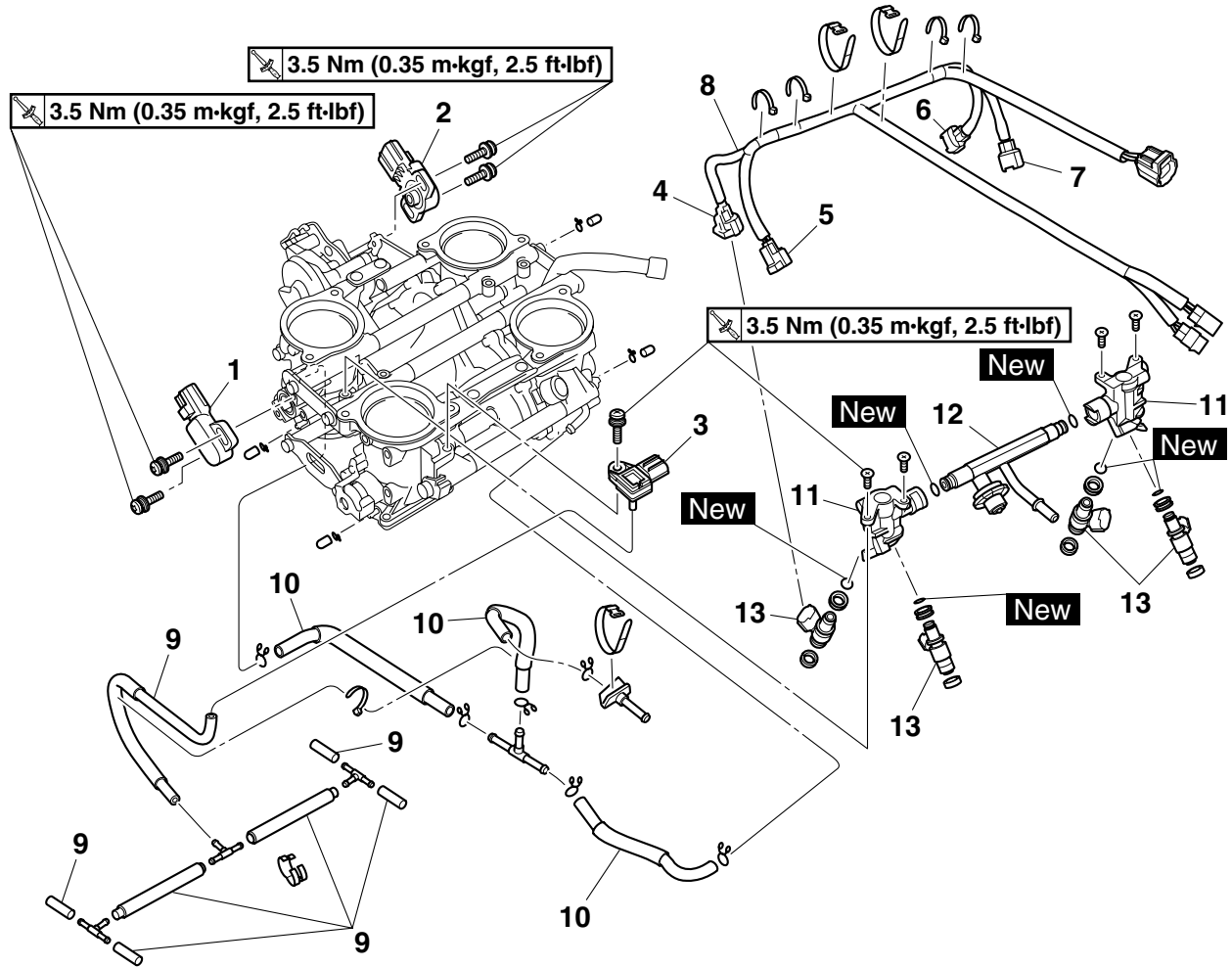

Order	Job/Parts to remove	Q'ty	Remarks
1	Throttle position sensor	1	
2	Accelerator position sensor	1	
3	Intake air pressure sensor	1	
4	Cylinder-#2 injector coupler	1	Disconnect.
5	Cylinder-#1 injector coupler	1	Disconnect.
6	Cylinder-#4 injector coupler	1	Disconnect.
7	Cylinder-#3 injector coupler	1	Disconnect.
8	Sub-wire harness	1	
9	Negative pressure hose	7	
10	Canister purge hose	3	For California only
11	Injector joint	2	
12	Fuel rail	1	
13	Injector	4	
			For installation, reverse the removal procedure.

Pressure drops → Properly install or replace the injector



EAS2S31095

CHECKING AND CLEANING THE THROTTLE BODIES

TIP

Clean the throttle bodies only if they cannot be synchronized using the bypass air screws. Before cleaning the throttle bodies, check the following items:

- Valve clearance
- Spark plugs
- Air filter element
- Throttle body joints
- Fuel hoses
- Air induction system
- Exhaust system
- Canister purge hoses (for California only)
- Breather hoses

EWA2S31033

WARNING

- If the throttle bodies are subjected to strong shocks or dropped during cleaning, replace them as a set.
- Before removing the throttle bodies to clean them, check the operation of the throttle bodies. Refer to “FUEL INJECTION SYSTEM” on page 8-33.

1. Check:

- Throttle bodies
- Cracks/damage → Replace the throttle bodies as a set.

TIP

If the protector “a” is scratched or damaged, replace the throttle bodies as a set.

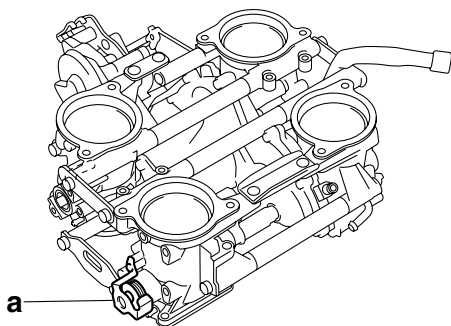

2. Clean:

- Throttle bodies

ECA2S31068

NOTICE

- Observe the following precautions; otherwise, the throttle bodies may not operate properly.
- Do not open the throttle valves quickly.
- Do not subject the throttle bodies to excessive force.
- Wash the throttle bodies in a petroleum-based solvent.
- Do not use any caustic carburetor cleaning solution.
- Do not apply cleaning solvent directly to any plastic parts, sensors, or seals.
- Do not directly push the throttle valves to open them.
- Do not touch the portion “a” of the throttle valve shaft; otherwise, the throttle body synchronization will be affected.

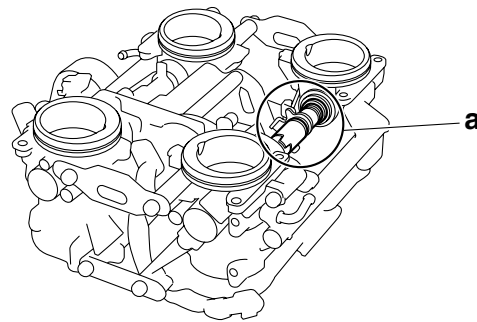

- a. Place the throttle bodies on a flat surface with the engine side facing up.
- b. Install the caps (18P-2464V-00) onto the hose fittings “a” and canister purge hose fittings (for California only) “b”.

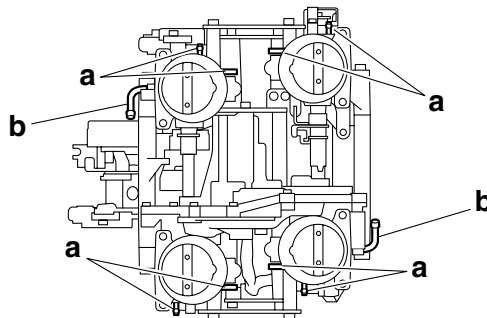

- c. Fit a suitable pipe “1” (D = 11 mm, d = 9 mm, and L = 140 mm or more) onto the projection “a” on the throttle valve shaft, rotate the shaft in the direction shown in the illustration to hold the throttle valves in the open position.

EWA2S31034

WARNING

When cleaning the throttle bodies, be careful not to injure yourself on the throttle valves or other components of the throttle bodies.

ECA2S31074

NOTICE

Do not open the throttle valves by supplying electrical power to the throttle bodies.

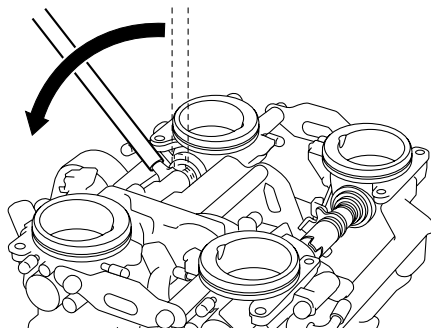
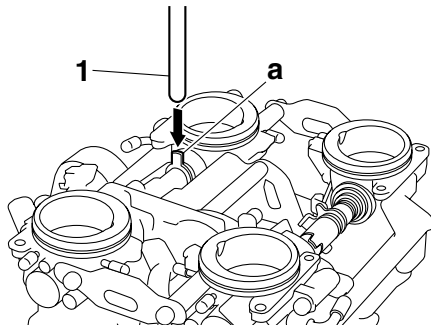

d. Apply a petroleum-based solvent to the throttle valves and the inside of the throttle bodies to remove any carbon deposits.

TIP

- Do not allow any petroleum-based solvent to enter the opening for the injectors.
- Do not apply any petroleum-based solvent to the portions of the throttle valve shafts between the throttle bodies.

e. Remove the carbon deposits from the inside of each throttle body in a downward direction, from the engine side of the throttle body to the air filter case side.

ECA2S31069

NOTICE

- Do not use a tool, such as a wire brush, to remove the carbon deposits; otherwise, the inside of the throttle bodies may be damaged.

- Do not allow carbon deposits or other foreign materials to enter any of the passages in each throttle body or in the space between the throttle valve shaft and the throttle body.

- After removing the carbon deposits, clean the inside of the throttle bodies with a petroleum-based solvent, and then dry the throttle bodies using compressed air.
- Make sure that there are no carbon deposits or other foreign materials in any of the passages “a” in each throttle body or in the space “b” between the throttle valve shaft and the throttle body.

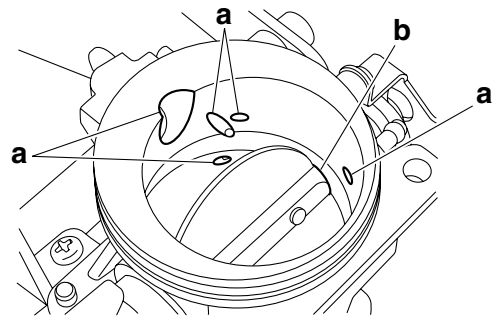

- Check:
 - Fuel passages
Obstructions → Clean.



- Wash the throttle bodies in a petroleum-based solvent.

ECA2S31070

NOTICE

Do not use any caustic carburetor cleaning solution.

- Blow out all of the passages with compressed air.



EAS29080

ADJUSTING THE THROTTLE POSITION SENSOR

EWA2S31016

WARNING

- Handle the throttle position sensor with special care.
- Never subject the throttle position sensor to strong shocks. If the throttle position sensor is dropped, replace it.

- Check:
 - Throttle position sensor
Refer to “CHECKING THE THROTTLE POSITION SENSOR” on page 8-137.

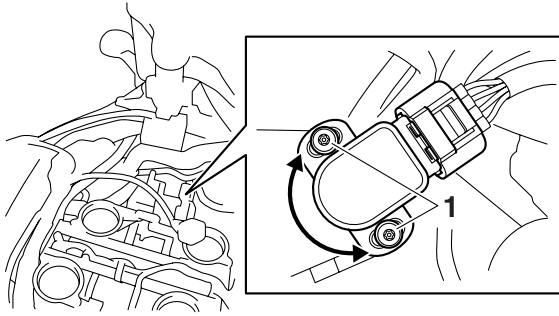

EAS27040

AIR INDUCTION SYSTEM

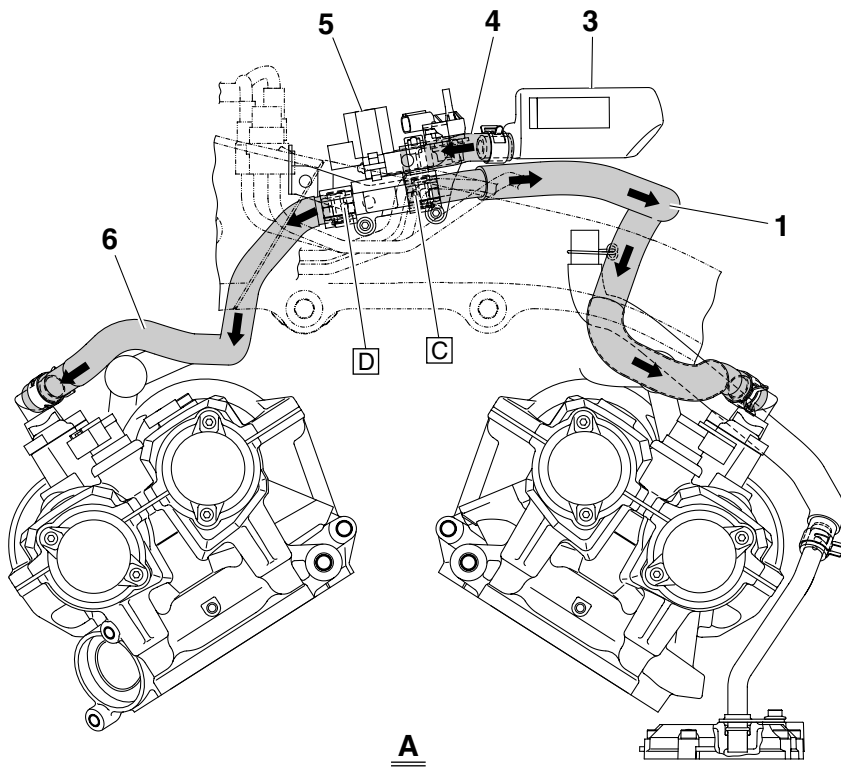
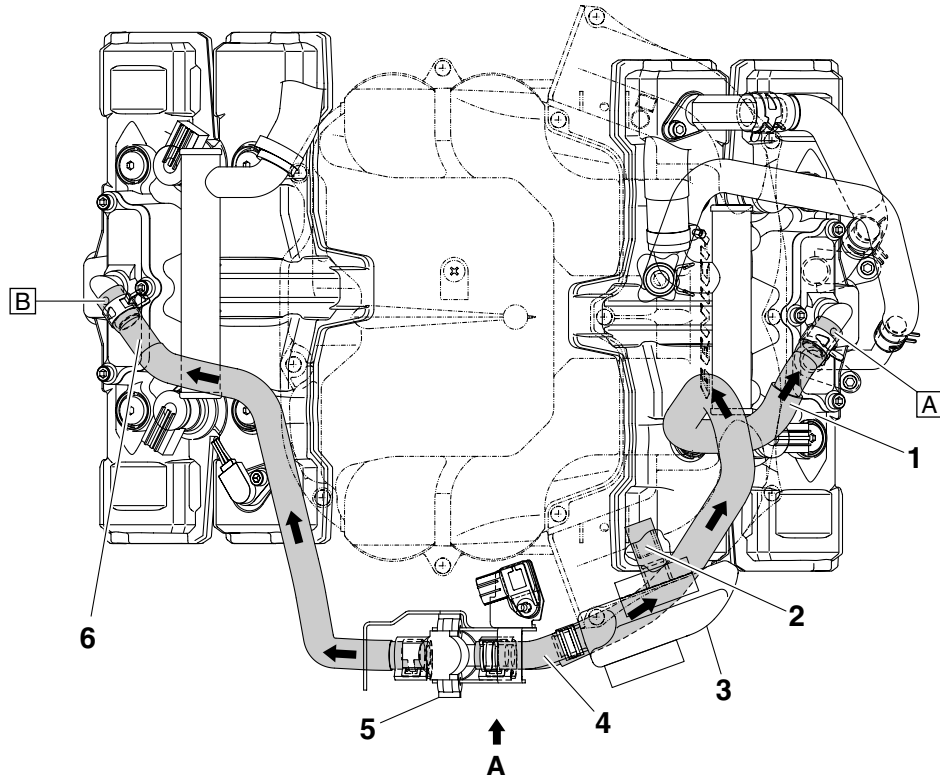

1. Air induction system hose (air cut-off valve to rear reed valve cover)
 2. Air induction system hose (air filter case to air chamber)
 3. Air chamber
 4. Air induction system hose (air chamber to air cut-off valve)
 5. Air cut-off valve
 6. Air induction system hose (air cut-off valve to front reed valve cover)
- A. Install the air induction system hose (air cut-off valve to rear reed valve cover) with its paint mark facing upward.
 - B. Install the air induction system hose (air cut-off valve to front reed valve cover) with its paint mark facing upward.
 - C. Install the air induction system hose (air cut-off valve to rear reed valve cover) with its paint mark facing outward.
 - D. Install the air induction system hose (air cut-off valve to front reed valve cover) with its paint mark facing outward.

AIR INDUCTION SYSTEM

Removing the air cut-off valve assembly and hoses

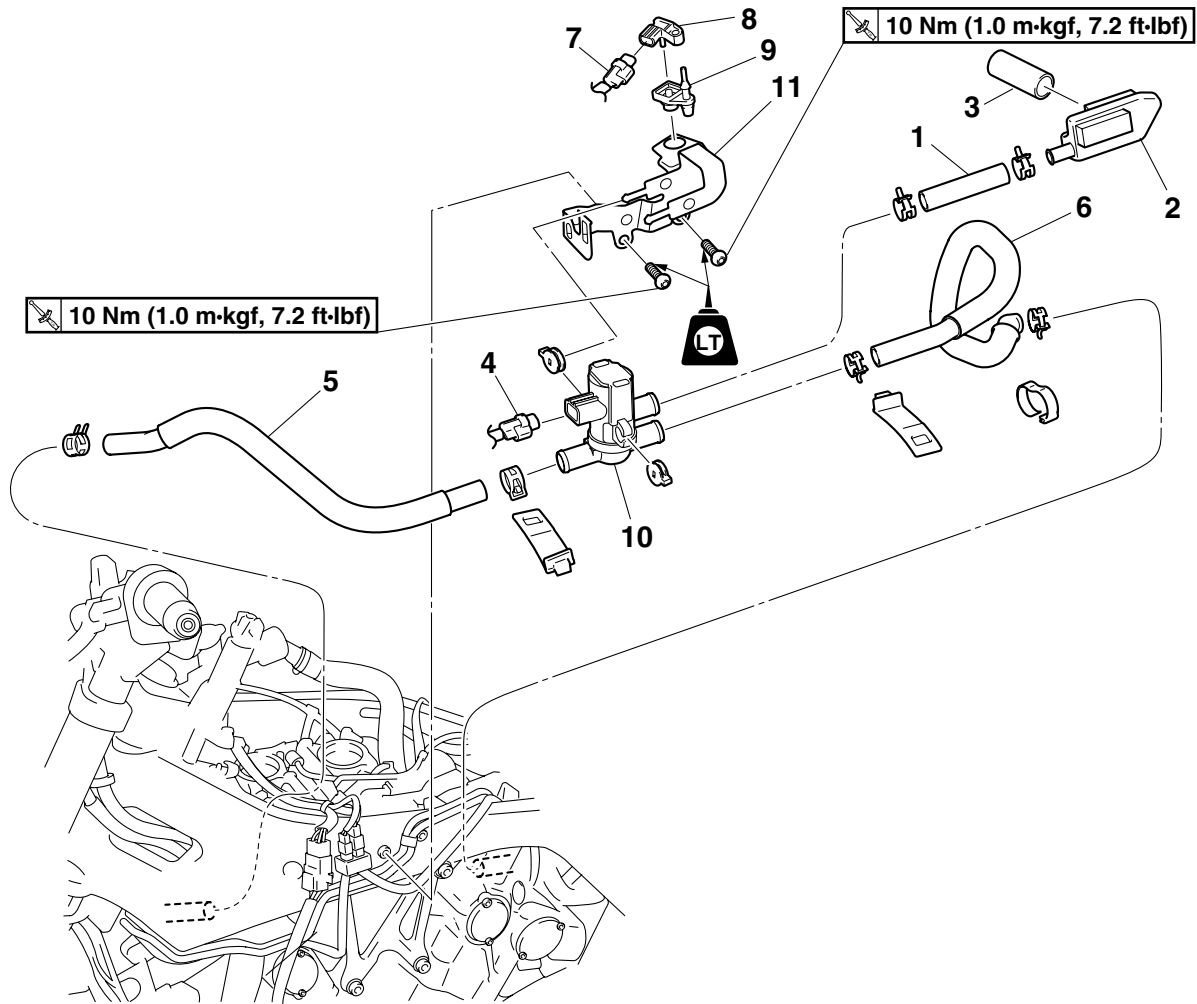

Order	Job/Parts to remove	Q'ty	Remarks
	Lower air filter case		Refer to "AIR FILTER CASE" on page 7-6.
1	Air induction system hose (air filter case to air chamber)	1	
2	Air chamber	1	
3	Air induction system hose (air filter case to air chamber)	1	
4	Air induction system solenoid coupler	1	Disconnect.
5	Air induction system hose (air cut-off valve to front reed valve cover)	1	
6	Air induction system hose (air cut-off valve to rear reed valve cover)	1	
7	Atmospheric pressure sensor coupler	1	Disconnect.
8	Atmospheric pressure sensor	1	
9	Grommet	1	
10	Air cut-off valve	1	
11	Air cut-off valve bracket	1	
			For installation, reverse the removal procedure.

Removing the reed valves

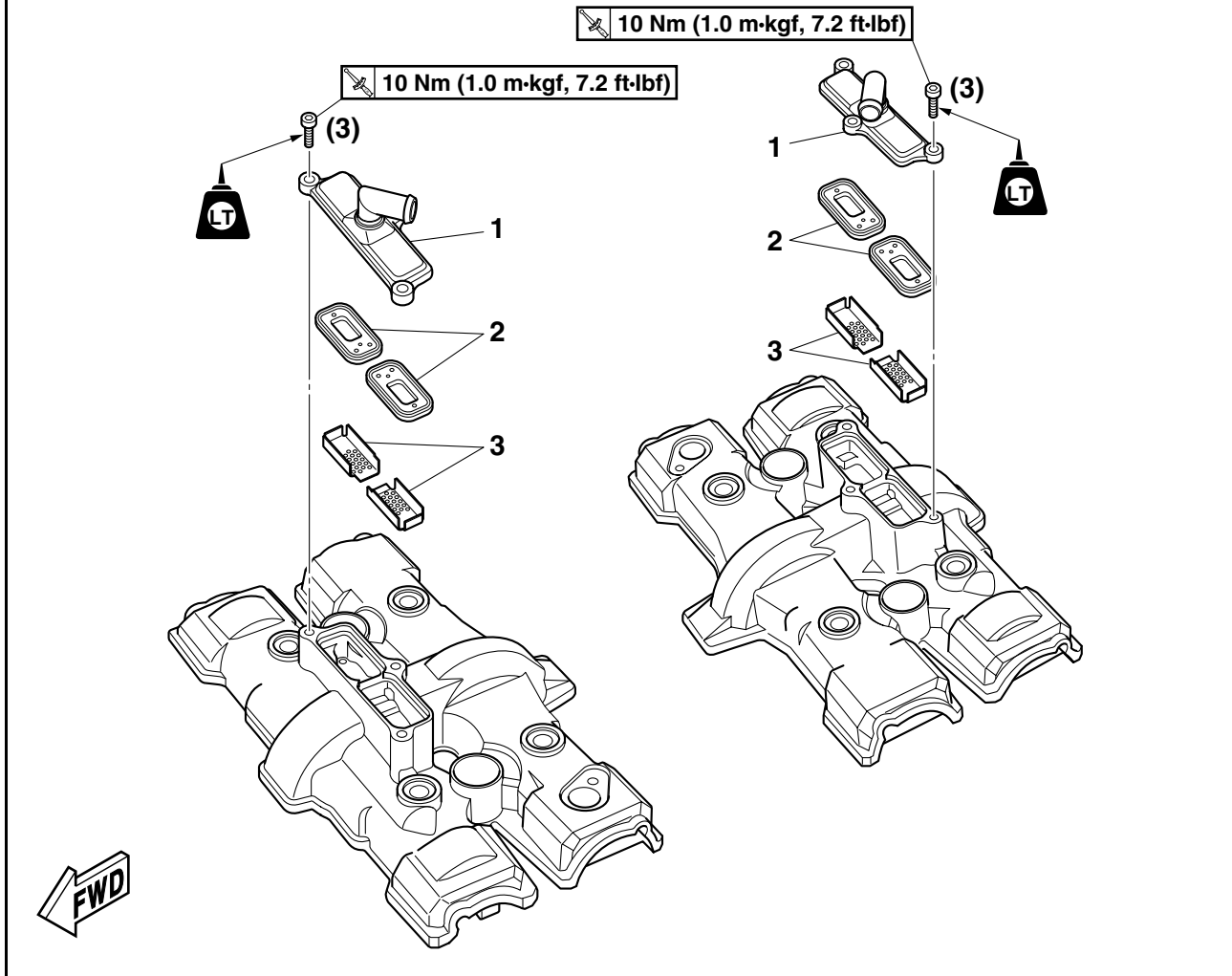

Order	Job/Parts to remove	Q'ty	Remarks
	Cylinder head covers		Refer to "CAMSHAFTS" on page 5-9.
1	Reed valve cover	2	
2	Reed valve assembly	4	
3	Reed valve plate	4	
			For installation, reverse the removal procedure.

EAS27060

CHECKING THE AIR INDUCTION SYSTEM

Air induction

The air induction system burns unburned exhaust gases by injecting fresh air (secondary air) into the exhaust port, reducing the emission of hydrocarbons. When there is negative pressure at the exhaust port, the reed valve opens, allowing secondary air to flow into the exhaust port. The required temperature for burning the unburned exhaust gases is approximately 600 to 700 °C (1112 to 1292 °F).

Air cut-off valve

The air cut-off valve is controlled by the signals from the ECU in accordance with the combustion conditions. Ordinarily, the air cut-off valve opens when the coolant temperature is below the specified value to allow the air to flow into the exhaust pipe assembly. When the engine is warm, the air cut-off valve opens while the vehicle is decelerating if the throttle grip is in the fully close position.

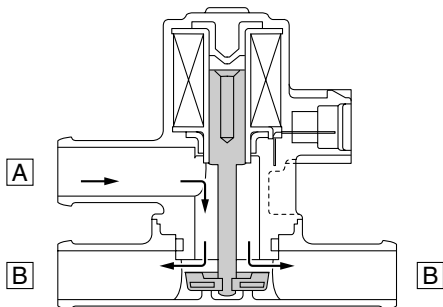
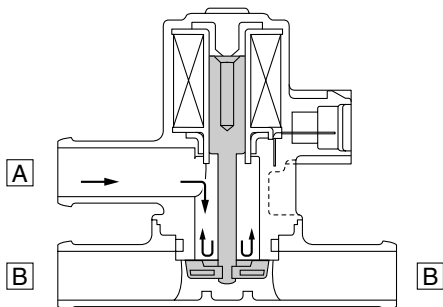

- A. From the air filter case
- B. To the cylinder head

1. Check:

- Hoses
Loose connections → Connect properly.
Cracks/damage → Replace.

2. Check:

- Reed valve

- Reed valve stopper
 - Reed valve seat
Cracks/damage → Replace the reed valve assembly.
3. Check:
- Air cut-off valve
Cracks/damage → Replace.
4. Check:
- Air induction system solenoid
Refer to “CHECKING THE AIR INDUCTION SYSTEM SOLENOID” on page 8-138.

ELECTRICAL SYSTEM

IGNITION SYSTEM	8-1
CIRCUIT DIAGRAM	8-1
ENGINE STOPPING DUE TO SIDESTAND OPERATION	8-3
TROUBLESHOOTING	8-4
ELECTRIC STARTING SYSTEM	8-7
CIRCUIT DIAGRAM	8-7
STARTING CIRCUIT CUT-OFF SYSTEM OPERATION	8-9
TROUBLESHOOTING	8-10
CHARGING SYSTEM	8-13
CIRCUIT DIAGRAM	8-13
TROUBLESHOOTING	8-15
LIGHTING SYSTEM	8-17
CIRCUIT DIAGRAM	8-17
TROUBLESHOOTING	8-19
SIGNALING SYSTEM	8-21
CIRCUIT DIAGRAM	8-21
TROUBLESHOOTING	8-23
COOLING SYSTEM	8-29
CIRCUIT DIAGRAM	8-29
TROUBLESHOOTING	8-31
FUEL INJECTION SYSTEM	8-33
CIRCUIT DIAGRAM	8-33
ECU SELF-DIAGNOSTIC FUNCTION	8-35
TROUBLESHOOTING METHOD	8-36
DIAGNOSTIC MODE	8-37
TROUBLESHOOTING DETAILS	8-43
FUEL PUMP SYSTEM	8-69
CIRCUIT DIAGRAM	8-69
TROUBLESHOOTING	8-71

ABS (ANTI-LOCK BRAKE SYSTEM)	8-73
CIRCUIT DIAGRAM	8-73
ABS COMPONENTS CHART	8-75
ABS COUPLER LOCATION CHART	8-77
MAINTENANCE OF THE ABS ECU	8-79
ABS TROUBLESHOOTING OUTLINE.....	8-79
BASIC INSTRUCTIONS FOR TROUBLESHOOTING	8-80
BASIC PROCESS FOR TROUBLESHOOTING	8-81
[A] CHECKING THE ABS WARNING LIGHT	8-82
[B-1] THE ABS WARNING LIGHT FAILS TO COME ON	8-82
[B-2] THE ABS WARNING LIGHT FLASHES	8-82
[B-3] THE ABS WARNING LIGHT REMAINS ON.....	8-82
[B-4] THE ABS WARNING LIGHT COMES ON FOR 2 SECONDS, THEN GOES OFF	8-82
[B-5] MALFUNCTION ARE CURRENTLY DETECTED	8-83
[C-1] ONLY THE ABS WARNING LIGHT FAILS TO COME ON	8-83
[C-2] ALL INDICATOR LIGHTS FAIL TO COME ON.....	8-83
[C-3] THE ABS WARNING LIGHT REMAINS ON.....	8-84
[C-4] THE ABS WARNING LIGHT FLASHES	8-84
[C-5] DIAGNOSIS USING THE FAULT CODES	8-85
[D-1] DELETING THE FAULT CODES	8-114
[D-2] DELETE FUNCTION TEST	8-114
[D-3] FINAL CHECK.....	8-115

ELECTRICAL COMPONENTS	8-117
CHECKING THE SWITCHES	8-121
CHECKING THE BULBS AND BULB SOCKETS	8-124
CHECKING THE FUSES	8-125
CHECKING AND CHARGING THE BATTERY	8-126
CHECKING THE RELAYS	8-129
CHECKING THE TURN SIGNAL/HAZARD RELAY.....	8-130
CHECKING THE RELAY UNIT (DIODE)	8-130
CHECKING THE IGNITION COILS.....	8-131
CHECKING THE IGNITION SPARK GAP.....	8-132
CHECKING THE CRANKSHAFT POSITION SENSOR.....	8-132
CHECKING THE LEAN ANGLE SENSOR.....	8-133
CHECKING THE STARTER MOTOR OPERATION	8-133
CHECKING THE STATOR COIL	8-134
CHECKING THE RECTIFIER/REGULATOR	8-134
CHECKING THE HORN.....	8-134
CHECKING THE OIL LEVEL SWITCH	8-135
CHECKING THE FUEL SENDER	8-135
CHECKING THE FUEL LEVEL WARNING LIGHT	8-136
CHECKING THE OIL LEVEL WARNING LIGHT	8-136
CHECKING THE RADIATOR FAN MOTORS.....	8-136
CHECKING THE COOLANT TEMPERATURE SENSOR.....	8-136
CHECKING THE THROTTLE POSITION SENSOR	8-137
CHECKING THE ACCELERATOR POSITION SENSOR	8-138
CHECKING THE AIR INDUCTION SYSTEM SOLENOID	8-138
CHECKING THE ATMOSPHERIC PRESSURE SENSOR	8-138
CHECKING THE CYLINDER IDENTIFICATION SENSOR	8-139
CHECKING THE INTAKE AIR PRESSURE SENSOR	8-139
CHECKING THE INTAKE AIR TEMPERATURE SENSOR.....	8-140



- 6. Main fuse
- 7. Main switch
- 8. Battery
- 9. Frame ground
- 14. Relay unit
- 19. Sidestand switch
- 20. Crankshaft position sensor
- 24. Lean angle sensor
- 30. ECU (engine control unit)
- 32. Cylinder-#1 ignition coil
- 33. Cylinder-#2 ignition coil
- 34. Cylinder-#3 ignition coil
- 35. Cylinder-#4 ignition coil
- 36. Spark plug
- 63. Gear position switch
- 83. Engine stop switch
- 89. Ignition fuse

EAS2S31057

ENGINE STOPPING DUE TO SIDESTAND OPERATION

When the engine is running and the transmission is in gear, the engine will stop if the sidestand is moved down. This is because the electric current from the ignition coils does not flow to the ECU when both the gear position switch (neutral circuit) and sidestand switch are set to "OFF", thereby preventing the spark plugs from producing a spark. However, the engine continues to run under the following conditions:

- The transmission is in gear (the neutral circuit of the gear position switch is open) and the sidestand is up (the sidestand switch circuit is closed).
- The transmission is in neutral (the neutral circuit of the gear position switch is closed) and the side-stand is down (the sidestand switch circuit is open).

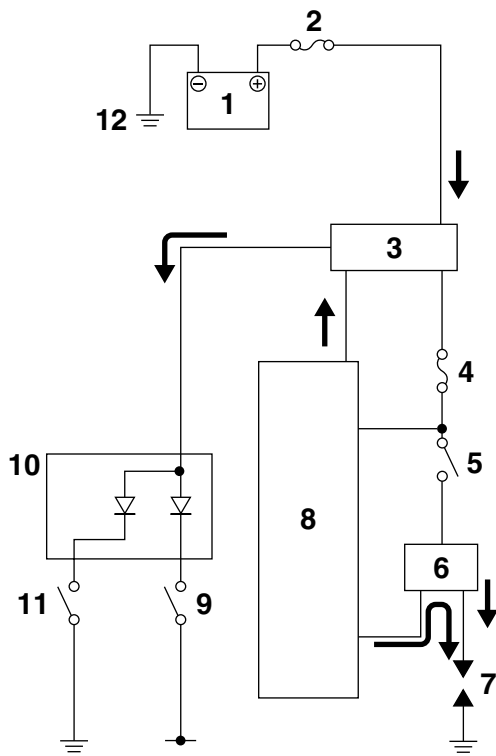

1. Battery
2. Main fuse
3. Main switch
4. Ignition fuse
5. Engine stop switch
6. Ignition coil
7. Spark plug
8. ECU (engine control unit)
9. Sidestand switch
10. Relay unit (diode)
11. Gear position switch (neutral circuit)

12. Frame ground

EAS27140

TROUBLESHOOTING

The ignition system fails to operate (no spark or intermittent spark).

TIP

• Before troubleshooting, remove the following part(s):

1. Top cover
2. Right side cover

<p>1. Check the fuses. (Main and ignition) Refer to "CHECKING THE FUSES" on page 8-125.</p>	<p>NG →</p>	<p>Replace the fuse(s).</p>
OK ↓		
<p>2. Check the battery. Refer to "CHECKING AND CHARGING THE BATTERY" on page 8-126.</p>	<p>NG →</p>	<ul style="list-style-type: none"> • Clean the battery terminals. • Recharge or replace the battery.
OK ↓		
<p>3. Check the spark plugs. Refer to "CHECKING THE SPARK PLUGS" on page 3-9.</p>	<p>NG →</p>	<p>Re-gap or replace the spark plug(s).</p>
OK ↓		
<p>4. Check the ignition spark gap. Refer to "CHECKING THE IGNITION SPARK GAP" on page 8-132.</p>	<p>OK →</p>	<p>Ignition system is OK.</p>
NG ↓		
<p>5. Check the ignition coils. Refer to "CHECKING THE IGNITION COILS" on page 8-131.</p>	<p>NG →</p>	<p>Replace the ignition coil(s).</p>
OK ↓		
<p>6. Check the crankshaft position sensor. Refer to "CHECKING THE CRANKSHAFT POSITION SENSOR" on page 8-132.</p>	<p>NG →</p>	<p>Replace the crankshaft position sensor/stator assembly.</p>
OK ↓		
<p>7. Check the main switch. Refer to "CHECKING THE SWITCHES" on page 8-121.</p>	<p>NG →</p>	<p>Replace the main switch.</p>
OK ↓		
<p>8. Check the engine stop switch. Refer to "CHECKING THE SWITCHES" on page 8-121.</p>	<p>NG →</p>	<p>Replace the right handlebar switch.</p>
OK ↓		

IGNITION SYSTEM

9. Check the gear position switch. Refer to "CHECKING THE SWITCHES" on page 8-121.	NG →	Replace the gear position switch.
OK ↓		
10. Check the sidestand switch. Refer to "CHECKING THE SWITCHES" on page 8-121.	NG →	Replace the sidestand switch.
OK ↓		
11. Check the relay unit (diode). Refer to "CHECKING THE RELAY UNIT (DIODE)" on page 8-130.	NG →	Replace the relay unit.
OK ↓		
12. Check the lean angle sensor. Refer to "CHECKING THE LEAN ANGLE SENSOR" on page 8-133.	NG →	Replace the lean angle sensor.
OK ↓		
13. Check the entire ignition system wiring. Refer to "CIRCUIT DIAGRAM" on page 8-1.	NG →	Properly connect or repair the ignition system wiring.
OK ↓		
Replace the ECU.		

EAS27160

ELECTRIC STARTING SYSTEM

EAS27170

CIRCUIT DIAGRAM

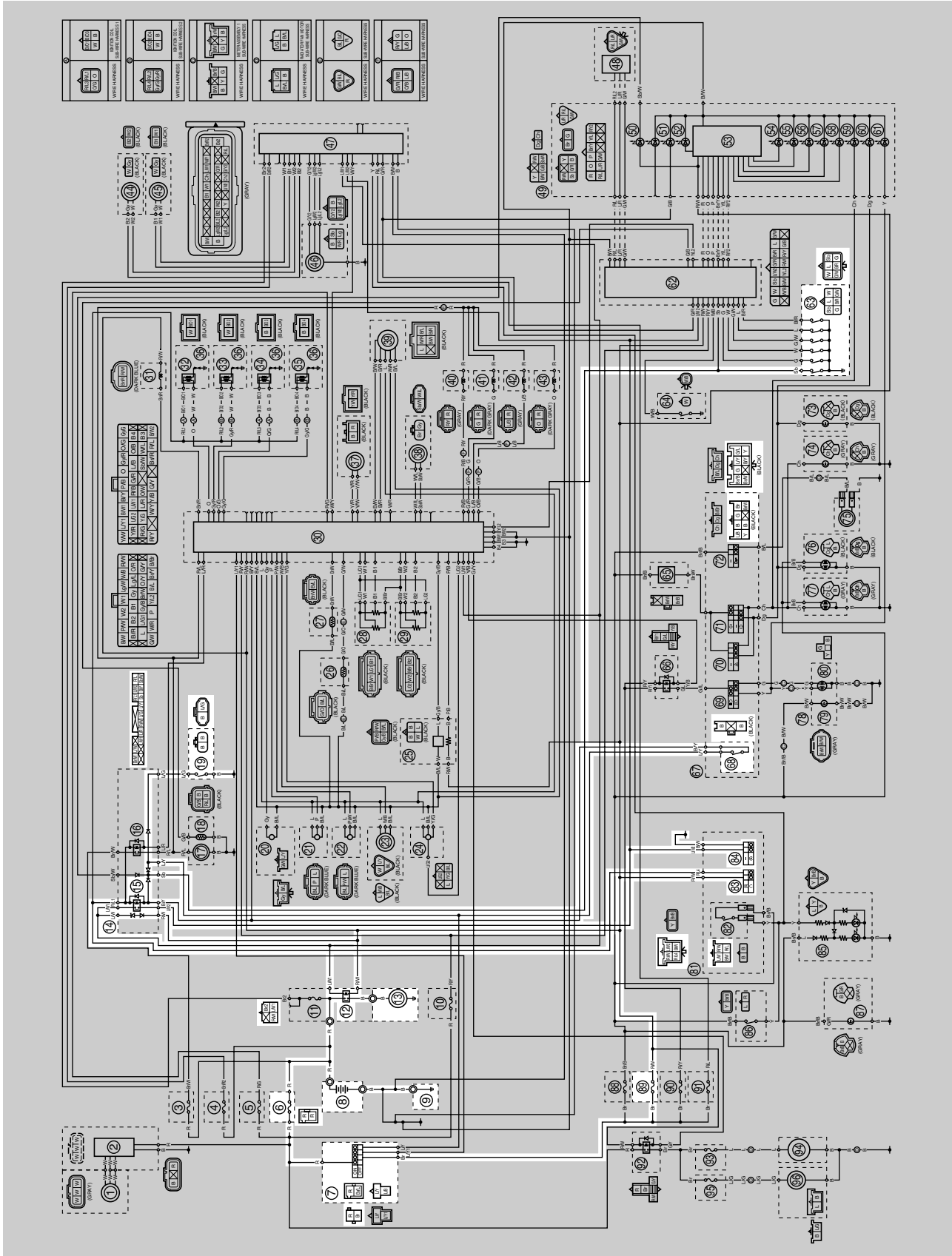

- 6. Main fuse
- 7. Main switch
- 8. Battery
- 9. Frame ground
- 12. Starter relay
- 13. Starter motor
- 14. Relay unit
- 15. Starting circuit cut-off relay
- 19. Sidestand switch
- 63. Gear position switch
- 68. Clutch switch
- 83. Engine stop switch
- 84. Start switch
- 89. Ignition fuse

EAS27180

STARTING CIRCUIT CUT-OFF SYSTEM OPERATION

If the engine stop switch is set to “○” and the main switch is set to “ON” (both switches are closed), the starter motor can only operate if at least one of the following conditions is met:

- The transmission is in neutral (the neutral circuit of the gear position switch is closed).
- The clutch lever is pulled to the handlebar (the clutch switch is closed) and the sidestand is up (the sidestand switch is closed).

The starting circuit cut-off relay prevents the starter motor from operating when neither of these conditions has been met. In this instance, the starting circuit cut-off relay is open so current cannot reach the starter motor. When at least one of the above conditions has been met, the starting circuit cut-off relay is closed and the engine can be started by pressing the start switch “⊗”.

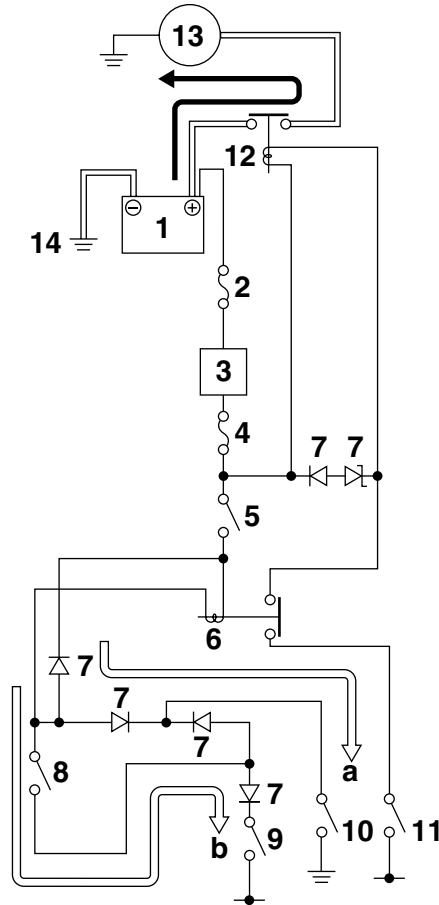

- | | |
|---|--------------------------|
| a. WHEN THE TRANSMISSION IS IN NEUTRAL | 8. Clutch switch |
| b. WHEN THE SIDESTAND IS UP AND THE CLUTCH LEVER IS PULLED TO THE HANDLEBAR | 9. Sidestand switch |
| 1. Battery | 10. Gear position switch |
| 2. Main fuse | 11. Start switch |
| 3. Main switch | 12. Starter relay |
| 4. Ignition fuse | 13. Starter motor |
| 5. Engine stop switch | 14. Frame ground |
| 6. Starting circuit cut-off relay | |
| 7. Relay unit (diode) | |

EAS27190

TROUBLESHOOTING

The starter motor fails to turn.

TIP

• Before troubleshooting, remove the following part(s):

1. Top cover
2. Right side cover

<p>1. Check the fuses. (Main and ignition) Refer to "CHECKING THE FUSES" on page 8-125.</p>	<p>NG →</p>	<p>Replace the fuse(s).</p>
OK ↓		
<p>2. Check the battery. Refer to "CHECKING AND CHARGING THE BATTERY" on page 8-126.</p>	<p>NG →</p>	<ul style="list-style-type: none"> • Clean the battery terminals. • Recharge or replace the battery.
OK ↓		
<p>3. Check the starter motor operation. Refer to "CHECKING THE STARTER MOTOR OPERATION" on page 8-133.</p>	<p>OK →</p>	<p>Starter motor is OK. Perform the electric starting system troubleshooting, starting with step 5.</p>
NG ↓		
<p>4. Check the starter motor. Refer to "CHECKING THE STARTER MOTOR" on page 5-46.</p>	<p>NG →</p>	<p>Repair or replace the starter motor.</p>
OK ↓		
<p>5. Check the relay unit (starting circuit cut-off relay). Refer to "CHECKING THE RELAYS" on page 8-129.</p>	<p>NG →</p>	<p>Replace the relay unit.</p>
OK ↓		
<p>6. Check the relay unit (diode). Refer to "CHECKING THE RELAY UNIT (DIODE)" on page 8-130.</p>	<p>NG →</p>	<p>Replace the relay unit.</p>
OK ↓		
<p>7. Check the starter relay. Refer to "CHECKING THE RELAYS" on page 8-129.</p>	<p>NG →</p>	<p>Replace the starter relay.</p>
OK ↓		
<p>8. Check the main switch. Refer to "CHECKING THE SWITCHES" on page 8-121.</p>	<p>NG →</p>	<p>Replace the main switch.</p>
OK ↓		

ELECTRIC STARTING SYSTEM

9. Check the engine stop switch. Refer to "CHECKING THE SWITCHES" on page 8-121.	NG →	Replace the right handlebar switch.
OK ↓		
10. Check the gear position switch. Refer to "CHECKING THE SWITCHES" on page 8-121.	NG →	Replace the gear position switch.
OK ↓		
11. Check the sidestand switch. Refer to "CHECKING THE SWITCHES" on page 8-121.	NG →	Replace the sidestand switch.
OK ↓		
12. Check the clutch switch. Refer to "CHECKING THE SWITCHES" on page 8-121.	NG →	Replace the clutch switch.
OK ↓		
13. Check the start switch. Refer to "CHECKING THE SWITCHES" on page 8-121.	NG →	Replace the right handlebar switch.
OK ↓		
14. Check the entire starting system wiring. Refer to "CIRCUIT DIAGRAM" on page 8-7.	NG →	Properly connect or repair the starting system wiring.
OK ↓		
The starting system circuit is OK.		

1. AC magneto
2. Rectifier/regulator
6. Main fuse
8. Battery
9. Frame ground

EAS27230

TROUBLESHOOTING

The battery is not being charged.

TIP

• Before troubleshooting, remove the following part(s):

1. Top cover
2. Passenger seat

<p>1. Check the fuse. (Main) Refer to "CHECKING THE FUSES" on page 8-125.</p>	<p>NG →</p>	<p>Replace the fuse.</p>
<p>OK ↓</p>		
<p>2. Check the battery. Refer to "CHECKING AND CHARGING THE BATTERY" on page 8-126.</p>	<p>NG →</p>	<ul style="list-style-type: none"> • Clean the battery terminals. • Recharge or replace the battery.
<p>OK ↓</p>		
<p>3. Check the stator coil. Refer to "CHECKING THE STATOR COIL" on page 8-134.</p>	<p>NG →</p>	<p>Replace the crankshaft position sensor/stator assembly.</p>
<p>OK ↓</p>		
<p>4. Check the rectifier/regulator. Refer to "CHECKING THE RECTIFIER/REGULATOR" on page 8-134.</p>	<p>NG →</p>	<p>Replace the rectifier/regulator.</p>
<p>OK ↓</p>		
<p>5. Check the entire charging system wiring. Refer to "CIRCUIT DIAGRAM" on page 8-13.</p>	<p>NG →</p>	<p>Properly connect or repair the charging system wiring.</p>
<p>OK ↓</p>		
<p>The charging system circuit is OK.</p>		

EAS27240

LIGHTING SYSTEM

EAS27250

CIRCUIT DIAGRAM

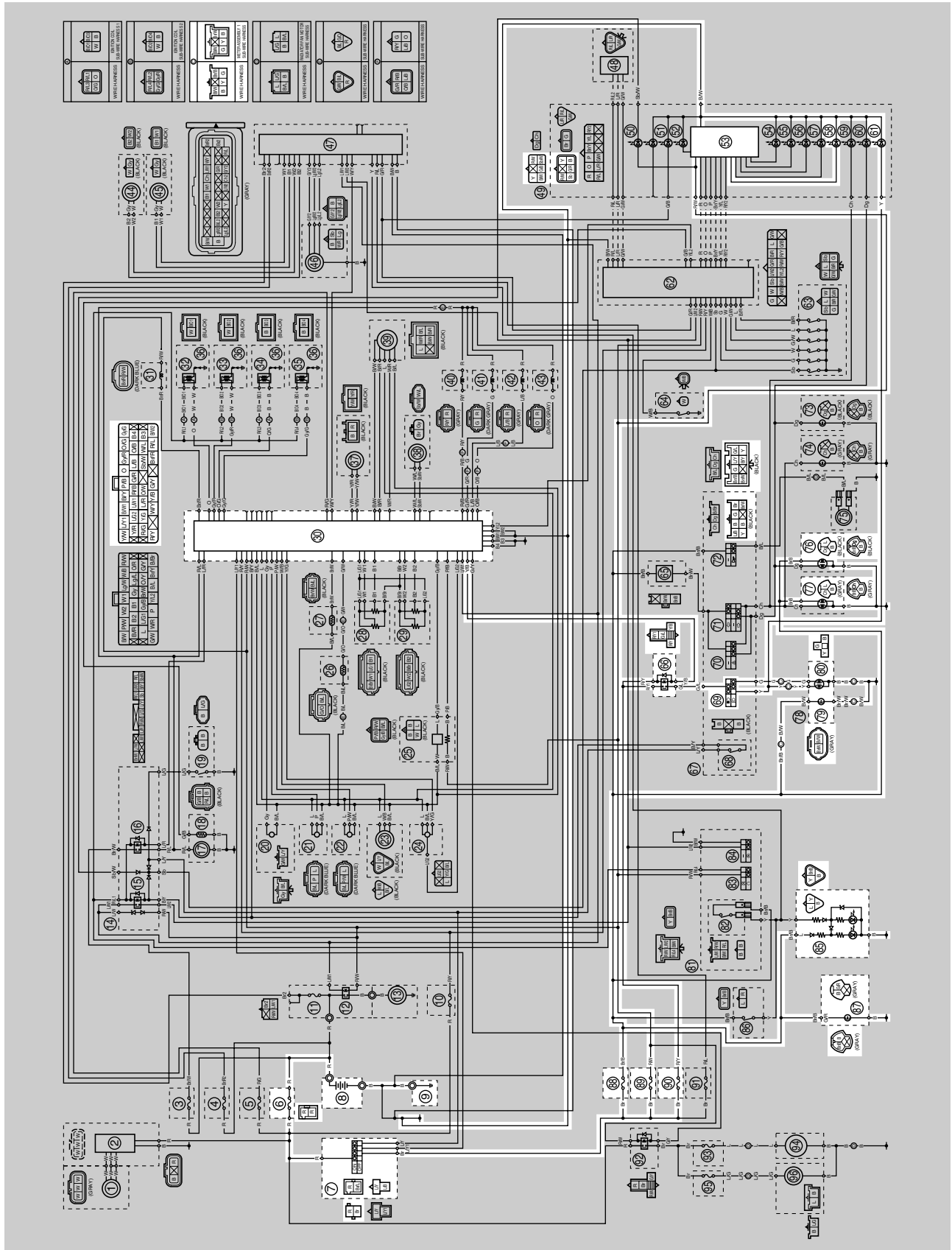

- 6. Main fuse
- 7. Main switch
- 8. Battery
- 9. Frame ground
- 30.ECU (engine control unit)
- 53.Multi-function meter
- 58.Meter light
- 61.High beam indicator light
- 66.Headlight relay
- 69.Dimmer switch
- 76.Front right turn signal/position light
- 77.Front left turn signal/position light
- 79.Auxiliary light
- 80.Headlight
- 85.Tail/brake light
- 87.License plate light
- 88.Signaling system fuse
- 89.Ignition fuse
- 90.Headlight fuse

EAS27260

TROUBLESHOOTING

Any of the following fail to light: headlight, high beam indicator light, taillight, license plate light, auxiliary light, position light or meter light.

TIP

• Before troubleshooting, remove the following part(s):

1. Top cover
2. Right side cover
3. Rear fender

<p>1. Check the condition of each bulb and bulb socket. Refer to "CHECKING THE BULBS AND BULB SOCKETS" on page 8-124.</p>	<p>NG →</p>	<p>Replace the bulb(s) and bulb socket(s).</p>
<p>OK ↓</p>		
<p>2. Check the fuses. (Main, headlight, ignition, and signaling system) Refer to "CHECKING THE FUSES" on page 8-125.</p>	<p>NG →</p>	<p>Replace the fuse(s).</p>
<p>OK ↓</p>		
<p>3. Check the battery. Refer to "CHECKING AND CHARGING THE BATTERY" on page 8-126.</p>	<p>NG →</p>	<ul style="list-style-type: none"> • Clean the battery terminals. • Recharge or replace the battery.
<p>OK ↓</p>		
<p>4. Check the main switch. Refer to "CHECKING THE SWITCHES" on page 8-121.</p>	<p>NG →</p>	<p>Replace the main switch.</p>
<p>OK ↓</p>		
<p>5. Check the dimmer switch. Refer to "CHECKING THE SWITCHES" on page 8-121.</p>	<p>NG →</p>	<p>Replace the left handlebar switch.</p>
<p>OK ↓</p>		
<p>6. Check the headlight relay. Refer to "CHECKING THE RELAYS" on page 8-129.</p>	<p>NG →</p>	<p>Replace the headlight relay.</p>
<p>OK ↓</p>		

7. Check the entire lighting system wiring.
Refer to "CIRCUIT DIAGRAM" on page 8-17.

OK ↓

Replace the ECU or meter assembly
1.

NG →

Properly connect or repair the lighting system wiring.

EAS27270

SIGNALING SYSTEM

EAS27280

CIRCUIT DIAGRAM

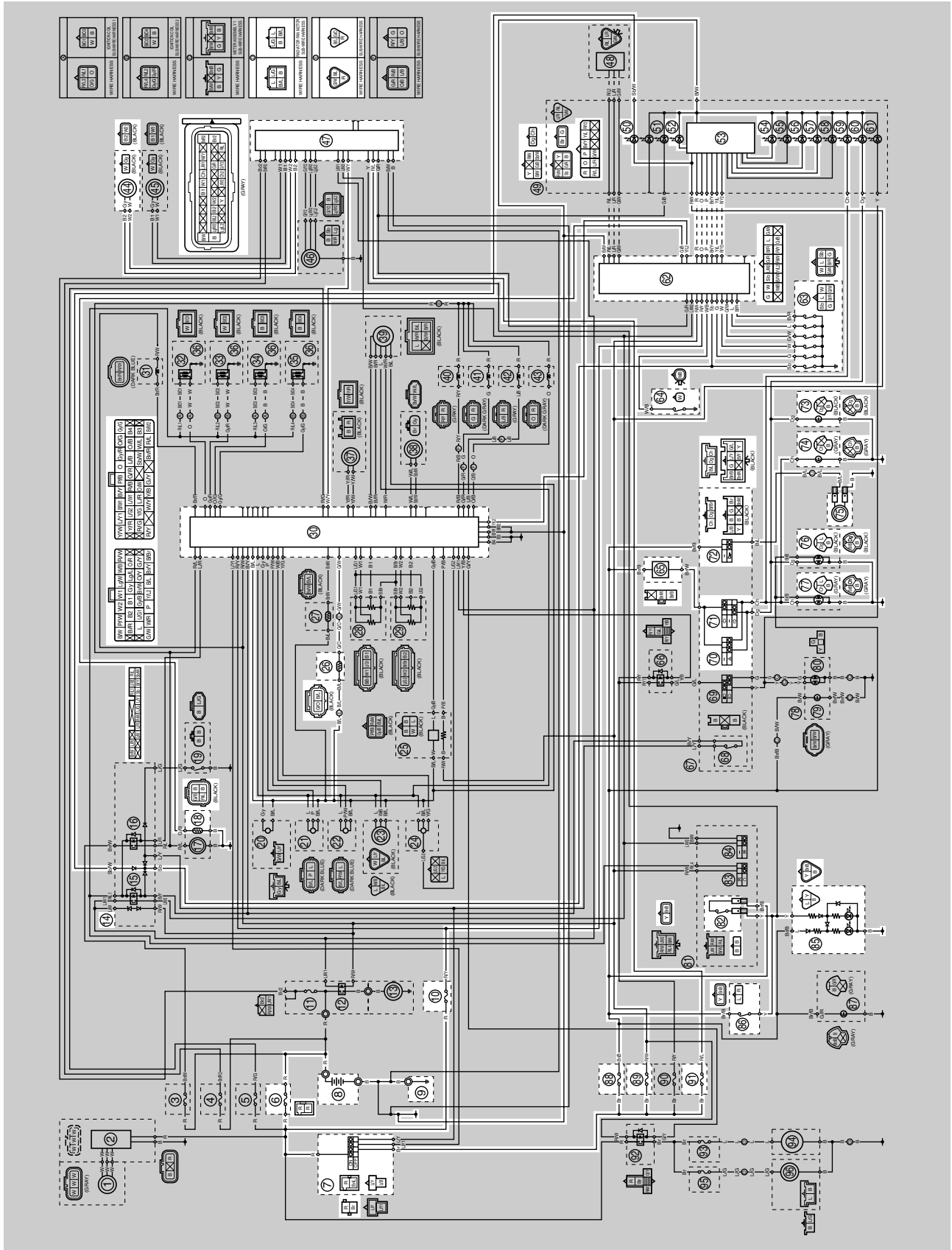

6. Main fuse
7. Main switch
8. Battery
9. Frame ground
- 10.Backup fuse (odometer and clock)
- 14.Relay unit
- 18.Fuel sender
- 26.Coolant temperature sensor
- 30.ECU (engine control unit)
- 44.Rear wheel sensor
- 47.ABS ECU (electronic control unit)
- 50.Neutral indicator light
- 52.Shift timing indicator light
- 53.Multi-function meter
- 54.Oil level warning light
- 56.Fuel level warning light
- 57.Coolant temperature warning light
- 59.Left turn signal indicator light
- 60.Right turn signal indicator light
- 62.Meter assembly 2
- 63.Gear position switch
- 64.Oil level switch
- 65.Turn signal/hazard relay
- 70.Hazard switch
- 71.Turn signal switch
- 72.Horn switch
- 73.Rear right turn signal light
- 74.Rear left turn signal light
- 75.Horn
- 76.Front right turn signal/position light
- 77.Front left turn signal/position light
- 82.Front brake light switch
- 85.Tail/brake light
- 86.Rear brake light switch
- 88.Signaling system fuse
- 89.Ignition fuse
- 91.ABS ECU fuse

EAS27290

TROUBLESHOOTING

- Any of the following fail to light: turn signal light, brake light or an indicator light.
- The horn fails to sound.
- The shift indicator fails to come on.
- The fuel meter fails to come on.
- The coolant temperature meter fails to come on.
- The speedometer fails to operate.

TIP

- Before troubleshooting, remove the following part(s):
 1. Top cover
 2. Right side cover
 3. Fuel tank

<p>1. Check the fuses. (Main, ignition, signaling system, backup, and ABS ECU) Refer to "CHECKING THE FUSES" on page 8-125.</p>	NG →	<p>Replace the fuse(s).</p>
OK ↓		
<p>2. Check the battery. Refer to "CHECKING AND CHARGING THE BATTERY" on page 8-126.</p>	NG →	<ul style="list-style-type: none"> • Clean the battery terminals. • Recharge or replace the battery.
OK ↓		
<p>3. Check the main switch. Refer to "CHECKING THE SWITCHES" on page 8-121.</p>	NG →	<p>Replace the main switch.</p>
OK ↓		
<p>4. Check the entire signaling system wiring. Refer to "CIRCUIT DIAGRAM" on page 8-21.</p>	NG →	<p>Properly connect or repair the signaling system wiring.</p>
OK ↓		
<p>Check the condition of each of the signaling system circuits. Refer to "Checking the signaling system".</p>		

Checking the signaling system

The horn fails to sound.

<p>1. Check the horn switch. Refer to "CHECKING THE SWITCHES" on page 8-121.</p>	NG →	<p>Replace the left handlebar switch.</p>
--	------	---

OK ↓

SIGNALING SYSTEM

2. Check the horn. Refer to "CHECKING THE HORN" on page 8-134.	NG →	Replace the horn.
OK ↓		
3. Check the entire signaling system wiring. Refer to "CIRCUIT DIAGRAM" on page 8-21.	NG →	Properly connect or repair the signaling system wiring.
OK ↓		
This circuit is OK.		
<u>The tail/brake light fails to come on.</u>		
1. Check the front brake light switch. Refer to "CHECKING THE SWITCHES" on page 8-121.	NG →	Replace the front brake light switch.
OK ↓		
2. Check the rear brake light switch. Refer to "CHECKING THE SWITCHES" on page 8-121.	NG →	Replace the rear brake light switch.
OK ↓		
3. Check the entire signaling system wiring. Refer to "CIRCUIT DIAGRAM" on page 8-21.	NG →	Properly connect or repair the signaling system wiring.
OK ↓		
Replace the tail/brake light assembly.		
<u>The turn signal light, turn signal indicator light or both fail to blink.</u>		
1. Check the turn signal light bulbs and sockets. Refer to "CHECKING THE BULBS AND BULB SOCKETS" on page 8-124.	NG →	Replace the turn signal light bulb, socket or both.
OK ↓		
2. Check the turn signal switch. Refer to "CHECKING THE SWITCHES" on page 8-121.	NG →	Replace the left handlebar switch.
OK ↓		
3. Check the hazard switch. Refer to "CHECKING THE SWITCHES" on page 8-121.	NG →	Replace the left handlebar switch.
OK ↓		

SIGNALING SYSTEM

<p>4. Check the turn signal/hazard relay. Refer to "CHECKING THE TURN SIGNAL/HAZARD RELAY" on page 8-130.</p>	NG →	Replace the turn signal/hazard relay.
OK ↓		
<p>5. Check the entire signaling system wiring. Refer to "CIRCUIT DIAGRAM" on page 8-21.</p>	NG →	Properly connect or repair the signaling system wiring.
OK ↓		
<p>Replace the meter assembly 1.</p>		
<u>The neutral indicator light fails to come on.</u>		
<p>1. Check the gear position switch. Refer to "CHECKING THE SWITCHES" on page 8-121.</p>	NG →	Replace the gear position switch.
OK ↓		
<p>2. Check the relay unit (diode). Refer to "CHECKING THE RELAY UNIT (DIODE)" on page 8-130.</p>	NG →	Replace the relay unit.
OK ↓		
<p>3. Check the entire signaling system wiring. Refer to "CIRCUIT DIAGRAM" on page 8-21.</p>	NG →	Properly connect or repair the signaling system wiring.
OK ↓		
<p>Replace the meter assembly 1.</p>		
<u>The shift indicator fails to come on.</u>		
<p>1. Check the gear position switch. Refer to "CHECKING THE SWITCHES" on page 8-121.</p>	NG →	Replace the gear position switch.
OK ↓		

SIGNALING SYSTEM

2. Check the entire signaling system wiring.
Refer to "CIRCUIT DIAGRAM" on page 8-21.

NG →

Properly connect or repair the signaling system wiring.

OK ↓

Replace the meter assembly 2.

The oil level warning light fails to come on.

1. Check the oil level switch.
Refer to "CHECKING THE OIL LEVEL SWITCH" on page 8-135.

NG →

Replace the oil level switch.

OK ↓

2. Check the entire signaling system wiring.
Refer to "CIRCUIT DIAGRAM" on page 8-21.

NG →

Properly connect or repair the signaling system wiring.

OK ↓

Replace the meter assembly 1 or meter assembly 2.

The fuel meter, fuel level warning light, or both fail to come on.

1. Check the fuel sender.
Refer to "CHECKING THE FUEL SENDER" on page 8-135.

NG →

Replace the fuel pump assembly.

OK ↓

2. Check the entire signaling system wiring.
Refer to "CIRCUIT DIAGRAM" on page 8-21.

NG →

Properly connect or repair the signaling system wiring.

OK ↓

Replace the meter assembly 1 or meter assembly 2.

The coolant temperature meter, coolant temperature warning light, or both fail to come on.

1. Check the coolant temperature sensor.
Refer to "CHECKING THE COOLANT TEMPERATURE SENSOR" on page 8-136.

NG →

Replace the coolant temperature sensor.

OK ↓

2. Check the entire signaling system wiring.
Refer to "CIRCUIT DIAGRAM" on page 8-21.

NG →

Properly connect or repair the signaling system wiring.

OK ↓

Replace the ECU, meter assembly 1 or meter assembly 2.

The shift timing indicator light fails to come on.

1. Check that the shift timing indicator light is set to come on and that the brightness level of the light is adjusted properly.
Refer to "FEATURES" on page 1-2.

NG →

Replace the meter assembly 1.

OK ↓

2. Check the entire signaling system wiring.
Refer to "CIRCUIT DIAGRAM" on page 8-21.

NG →

Properly connect or repair the signaling system wiring.

OK ↓

This circuit is OK.

The speedometer fails to operate.

1. Check the rear wheel sensor.
Refer to "MAINTENANCE OF THE REAR WHEEL SENSOR AND SENSOR ROTOR" on page 4-24.

NG →

Replace the rear wheel sensor.

OK ↓

2. Check the entire speed sensor wiring.
Refer to TIP.

NG →

Properly connect or repair the speed sensor wiring.

OK ↓

Replace the hydraulic unit assembly, ECU, meter assembly 1 or meter assembly 2.

TIP

Repair or replace if there is an open or short circuit.

- Between rear wheel sensor coupler and ABS ECU coupler.
(white–white)
(black–black)
- Between ABS ECU coupler and ECU coupler.
(white/yellow–white/yellow)
- Between ECU coupler and meter assembly 2 coupler.
(yellow/blue–yellow/blue)

EAS27300

COOLING SYSTEM

EAS27310

CIRCUIT DIAGRAM

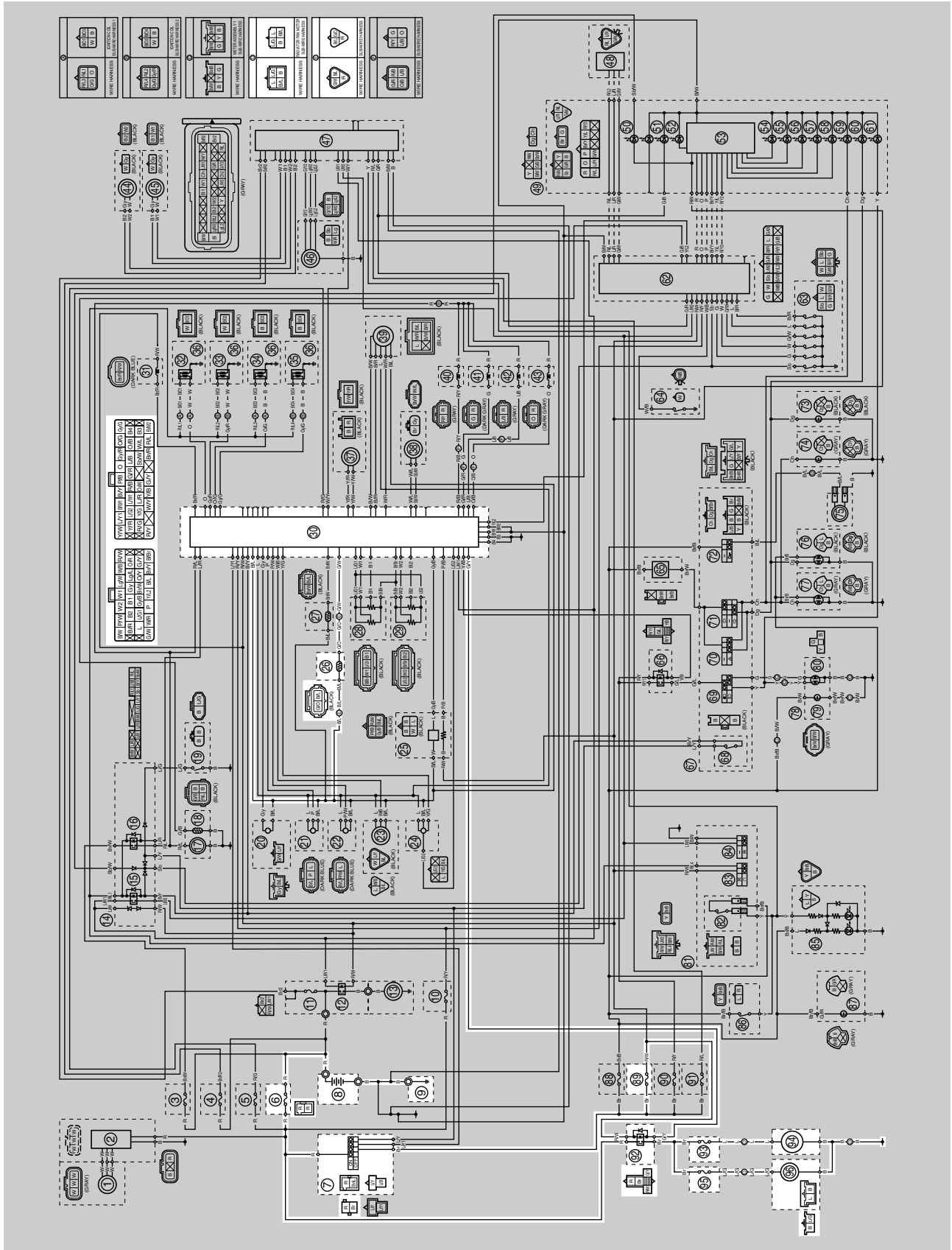

- 6. Main fuse
- 7. Main switch
- 8. Battery
- 9. Frame ground
- 26. Coolant temperature sensor
- 30. ECU (engine control unit)
- 89. Ignition fuse
- 92. Radiator fan motor relay
- 93. Main radiator fan motor fuse
- 94. Main radiator fan motor
- 95. Sub radiator fan motor fuse
- 96. Sub radiator fan motor

EAS27320

TROUBLESHOOTING

The radiator fan motor fails to turn.

TIP

• Before troubleshooting, remove the following part(s):

1. Top cover
2. Right side cover
3. Rear fender

<p>1. Check the fuses. (Main, ignition, main radiator fan motor, and sub radiator fan motor) Refer to "CHECKING THE FUSES" on page 8-125.</p>	<p>NG →</p>	<p>Replace the fuse(s).</p>
OK ↓		
<p>2. Check the battery. Refer to "CHECKING AND CHARGING THE BATTERY" on page 8-126.</p>	<p>NG →</p>	<ul style="list-style-type: none"> • Clean the battery terminals. • Recharge or replace the battery.
OK ↓		
<p>3. Check the main switch. Refer to "CHECKING THE SWITCHES" on page 8-121.</p>	<p>NG →</p>	<p>Replace the main switch.</p>
OK ↓		
<p>4. Check the radiator fan motors. Refer to "CHECKING THE RADIATOR FAN MOTORS" on page 8-136.</p>	<p>NG →</p>	<p>Replace the radiator fan motor(s).</p>
OK ↓		
<p>5. Check the radiator fan motor relay. Refer to "CHECKING THE RELAYS" on page 8-129.</p>	<p>NG →</p>	<p>Replace the radiator fan motor relay.</p>
OK ↓		
<p>6. Check the coolant temperature sensor. Refer to "CHECKING THE COOLANT TEMPERATURE SENSOR" on page 8-136.</p>	<p>NG →</p>	<p>Replace the coolant temperature sensor.</p>
OK ↓		
<p>7. Check the entire cooling system wiring. Refer to "CIRCUIT DIAGRAM" on page 8-29.</p>	<p>NG →</p>	<p>Properly connect or repair the cooling system wiring.</p>
OK ↓		
<p>Replace the ECU.</p>		

3. Fuel injection system fuse
5. Electric throttle valve fuse
6. Main fuse
7. Main switch
8. Battery
9. Frame ground
12. Starter relay
14. Relay unit
15. Starting circuit cut-off relay
16. Fuel pump relay
17. Fuel pump
19. Sidestand switch
20. Crankshaft position sensor
21. Atmospheric pressure sensor
22. Intake air pressure sensor
23. Cylinder identification sensor
24. Lean angle sensor
25. O₂ sensor
26. Coolant temperature sensor
27. Intake air temperature sensor
28. Accelerator position sensor
29. Throttle position sensor
30. ECU (engine control unit)
31. Air induction system solenoid
32. Cylinder-#1 ignition coil
33. Cylinder-#2 ignition coil
34. Cylinder-#3 ignition coil
35. Cylinder-#4 ignition coil
36. Spark plug
37. Throttle servo motor
38. Intake funnel servo motor
39. EXUP servo motor
40. Injector #1
41. Injector #2
42. Injector #3
43. Injector #4
44. Rear wheel sensor
47. ABS ECU (electronic control unit)
48. SELECT/RESET button unit
53. Multi-function meter
55. Engine trouble warning light
62. Meter assembly 2
63. Gear position switch
66. Headlight relay
83. Engine stop switch
84. Start switch
89. Ignition fuse
90. Headlight fuse
91. ABS ECU fuse
92. Radiator fan motor relay

EAS27350

ECU SELF-DIAGNOSTIC FUNCTION

The ECU is equipped with a self-diagnostic function in order to ensure that the fuel injection system is operating normally. If this function detects a malfunction in the system, it immediately operates the engine under substitute characteristics and illuminates the engine trouble warning light to alert the rider that a malfunction has occurred in the system. Once a malfunction has been detected, a fault code is stored in the memory of the ECU.

- To inform the rider that the fuel injection system is not functioning, the engine trouble warning light flashes when the start switch is being pushed to start the engine.
- If a malfunction is detected in the system by the self-diagnostic function, the ECU provides an appropriate substitute characteristic operation, and alerts the rider of the detected malfunction by illuminating the engine trouble warning light.
- After the engine has been stopped, the lowest fault code number appears on the odometer LCD. Once a fault code has been displayed, it remains stored in the memory of the ECU until it is deleted.

Engine trouble warning light indication and fuel injection system operation

Warning light indication	ECU operation	Fuel injection operation	Vehicle operation
Flashing*	Warning provided when unable to start engine	Operation stopped	Cannot be operated
Remains on	Malfunction detected	Operated with substitute characteristics in accordance with the description of the malfunction	Can or cannot be operated depending on the fault code

* The warning light flashes when any one of the conditions listed below is present and the start switch is pushed:

11: Cylinder identification sensor	30: Lean angle sensor (latch up detected)
12: Crankshaft position sensor	41: Lean angle sensor (open or short-circuit)
19: Blue/yellow ECU lead (broken or disconnected)	50: ECU internal malfunction (memory check error)

Checking for a defective engine trouble warning light bulb

The engine trouble warning light comes on for 1.4 seconds after the main switch has been turned to "ON" and it comes on while the start switch is being pushed. If the warning light does not come on under these conditions, the warning light (LED) may be defective.

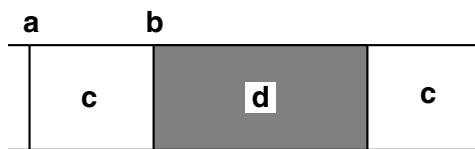

- a. Main switch “OFF”
- b. Main switch “ON”
- c. Engine trouble warning light off
- d. Engine trouble warning light on for 1.4 seconds

ECU detects an abnormal signal from a sensor

If the ECU detects an abnormal signal from a sensor while the vehicle is being driven, the ECU illuminates the engine trouble warning light and provides the engine with alternate operating instructions that are appropriate for the type of malfunction.

When an abnormal signal is received from a sensor, the ECU processes the specified values that are programmed for each sensor in order to provide the engine with alternate operating instructions that enable the engine to continue to operate or stop operating, depending on the conditions.

EAS27400

TROUBLESHOOTING METHOD

The engine operation is not normal and the engine trouble warning light comes on.

1. Check:

- Fault code number



- a. Check the fault code number displayed on the meter.
- b. Identify the faulty system with the fault code.
- c. Identify the probable cause of the malfunction.



2. Check and repair the probable cause of malfunction.

Fault code No.	No fault code No.
Check and repair. Refer to “TROUBLESHOOTING DETAILS” on page 8-43. Monitor the operation of the sensors and actuators in the diagnostic mode. Refer to “Sensor operation table” and “Actuator operation table”.	Check and repair.

- 3. Perform fuel injection system reinstatement action.
Refer to “Reinstatement method” of table in “TROUBLESHOOTING DETAILS”.
- 4. Turn the main switch to “OFF” and back to “ON”, then check that no fault code number is displayed.

TIP _____

If fault codes are displayed, repeat steps (1) to (4) until no fault code number is displayed.

- 5. Erase the malfunction history in the diagnostic mode. Refer to “Sensor operation table (Diagnostic code No. D:62)”.

TIP _____

Turning the main switch to “OFF” will not erase the malfunction history.

The engine operation is not normal but the engine trouble warning light does not come on.

1. Check the operation of following sensors and actuators in the Diagnostic mode. Refer to “Sensor operation table” and “Actuator operation table”.

D:01: Throttle position sensor signal 1 (throttle angle)
D:13: Throttle position sensor signal 2 (throttle angle)
D:14: Accelerator position sensor signal 1 (throttle angle)
D:15: Accelerator position sensor signal 2 (throttle angle)
D:30: Cylinder-#1 ignition coil
D:31: Cylinder-#2 ignition coil
D:32: Cylinder-#3 ignition coil
D:33: Cylinder-#4 ignition coil
D:36: Injector #1
D:37: Injector #2
D:38: Injector #3
D:39: Injector #4
D:48: Air induction system solenoid

If a malfunction is detected in the sensors or actuators, repair or replace all faulty parts. If no malfunction is detected in the sensors and actuators, check and repair inner parts of the engine.

EAS27421

DIAGNOSTIC MODE

Setting the diagnostic mode

1. Turn the main switch to “OFF”.
2. Disconnect the wire harness coupler from the fuel pump.
3. Simultaneously press and hold the “SELECT” and “RESET” buttons, turn the main switch to “ON”, and continue to press the buttons for 8 seconds or more.

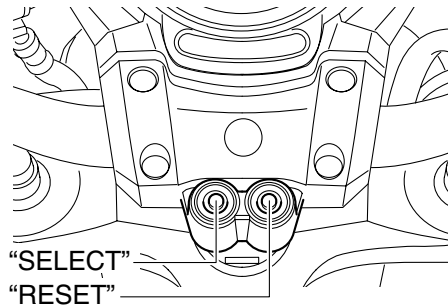

TIP

- All displays on the meter disappear except the odometer displays.
- “DIAG” appears on the odometer LCD.

4. Simultaneously press the “SELECT” and “RESET” buttons for 2 seconds or more to activate the diagnostic mode. The diagnostic code number “D:01” appears on the clock LCD.
5. Select the diagnostic code number corresponding to the fault code number by pressing the “SELECT” and “RESET” buttons.

TIP

- To decrease the selected diagnostic code number, press the “RESET” button. Press the “RESET” button for 1 second or longer to automatically decrease the diagnostic code numbers.

FUEL INJECTION SYSTEM

- To increase the selected diagnostic code number, press the “SELECT” button. Press the “SELECT” button for 1 second or longer to automatically increase the diagnostic code numbers.

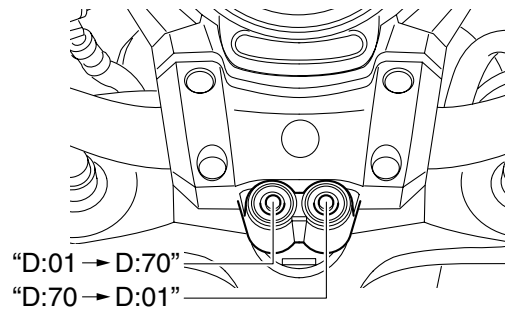

6. Verify the operation of the sensor or actuator.
 - Sensor operation
The data representing the operating conditions of the sensor appears on the odometer LCD.
 - Actuator operation
Set the engine stop switch to “○” to operate the actuator.

TIP

If the engine stop switch is set to “○”, set it to “⊗”, and then set it to “○” again.

7. Turn the main switch to “OFF” to cancel the diagnostic mode.

Sensor operation table

Diagnostic code No.	Item	Meter display	Checking method
D:01	Throttle position sensor signal 1 • Fully closed position • Fully opened position	15–16 97–102	Check with throttle valves fully closed. Check with throttle valves fully open.
D:02	Atmospheric pressure	Displays the atmospheric pressure.	Compare the actually measured atmospheric pressure with the meter display value.
D:03	Pressure difference (atmospheric pressure and intake air pressure)	Displays the intake air pressure.	Set the engine stop switch to “○”, and then push the start switch “⊗”. (If the display value changes, the performance is OK.)
D:05	Intake air temperature	Displays the intake air temperature.	Compare the actually measured intake air temperature with the meter display value.
D:06	Coolant temperature	Displays the coolant temperature.	Compare the actually measured coolant temperature with the meter display value.

FUEL INJECTION SYSTEM

Diagnostic code No.	Item	Meter display	Checking method
D:07	Vehicle speed pulse	0–999	Check that the number increases when the rear wheel is rotated. The number is cumulative and does not reset each time the wheel is stopped.
D:08	Lean angle sensor <ul style="list-style-type: none"> • Upright • Overturned 	0.4–1.4 3.8–4.2	Remove the lean angle sensor and incline it more than 65 degrees.
D:09	Fuel system voltage (battery voltage)	Approximately 12.0	Set the engine stop switch to “○”, and then compare with the actually measured battery voltage. (If the battery voltage is lower, perform recharging.)
D:13	Throttle position sensor signal 2 <ul style="list-style-type: none"> • Fully closed position • Fully opened position 	15–16 97–102	Check with throttle valves fully closed. Check with throttle valves fully open.
D:14	Accelerator position sensor signal 1 <ul style="list-style-type: none"> • Fully closed position • Fully opened position 	15–16 97–102	Check with throttle grip fully closed. Check with throttle grip fully open.
D:15	Accelerator position sensor signal 2 <ul style="list-style-type: none"> • Fully closed position • Fully opened position 	15–16 97–102	Check with throttle grip fully closed. Check with throttle grip fully open.
D:20	Sidestand switch <ul style="list-style-type: none"> • Stand retracted • Stand extended 	ON OFF	Set on/off the sidestand switch. (with the transmission in gear)
D:21	Gear position switch <ul style="list-style-type: none"> • Neutral • In gear 	ON OFF	Shift the transmission.

FUEL INJECTION SYSTEM

Diagnostic code No.	Item	Meter display	Checking method
D:60	EEPROM fault code display <ul style="list-style-type: none"> • No history • History exists 	00 01–04 (Cylinder fault code) <ul style="list-style-type: none"> • (If more than one cylinder is defective, the display alternates every two seconds to show all the detected cylinder numbers. When all cylinder numbers are shown, the display repeats the same process.) 	—
D:61	Malfunction history code display <ul style="list-style-type: none"> • No history • History exists 	00 Fault codes 11–70 <ul style="list-style-type: none"> • (If more than one code number is detected, the display alternates every two seconds to show all the detected code numbers. When all code numbers are shown, the display repeats the same process.) 	—
D:62	Malfunction history code erasure <ul style="list-style-type: none"> • No history • History exists 	0 <ul style="list-style-type: none"> • Displays the total number of malfunctions, including the current malfunction, that have occurred since the history was last erased. (For example, if there have been three malfunctions, “03” is displayed.) 	— To erase the history, set the engine stop switch from “⊗” to “○”.
D:63	Malfunction code reinstatement (for fault code No. 24 only) <ul style="list-style-type: none"> • No malfunction code • Malfunction code exists 	00 Fault code 24 <ul style="list-style-type: none"> • (If more than one code number is detected, the display alternates every two seconds to show all the detected code numbers. When all code numbers are shown, the display repeats the same process.) 	— To reinstate, set the engine stop switch from “⊗” to “○”.

FUEL INJECTION SYSTEM

Diagnostic code No.	Item	Meter display	Checking method
D:70	Control number	0-254 [-]	—

Actuator operation table

Diagnostic code No.	Item	Actuation	Checking method
D:30	Cylinder-#1 ignition coil	Actuates the cylinder-#1 ignition coil five times at one-second intervals. Illuminates the engine trouble warning light.	Check the spark five times. • Connect an ignition checker.
D:31	Cylinder-#2 ignition coil	Actuates the cylinder-#2 ignition coil five times at one-second intervals. Illuminates the engine trouble warning light.	Check the spark five times. • Connect an ignition checker.
D:32	Cylinder-#3 ignition coil	Actuates the cylinder-#3 ignition coil five times at one-second intervals. Illuminates the engine trouble warning light.	Check the spark five times. • Connect an ignition checker.
D:33	Cylinder-#4 ignition coil	Actuates the cylinder-#4 ignition coil five times at one-second intervals. Illuminates the engine trouble warning light.	Check the spark five times. • Connect an ignition checker.
D:34	Intake funnel servo motor	Actuates the intake funnels (up position down, position for each 3 seconds). Illuminates the engine trouble warning light.	Check the operating sound of the intake funnel servo motor.
D:36	Injector #1	Actuates the injector #1 five times at one-second intervals. Illuminates the engine trouble warning light.	Check the operating sound of the injector #1 five times.
D:37	Injector #2	Actuates the injector #2 five times at one-second intervals. Illuminates the engine trouble warning light.	Check the operating sound of the injector #2 five times.
D:38	Injector #3	Actuates the injector #3 five times at one-second intervals. Illuminates the engine trouble warning light.	Check the operating sound of the injector #3 five times.

FUEL INJECTION SYSTEM

Diagnostic code No.	Item	Actuation	Checking method
D:39	Injector #4	Actuates the injector #4 five times at one-second intervals. Illuminates the engine trouble warning light.	Check the operating sound of the injector #4 five times.
D:48	Air induction system solenoid	Actuates the air induction system solenoid five times at one-second intervals. Illuminates the engine trouble warning light.	Check the operating sound of the air induction system solenoid five times.
D:50	Fuel pump relay	Actuates the fuel pump relay five times at one-second intervals. Illuminates the engine trouble warning light. (The engine trouble warning light is OFF when the relay is ON, and the engine trouble warning light is ON when the relay is OFF).	Check the operating sound of the fuel pump relay five times.
D:51	Radiator fan motor relay	Actuates the radiator fan motor relay for five cycles of five seconds. (ON 2 seconds, OFF 3 seconds) Illuminates the engine trouble warning light.	Check the operating sound of the radiator fan motor relay five times.
D:52	Headlight relay	Actuates the headlight relay for five cycles of five seconds. (ON 2 seconds, OFF 3 seconds) Illuminates the engine trouble warning light.	Check the operating sound of the headlight relay five times.
D:53	EXUP servo motor	Actuates the EXUP servo motor (turns to open side and to closed side). Illuminates the engine trouble warning light.	Check the operating sound.

FUEL INJECTION SYSTEM

EAS27461

TROUBLESHOOTING DETAILS

This section describes the measures per fault code number displayed on the meter. Check and service the items or components that are the probable cause of the malfunction following the order given. After the check and service of the malfunctioning part has been completed, reset the meter display according to the reinstatement method.

Fault code No.:

Code number displayed on the meter when the engine failed to work normally.

Diagnostic code No.:

Diagnostic code number to be used when the diagnostic mode is operated. Refer to "DIAGNOSTIC MODE" on page 8-37.

Fault code No.	11	
Item	Cylinder identification sensor: no normal signals are received from the cylinder identification sensor.	
Fail-safe system	Unable to start engine	
	Able to drive vehicle	
Diagnostic code No.	—	
Meter display	—	
Checking method	—	
Probable cause of malfunction		Check or maintenance job
1	Installed condition of cylinder identification sensor.	<ul style="list-style-type: none"> • Check for looseness or pinching.
2	Connections <ul style="list-style-type: none"> • Cylinder identification sensor coupler • Wire harness ECU coupler 	<ul style="list-style-type: none"> • Check the coupler for any pins that may be pulled out. • Check the locking condition of the coupler. • If there is a malfunction, repair it and connect the coupler securely.
3	Open or short circuit in wire harness.	<ul style="list-style-type: none"> • Repair or replace if there is an open or short circuit. • Between cylinder identification sensor coupler and ECU coupler. (blue–blue) (white/black–white/black) (black/blue–black/blue)
4	Defective cylinder identification sensor.	<ul style="list-style-type: none"> • Replace if defective. Refer to "CHECKING THE CYLINDER IDENTIFICATION SENSOR" on page 8-139.
Reinstatement method	Starting the engine and operating it at idle.	

Fault code No.	12	
Item	Crankshaft position sensor: no normal signals are received from the crankshaft position sensor.	
Fail-safe system	Unable to start engine	
	Unable to drive vehicle	

FUEL INJECTION SYSTEM

Fault code No.	12	
Item	Crankshaft position sensor: no normal signals are received from the crankshaft position sensor.	
Diagnostic code No.	—	
Meter display	—	
Checking method	—	
	Probable cause of malfunction	Check or maintenance job
1	Installed condition of crankshaft position sensor.	<ul style="list-style-type: none"> • Check for looseness or pinching.
2	Connections <ul style="list-style-type: none"> • Crankshaft position sensor coupler • Wire harness ECU coupler 	<ul style="list-style-type: none"> • Check the coupler for any pins that may be pulled out. • Check the locking condition of the coupler. • If there is a malfunction, repair it and connect the coupler securely.
3	Open or short circuit in wire harness.	<ul style="list-style-type: none"> • Repair or replace if there is an open or short circuit. • Between the crankshaft position sensor coupler and ECU coupler. (gray–gray) (black/blue–black/blue)
4	Defective crankshaft position sensor.	<ul style="list-style-type: none"> • Replace if defective. Refer to “CHECKING THE CRANKSHAFT POSITION SENSOR” on page 8-132.
Reinstatement method	Cranking the engine.	

Fault code No.	13	
Item	Intake air pressure sensor: open or short circuit detected.	
Fail-safe system	Able to start engine	
	Able to drive vehicle	
Diagnostic code No.	D:03	
Meter display	Displays the intake air pressure.	
Checking method	Set the engine stop switch to “○”, and then push the start switch “⊗”. (If the display value changes, the performance is OK.)	
	Probable cause of malfunction	Check or maintenance job
1	Connections <ul style="list-style-type: none"> • Intake air pressure sensor coupler • Wire harness ECU coupler 	<ul style="list-style-type: none"> • Check the coupler for any pins that may be pulled out. • Check the locking condition of the coupler. • If there is a malfunction, repair it and connect the coupler securely.
2	Open or short circuit in wire harness.	<ul style="list-style-type: none"> • Repair or replace if there is an open or short circuit. • Between intake air pressure sensor coupler and ECU coupler. (black/blue–black/blue) (pink/white–pink/white) (blue–blue)

FUEL INJECTION SYSTEM

Fault code No.	13	
Item	Intake air pressure sensor: open or short circuit detected.	
3	Defective intake air pressure sensor.	<ul style="list-style-type: none"> • Execute the diagnostic mode. (Code No. D:03) • Replace if defective. Refer to "CHECKING THE INTAKE AIR PRESSURE SENSOR" on page 8-139.
Reinstatement method	Turning the main switch to "ON".	

Fault code No.	14	
Item	Intake air pressure sensor: hose system malfunction (clogged or detached hose).	
Fail-safe system	Able to start engine	
	Able to drive vehicle	
Diagnostic code No.	D:03	
Meter display	Displays the intake air pressure.	
Checking method	—	
	Probable cause of malfunction	Check or maintenance job
1	Intake air pressure sensor hose.	<ul style="list-style-type: none"> • Check the intake air pressure sensor hose condition. • Repair or replace the sensor hose.
2	Intake air pressure sensor malfunction at intermediate electrical potential.	<ul style="list-style-type: none"> • Check and repair the connection. • Replace it if there is a malfunction.
3	Connections <ul style="list-style-type: none"> • Intake air pressure sensor coupler • Wire harness ECU coupler 	<ul style="list-style-type: none"> • Check the coupler for any pins that may be pulled out. • Check the locking condition of the coupler. • If there is a malfunction, repair it and connect the coupler securely.
Reinstatement method	Starting the engine and operating it at idle.	

Fault code No.	15	
Item	Throttle position sensor: open or short circuit detected.	
Fail-safe system	Able/Unable to start engine	
	Able/Unable to drive vehicle	
Diagnostic code No.	D:01, D:13	
D:01	Meter display	Throttle position sensor signal 1 <ul style="list-style-type: none"> • 15–16 (fully closed position) • 97–102 (fully opened position)
	Checking method	<ul style="list-style-type: none"> • Check with throttle valve fully closed. • Check with throttle valve fully opened.

FUEL INJECTION SYSTEM

Fault code No.		15	
Item		Throttle position sensor: open or short circuit detected.	
D:13	Meter display	Throttle position sensor signal 2 <ul style="list-style-type: none"> • 15–16 (fully closed position) • 97–102 (fully opened position) 	
	Checking method	<ul style="list-style-type: none"> • Check with throttle valve fully closed. • Check with throttle valve fully opened. 	
Probable cause of malfunction		Check or maintenance job	
1	Installed condition of throttle position sensor.	<ul style="list-style-type: none"> • Check for looseness or pinching. • Check that the sensor is installed in the specified position. 	
2	Connections <ul style="list-style-type: none"> • Throttle position sensor coupler • Wire harness ECU coupler 	<ul style="list-style-type: none"> • Check the coupler for any pins that may be pulled out. • Check the locking condition of the coupler. • If there is a malfunction, repair it and connect the coupler securely. 	
3	Open or short circuit in wire harness.	<ul style="list-style-type: none"> • Repair or replace if there is an open or short circuit. • Between throttle position sensor coupler and ECU coupler. (black/brown–black/brown) (white–white) (black–black) (blue/green–blue/green) 	
4	Defective throttle position sensor.	<ul style="list-style-type: none"> • Execute the diagnostic mode. (Code No. D:01 and/or D:13) • Replace if defective. Refer to “CHECKING THE THROTTLE POSITION SENSOR” on page 8-137.	
Reinstatement method		Turning the main switch to “ON”.	

Fault code No.		17	
Item		EXUP servo motor circuit: open or short circuit detected.	
Fail-safe system		Able to start engine	
		Able to drive vehicle	
Diagnostic code No.		D:53	
Actuator operation		Actuates the EXUP servo motor (turns to open side and to closed side). Illuminates the engine trouble warning light.	
Checking method		Check the operating sound.	
Probable cause of malfunction		Check or maintenance job	
1	Connections <ul style="list-style-type: none"> • EXUP servo motor coupler • Wire harness ECU coupler 	<ul style="list-style-type: none"> • Check the coupler for any pins that may be pulled out. • Check the locking condition of the couplers. • If there is a malfunction, repair it and connect the coupler securely. 	

FUEL INJECTION SYSTEM

Fault code No.		17
Item		EXUP servo motor circuit: open or short circuit detected.
2	Open or short circuit in wire harness.	<ul style="list-style-type: none"> • Repair or replace if there is an open or short circuit. • Between EXUP servo motor coupler and ECU coupler. (blue–blue) (white/red–white/red) (black/blue–black/blue)
3	Defective EXUP servo motor (potentiometer circuit).	<ul style="list-style-type: none"> • Execute the diagnostic mode. (Code No. D:53) • Replace if defective.
Reinstatement method		Reinstated automatically if a normal signal is received.

Fault code No.		18
Item		EXUP servo motor: stuck EXUP servo motor is detected.
Fail-safe system		Able to start engine
		Able to drive vehicle
Diagnostic code No.		D:53
Actuator operation		Actuates the EXUP servo motor (turns to open side and to closed side). Illuminates the engine trouble warning light.
Checking method		Check the operating sound.
Probable cause of malfunction		Check or maintenance job
1	Connections <ul style="list-style-type: none"> • EXUP servo motor coupler • Wire harness ECU coupler 	<ul style="list-style-type: none"> • Check the coupler for any pins that may be pulled out. • Check the locking condition of the couplers. • If there is a malfunction, repair it and connect the coupler securely.
2	Open or short circuit in wire harness.	<ul style="list-style-type: none"> • Repair or replace if there is an open or short circuit. • Between EXUP servo motor coupler and ECU coupler. (black/white–black/white) (black/red–black/red)
3	Defective EXUP servo motor.	<ul style="list-style-type: none"> • Execute the diagnostic mode. (Code No. D:53) • Replace if defective.
4	Defective EXUP valve, pulley, and cables.	<ul style="list-style-type: none"> • Replace if defective.
Reinstatement method		Turning the main switch to “ON”. It takes 3 seconds at the maximum before the original state returns.

FUEL INJECTION SYSTEM

Fault code No.	19	
Item	Sidestand switch: a break or disconnection of the blue/yellow lead of the ECU is detected.	
Fail-safe system	Unable to start engine	
	Unable to drive vehicle	
Diagnostic code No.	D:20	
Meter display	Sidestand switch • ON (stand retracted) • OFF (stand extended)	
Checking method	Set on/off the sidestand switch. (with the transmission in gear.)	
	Probable cause of malfunction	Check or maintenance job
1	Connections • Wire harness ECU coupler	<ul style="list-style-type: none"> • Check the coupler for any pins that may be pulled out. • Check the locking condition of the coupler. • If there is a malfunction, repair it and connect the coupler securely.
2	Open or short circuit in wire harness.	<ul style="list-style-type: none"> • Repair or replace if there is an open or short circuit. • Between ECU and blue/yellow lead.
3	Defective sidestand switch.	<ul style="list-style-type: none"> • Execute the diagnostic mode. (Code No. D:20) • Replace if defective. Refer to "CHECKING THE SWITCHES" on page 8-121.
Reinstatement method	If the transmission is in gear, retracting the sidestand. If the transmission is in neutral, reconnecting the wiring.	

Fault code No.	20	
Item	Intake air pressure sensor or atmospheric pressure sensor: when the main switch is turned to "ON", the atmospheric pressure sensor voltage and intake air pressure sensor voltage differ greatly.	
Fail-safe system	Able to start engine	
	Able to drive vehicle	
Diagnostic code No.	D:03, D:02	
D:03	Meter display	Displays the intake air pressure.
	Checking method	Set the engine stop switch to "○", and then push the start switch "⊗". (If the display value changes, the performance is OK.)
D:02	Meter display	Displays the atmospheric pressure.
	Checking method	Compare the actually measured atmospheric pressure with the meter display value.
	Probable cause of malfunction	Check or maintenance job

FUEL INJECTION SYSTEM

Fault code No.	20	
Item	Intake air pressure sensor or atmospheric pressure sensor: when the main switch is turned to "ON", the atmospheric pressure sensor voltage and intake air pressure sensor voltage differ greatly.	
1	Defective intake air pressure sensor or atmospheric pressure sensor.	<ul style="list-style-type: none"> • Execute the diagnostic mode. (Code No. D:03 and/or D:02) • Replace if defective. Refer to "CHECKING THE INTAKE AIR PRESSURE SENSOR" on page 8-139 or "CHECKING THE ATMOSPHERIC PRESSURE SENSOR" on page 8-138.
Reinstatement method	Turning the main switch to "ON".	

Fault code No.	21	
Item	Coolant temperature sensor: open or short circuit detected.	
Fail-safe system	Able to start engine	
	Able to drive vehicle	
Diagnostic code No.	D:06	
Meter display	Displays the coolant temperature.	
Checking method	Compare the actually measured coolant temperature with the meter display value.	
	Probable cause of malfunction	Check or maintenance job
1	Installed condition of coolant temperature sensor.	<ul style="list-style-type: none"> • Check for looseness or pinching.
2	Connections <ul style="list-style-type: none"> • Coolant temperature sensor coupler • Wire harness ECU coupler • Sub-wire harness coupler 	<ul style="list-style-type: none"> • Check the coupler for any pins that may be pulled out. • Check the locking condition of the coupler. • If there is a malfunction, repair it and connect the coupler securely.
3	Open or short circuit in wire harness and/or sub-wire harness.	<ul style="list-style-type: none"> • Repair or replace if there is an open or short circuit. • Between coolant temperature sensor coupler and sub-wire harness coupler. (black/blue–black/blue) (green/orange–green/orange) • Between sub-wire harness coupler and ECU coupler. (black/blue–black/blue) (green/white–green/white)
4	Defective coolant temperature sensor.	<ul style="list-style-type: none"> • Execute the diagnostic mode. (Code No. D:06) • Replace if defective. Refer to "CHECKING THE COOLANT TEMPERATURE SENSOR" on page 8-136.
Reinstatement method	Turning the main switch to "ON".	

FUEL INJECTION SYSTEM

Fault code No.	22	
Item	Intake air temperature sensor: open or short circuit detected.	
Fail-safe system	Able to start engine	
	Able to drive vehicle	
Diagnostic code No.	D:05	
Meter display	Displays the intake air temperature.	
Checking method	Compare the actually measured intake air temperature with the meter display value.	
Probable cause of malfunction		Check or maintenance job
1	Installed condition of intake air temperature sensor.	<ul style="list-style-type: none"> • Check for looseness or pinching.
2	Connections <ul style="list-style-type: none"> • Intake air temperature sensor coupler • Wire harness ECU coupler 	<ul style="list-style-type: none"> • Check the coupler for any pins that may be pulled out. • Check the locking condition of the coupler. • If there is a malfunction, repair it and connect the coupler securely.
3	Open or short circuit in wire harness.	<ul style="list-style-type: none"> • Repair or replace if there is an open or short circuit. • Between intake air temperature sensor coupler and ECU coupler. (black/blue–black/blue) (brown/white–brown/white)
4	Defective intake air temperature sensor.	<ul style="list-style-type: none"> • Execute the diagnostic mode. (Code No. D:05) • Replace if defective. Refer to “CHECKING THE INTAKE AIR TEMPERATURE SENSOR” on page 8-140.
Reinstatement method	Turning the main switch to “ON”.	

Fault code No.	23	
Item	Atmospheric pressure sensor: open or short circuit detected.	
Fail-safe system	Able to start engine	
	Able to drive vehicle	
Diagnostic code No.	D:02	
Meter display	Displays the atmospheric pressure.	
Checking method	Compare the actually measured atmospheric pressure with the meter display value.	
Probable cause of malfunction		Check or maintenance job
1	Installed condition of atmospheric pressure sensor.	<ul style="list-style-type: none"> • Check for looseness or pinching.
2	Connections <ul style="list-style-type: none"> • Atmospheric pressure sensor coupler • Wire harness ECU coupler 	<ul style="list-style-type: none"> • Check the coupler for any pins that may be pulled out. • Check the locking condition of the coupler. • If there is a malfunction, repair it and connect the coupler securely.

FUEL INJECTION SYSTEM

Fault code No.	23	
Item	Atmospheric pressure sensor: open or short circuit detected.	
3	Open or short circuit in wire harness.	<ul style="list-style-type: none"> • Repair or replace if there is an open or short circuit. • Between atmospheric pressure sensor coupler and ECU coupler. (blue–blue) (pink–pink) (black/blue–black/blue)
4	Defective atmospheric pressure sensor.	<ul style="list-style-type: none"> • Execute the diagnostic mode. (Code No. D:02) • Replace if defective. Refer to “CHECKING THE ATMOSPHERIC PRESSURE SENSOR” on page 8-138.
Reinstatement method	Reinstated automatically if a normal signal is received.	

Fault code No.	24	
Item	O₂ sensor: no normal signal is received from the O₂ sensor.	
Fail-safe system	Able to start engine	
	Able to drive vehicle	
Diagnostic code No.	—	
Meter display	—	
Checking method	—	
Probable cause of malfunction		Check or maintenance job
1	Installed condition of O ₂ sensor.	<ul style="list-style-type: none"> • Check for looseness or pinching.
2	Connections <ul style="list-style-type: none"> • O₂ sensor coupler • Wire harness ECU coupler 	<ul style="list-style-type: none"> • Check the coupler for any pins that may be pulled out. • Check the locking condition of the coupler. • If there is a malfunction, repair it and connect the coupler securely.
3	Open or short circuit in wire harness.	<ul style="list-style-type: none"> • Repair or replace if there is an open or short circuit. • Between O₂ sensor coupler and ECU coupler. (black/blue–black/blue) (gray/black–gray/black) (pink/black–pink/black) (red/white–red/white)
4	Check fuel pressure.	<ul style="list-style-type: none"> • Refer to “CHECKING THE FUEL PRESSURE” on page 7-4.
5	Defective O ₂ sensor.	<ul style="list-style-type: none"> • Execute the diagnostic mode. (Code No. D:63) • Replace if defective.
Reinstatement method	Starting the engine, warming it up until the coolant temperature is 60 °C (140 °F) or more, and then running it between 2000–3000 r/min until the engine trouble warning light turns off.	

FUEL INJECTION SYSTEM

Fault code No.	30	
Item	Latch up detected. No normal signal is received from the lean angle sensor.	
Fail-safe system	Unable to start engine	
	Unable to drive vehicle	
Diagnostic code No.	D:08	
Meter display	Lean angle sensor • 0.4–1.4 (upright) • 3.8–4.2 (overturned)	
Checking method	Remove the lean angle sensor and incline it more than 65 degrees.	
Probable cause of malfunction		Check or maintenance job
1	The vehicle has overturned.	• Raise the vehicle upright.
2	Installed condition of lean angle sensor.	• Check the installed direction and condition of the sensor.
3	Connections • Lean angle sensor coupler • Wire harness ECU coupler	• Check the coupler for any pins that may be pulled out. • Check the locking condition of the coupler. • If there is a malfunction, repair it and connect the coupler securely.
4	Defective lean angle sensor.	• Execute the diagnostic mode. (Code No. D:08) • Replace if defective. Refer to “CHECKING THE LEAN ANGLE SENSOR” on page 8-133.
Reinstatement method	Turning the main switch to “ON” (however, the engine cannot be restarted unless the main switch is first turned “OFF”).	

Fault code No.	33	
Item	Cylinder-#1 ignition coil: open or short circuit detected in the primary lead of the cylinder-#1 ignition coil.	
Fail-safe system	Able to start engine (depending on the number of faulty cylinders)	
	Able to drive vehicle (depending on the number of faulty cylinders)	
Diagnostic code No.	D:30	
Actuator operation	Actuates the cylinder-#1 ignition coil five times at one-second intervals. Illuminates the engine trouble warning light.	
Checking method	Check the spark five times. • Connect an ignition checker.	
Probable cause of malfunction		Check or maintenance job
1	Connections • Cylinder-#1 ignition coil coupler • Wire harness ECU coupler • Ignition coil sub-wire harness 1 coupler • Right handlebar switch coupler	• Check the coupler for any pins that may be pulled out. • Check the locking condition of the coupler. • If there is a malfunction, repair it and connect the coupler securely.

FUEL INJECTION SYSTEM

Fault code No.		33
Item		Cylinder-#1 ignition coil: open or short circuit detected in the primary lead of the cylinder-#1 ignition coil.
2	Open or short circuit in wire harness and/or ignition coil sub-wire harness 1.	<ul style="list-style-type: none"> • Repair or replace if there is an open or short circuit. • Between cylinder-#1 ignition coil coupler and ignition coil sub-wire harness 1 coupler. (black/orange–black/orange) (white–white) • Between ignition coil sub-wire harness 1 coupler and ECU coupler. (orange–orange) • Between ignition coil sub-wire harness 1 coupler and right handlebar switch coupler. (red/blue–red/blue)
3	Defective cylinder-#1 ignition coil.	<ul style="list-style-type: none"> • Execute the diagnostic mode. (Code No. D:30) • Test the primary and secondary coils for continuity. • Replace if defective. Refer to “CHECKING THE IGNITION COILS” on page 8-131.
Reinstatement method		Starting the engine and operating it at idle.

Fault code No.		34
Item		Cylinder-#2 ignition coil: open or short circuit detected in the primary lead of the cylinder-#2 ignition coil.
Fail-safe system		<p>Able to start engine (depending on the number of faulty cylinders)</p> <p>Able to drive vehicle (depending on the number of faulty cylinders)</p>
Diagnostic code No.		D:31
Actuator operation		<p>Actuates the cylinder-#2 ignition coil five times at one-second intervals.</p> <p>Illuminates the engine trouble warning light.</p>
Checking method		<p>Check the spark five times.</p> <ul style="list-style-type: none"> • Connect an ignition checker.
Probable cause of malfunction		Check or maintenance job
1	<p>Connections</p> <ul style="list-style-type: none"> • Cylinder-#2 ignition coil coupler • Wire harness ECU coupler • Ignition coil sub-wire harness 2 coupler • Right handlebar switch coupler 	<ul style="list-style-type: none"> • Check the coupler for any pins that may be pulled out. • Check the locking condition of the coupler. • If there is a malfunction, repair it and connect the coupler securely.

FUEL INJECTION SYSTEM

Fault code No.		34
Item		Cylinder-#2 ignition coil: open or short circuit detected in the primary lead of the cylinder-#2 ignition coil.
2	Open or short circuit in wire harness and/or ignition coil sub-wire harness 2.	<ul style="list-style-type: none"> • Repair or replace if there is an open or short circuit. • Between cylinder-#2 ignition coil coupler and ignition coil sub-wire harness 2 coupler. (black/orange–black/orange) (white–white) • Between ignition coil sub-wire harness 2 coupler and ECU coupler. (gray/red–gray/red) • Between ignition coil sub-wire harness 2 coupler and right handlebar switch coupler. (red/blue–red/blue)
3	Defective cylinder-#2 ignition coil.	<ul style="list-style-type: none"> • Execute the diagnostic mode. (Code No. D:31) • Test the primary and secondary coils for continuity. • Replace if defective. Refer to “CHECKING THE IGNITION COILS” on page 8-131.
Reinstatement method		Starting the engine and operating it at idle.

Fault code No.		35
Item		Cylinder-#3 ignition coil: open or short circuit detected in the primary lead of the cylinder-#3 ignition coil.
Fail-safe system		<p>Able to start engine (depending on the number of faulty cylinders)</p> <p>Able to drive vehicle (depending on the number of faulty cylinders)</p>
Diagnostic code No.		D:32
Actuator operation		<p>Actuates the cylinder-#3 ignition coil five times at one-second intervals.</p> <p>Illuminates the engine trouble warning light.</p>
Checking method		<p>Check the spark five times.</p> <ul style="list-style-type: none"> • Connect an ignition checker.
Probable cause of malfunction		Check or maintenance job
1	<p>Connections</p> <ul style="list-style-type: none"> • Cylinder-#3 ignition coil coupler • Wire harness ECU coupler • Ignition coil sub-wire harness 1 coupler • Right handlebar switch coupler 	<ul style="list-style-type: none"> • Check the coupler for any pins that may be pulled out. • Check the locking condition of the coupler. • If there is a malfunction, repair it and connect the coupler securely.

FUEL INJECTION SYSTEM

Fault code No.		35
Item		Cylinder-#3 ignition coil: open or short circuit detected in the primary lead of the cylinder-#3 ignition coil.
2	Open or short circuit in wire harness and/or ignition coil sub-wire harness 1.	<ul style="list-style-type: none"> • Repair or replace if there is an open or short circuit. • Between cylinder-#3 ignition coil coupler and ignition coil sub-wire harness 1 coupler. (black/orange–black/orange) (black–black) • Between ignition coil sub-wire harness 1 coupler and ECU coupler. (orange/green–orange/green) • Between ignition coil sub-wire harness 1 coupler and right handlebar switch coupler. (red/blue–red/blue)
3	Defective cylinder-#3 ignition coil.	<ul style="list-style-type: none"> • Execute the diagnostic mode. (Code No. D:32) • Test the primary and secondary coils for continuity. • Replace if defective. Refer to “CHECKING THE IGNITION COILS” on page 8-131.
Reinstatement method		Starting the engine and operating it at idle.

Fault code No.		36
Item		Cylinder-#4 ignition coil: open or short circuit detected in the primary lead of the cylinder-#4 ignition coil.
Fail-safe system		<p>Able to start engine (depending on the number of faulty cylinders)</p> <p>Able to drive vehicle (depending on the number of faulty cylinders)</p>
Diagnostic code No.		D:33
Actuator operation		<p>Actuates the cylinder-#4 ignition coil five times at one-second intervals.</p> <p>Illuminates the engine trouble warning light.</p>
Checking method		<p>Check the spark five times.</p> <ul style="list-style-type: none"> • Connect an ignition checker.
Probable cause of malfunction		Check or maintenance job
1	<p>Connections</p> <ul style="list-style-type: none"> • Cylinder-#4 ignition coil coupler • Wire harness ECU coupler • Ignition coil sub-wire harness 2 coupler • Right handlebar switch coupler 	<ul style="list-style-type: none"> • Check the coupler for any pins that may be pulled out. • Check the locking condition of the coupler. • If there is a malfunction, repair it and connect the coupler securely.

FUEL INJECTION SYSTEM

Fault code No.		36
Item		Cylinder-#4 ignition coil: open or short circuit detected in the primary lead of the cylinder-#4 ignition coil.
2	Open or short circuit in wire harness and/or ignition coil sub-wire harness 2.	<ul style="list-style-type: none"> • Repair or replace if there is an open or short circuit. • Between cylinder-#4 ignition coil coupler and ignition coil sub-wire harness 2 coupler. (black/orange–black/orange) (black–black) • Between ignition coil sub-wire harness 2 coupler and ECU coupler. (gray/green–gray/green) • Between ignition coil sub-wire harness 2 coupler and right handlebar switch coupler. (red/blue–red/blue)
3	Defective cylinder-#4 ignition coil.	<ul style="list-style-type: none"> • Execute the diagnostic mode. (Code No. D:33) • Test the primary and secondary coils for continuity. • Replace if defective. Refer to “CHECKING THE IGNITION COILS” on page 8-131.
Reinstatement method		Starting the engine and operating it at idle.

Fault code No.		39
Item		Injector: open or short circuit detected.
Fail-safe system		Able to start engine (depending on the number of faulty cylinders) Able to drive vehicle (depending on the number of faulty cylinders)
Diagnostic code No.		D:36, D:37, D:38, D:39
D:36	Actuator operation	Actuates the injector #1 five times at one-second intervals. Illuminates the engine trouble warning light.
	Checking method	Check the operating sound of the injector #1 five times.
D:37	Actuator operation	Actuates the injector #2 five times at one-second intervals. Illuminates the engine trouble warning light.
	Checking method	Check the operating sound of the injector #2 five times.
D:38	Actuator operation	Actuates the injector #3 five times at one-second intervals. Illuminates the engine trouble warning light.
	Checking method	Check the operating sound of the injector #3 five times.
D:39	Actuator operation	Actuates the injector #4 five times at one-second intervals. Illuminates the engine trouble warning light.
	Checking method	Check the operating sound of the injector #4 five times.
Probable cause of malfunction		Check or maintenance job
1	Connections <ul style="list-style-type: none"> • Injector coupler • Wire harness ECU coupler • Sub-wire harness coupler 	<ul style="list-style-type: none"> • Check the couplers for any pins that may be pulled out. • Check the locking condition of the couplers. • If there is a malfunction, repair it and connect the coupler securely.

FUEL INJECTION SYSTEM

Fault code No.		39
Item		Injector: open or short circuit detected.
2	Open or short circuit in wire harness and/or sub-wire harness.	<ul style="list-style-type: none"> • Repair or replace if there is an open or short circuit. • Between injector coupler and sub-wire harness coupler. (red-red) #1: (red/yellow-red/yellow) #2: (green-green) #3: (blue/black-blue/black) #4: (orange-orange) • Between sub-wire harness coupler and ECU coupler. (red-red/blue) #1: (red/black-red/black) #2: (green/red-green/red) #3: (blue/black-blue/black) #4: (orange/black-orange/black)
3	Defective injector.	<ul style="list-style-type: none"> • Execute the diagnostic mode. (Code No. D:36, D:37, D:38, and/or D:39) • Replace if defective. Refer to "CHECKING THE INJECTORS" on page 7-14.
Reinstatement method		Cranking the engine. (Connect the fuel injector couplers.)

Fault code No.		41
Item		Lean angle sensor: open or short circuit detected.
Fail-safe system	Unable to start engine	
	Unable to drive vehicle	
Diagnostic code No.	D:08	
Meter display	Lean angle sensor <ul style="list-style-type: none"> • 0.4-1.4 (upright) • 3.8-4.2 (overturned) 	
Checking method	Remove the lean angle sensor and incline it more than 65 degrees.	

FUEL INJECTION SYSTEM

Fault code No.	41	
Item	Lean angle sensor: open or short circuit detected.	
	Probable cause of malfunction	Check or maintenance job
1	Connections <ul style="list-style-type: none"> • Lean angle sensor coupler • Wire harness ECU coupler 	<ul style="list-style-type: none"> • Check the coupler for any pins that may be pulled out. • Check the locking condition of the coupler. • If there is a malfunction, repair it and connect the coupler securely.
2	Open or short circuit in wire harness.	<ul style="list-style-type: none"> • Repair or replace if there is an open or short circuit. • Between lean angle sensor coupler and ECU coupler. (black/blue–black/blue) (yellow/green–yellow/green) (blue–blue) (blue/green–blue/green)
3	Defective lean angle sensor.	<ul style="list-style-type: none"> • Execute the diagnostic mode. (Code No. D:08) • Replace if defective. Refer to “CHECKING THE LEAN ANGLE SENSOR” on page 8-133.
Reinstatement method	Turning the main switch to “ON”.	

FUEL INJECTION SYSTEM

Fault code No.		42	
Item	A	Rear wheel sensor: no normal signals are received from the rear wheel sensor.	
	B	Gear position switch: open or short circuit is detected in the neutral circuit of the gear position switch.	
Fail-safe system	Able to start engine		
	Able to drive vehicle		
Diagnostic code No.		D:07	
Meter display		0-999	
Checking method		Check that the number increases when the rear wheel is rotated. The number is cumulative and does not reset each time the wheel is stopped.	
		Probable cause of malfunction	Check or maintenance job
A	1	Connections <ul style="list-style-type: none"> • Rear wheel sensor coupler • Wire harness ECU coupler • ABS ECU coupler 	<ul style="list-style-type: none"> • Check the coupler for any pins that may be pulled out. • Check the locking condition of the coupler. • If there is a malfunction, repair it and connect the coupler securely.
	2	Open or short circuit in wire harness.	<ul style="list-style-type: none"> • Repair or replace if there is an open or short circuit. • Between rear wheel sensor coupler and ABS ECU coupler. (white-white) (black-black) • Between ABS ECU coupler and ECU coupler. (white/yellow-white/yellow)
	3	Sensor rotor for detecting vehicle speed has broken.	<ul style="list-style-type: none"> • Replace the rear wheel. Refer to "REAR WHEEL" on page 4-20.
	4	Defective rear wheel sensor.	<ul style="list-style-type: none"> • Execute the diagnostic mode. (Code No. D:07) • Replace if defective. Refer to "MAINTENANCE OF THE REAR WHEEL SENSOR AND SENSOR ROTOR" on page 4-24.
Reinstatement method		Starting the engine, and inputting the vehicle speed signals by operating the vehicle at a 20 to 30 km/h.	

FUEL INJECTION SYSTEM

Fault code No.		42	
Item		A	Rear wheel sensor: no normal signals are received from the rear wheel sensor.
		B	Gear position switch: open or short circuit is detected in the neutral circuit of the gear position switch.
Fail-safe system	Able to start engine		
	Able to drive vehicle		
Diagnostic code No.		D:21	
Meter display		Gear position switch • ON (neutral) • OFF (in gear)	
Checking method		Shift the transmission.	
		Probable cause of malfunction	Check or maintenance job
B	1	Connections • Gear position switch coupler • Wire harness ECU coupler • Relay unit coupler	<ul style="list-style-type: none"> • Check the coupler for any pins that may be pulled out. • Check the locking condition of the coupler. • If there is a malfunction, repair it and connect the coupler securely.
	2	Open or short circuit in wire harness.	<ul style="list-style-type: none"> • Repair or replace if there is an open or short circuit. • Between gear position switch coupler and relay unit coupler. (sky blue–sky blue) • Between relay unit coupler and ECU coupler. (black/yellow–black/yellow)
	3	Faulty shift drum (neutral detection area).	<ul style="list-style-type: none"> • Replace if defective. Refer to “TRANSMISSION” on page 5-98.
	4	Defective gear position switch (neutral circuit).	<ul style="list-style-type: none"> • Execute the diagnostic mode. (Code No. D:21) • Replace if defective. Refer to “CHECKING THE SWITCHES” on page 8-121.
	Reinstatement method		Starting the engine, and inputting the vehicle speed signals by operating the vehicle at a 20 to 30 km/h.

Fault code No.		43	
Item		Fuel system voltage: the ECU is unable to monitor the battery voltage (an open or short circuit in the line to the ECU).	
Fail-safe system		Able to start engine	
		Able to drive vehicle	
Diagnostic code No.		D:09	
Meter display		Approximately 12.0	
Checking method		Set the engine stop switch to “○”, and then compare with the actually measured battery voltage. (If the battery voltage is lower, perform recharging.)	

FUEL INJECTION SYSTEM

Fault code No.	43	
Item	Fuel system voltage: the ECU is unable to monitor the battery voltage (an open or short circuit in the line to the ECU).	
	Probable cause of malfunction	Check or maintenance job
1	Connections <ul style="list-style-type: none"> • Relay unit coupler • Wire harness ECU coupler • Right handlebar switch coupler • Battery terminal 	<ul style="list-style-type: none"> • Check the coupler for any pins that may be pulled out. • Check the locking condition of the coupler. • If there is a malfunction, repair it and connect the coupler securely.
2	Open or short circuit in the wire harness.	<ul style="list-style-type: none"> • Repair or replace if there is an open or short circuit. • Between relay unit coupler and ECU coupler. (blue/red–blue/red) (red/blue–red/blue) • Between relay unit coupler and right handlebar switch coupler. (red/blue–red/blue) • Between relay unit coupler and battery terminal. (brown/white–red)
3	Malfunction or open circuit in fuel pump relay.	<ul style="list-style-type: none"> • Execute the diagnostic mode. (Code No. D:09) • Replace if defective. • If there is no malfunction with the fuel pump relay, replace the ECU.
Reinstatement method	Starting the engine and operating it at idle.	

Fault code No.	44	
Item	EEPROM fault cylinder No.: an error is detected while reading or writing on EEPROM (CO adjustment value).	
Fail-safe system	Able/Unable to start engine	
	Able/Unable to drive vehicle	
Diagnostic code No.	D:60	
Meter display	EEPROM fault code display <ul style="list-style-type: none"> • 00 (no history) • 01–04 (Cylinder fault code) (history exists) (If more than one cylinder is defective, the display alternates every two seconds to show all the detected cylinder numbers. When all cylinder numbers are shown, the display repeats the same process.)	
Checking method	—	
	Probable cause of malfunction	Check or maintenance job
1	Malfunction in ECU.	<ul style="list-style-type: none"> • Execute the diagnostic mode (Code No. D:60). <ol style="list-style-type: none"> 1. Check the faulty cylinder number. (If multiple cylinders are defective, the numbers of the faulty cylinders are displayed alternately at 2-second intervals.) • Replace ECU if defective.
Reinstatement method	Turning the main switch to “ON”.	

FUEL INJECTION SYSTEM

Fault code No.	46	
Item	Power supply to the fuel injection system is not normal.	
Fail-safe system	Able to start engine	
	Able to drive vehicle	
Diagnostic code No.	—	
Meter display	—	
Checking method	—	
	Probable cause of malfunction	Check or maintenance job
1	Connections <ul style="list-style-type: none"> • Wire harness ECU coupler • Main switch coupler • Main fuse coupler • Battery terminal 	<ul style="list-style-type: none"> • Check the coupler for any pins that may be pulled out. • Check the locking condition of the coupler. • If there is a malfunction, repair it and connect the coupler securely.
2	Faulty battery.	<ul style="list-style-type: none"> • Replace or charge the battery. Refer to “CHECKING AND CHARGING THE BATTERY” on page 8-126.
3	Malfunction in rectifier/regulator	<ul style="list-style-type: none"> • Replace if defective. Refer to “CHARGING SYSTEM” on page 8-13.
4	Open or short circuit in wire harness.	<ul style="list-style-type: none"> • Repair or replace if there is an open or short circuit. • Between battery terminal and main fuse coupler. (red–red) • Between main fuse coupler and main switch coupler. (red–red) • Between main switch coupler and ECU coupler. (brown–red/white)
Reinstatement method	Starting the engine and operating it at idle.	

Fault code No.	50	
Item	Faulty ECU memory. (When this malfunction is detected in the ECU, the fault code number might not appear on the meter.)	
Fail-safe system	Unable to start engine	
	Unable to drive vehicle	
Diagnostic code No.	—	
Meter display	—	
Checking method	—	

FUEL INJECTION SYSTEM

Fault code No.	50	
Item	Faulty ECU memory. (When this malfunction is detected in the ECU, the fault code number might not appear on the meter.)	
	Probable cause of malfunction	Check or maintenance job
1	Malfunction in ECU.	<ul style="list-style-type: none"> • Replace the ECU. TIP _____ Do not perform this procedure with the main switch turned to "ON".
Reinstatement method	Turning the main switch to "ON".	

Fault code No.	59	
Item	Accelerator position sensor: open or short circuit detected.	
Fail-safe system	Able/Unable to start engine	
	Able/Unable to drive vehicle	
Diagnostic code No.	D:14, D:15	
D:14	Meter display	Accelerator position sensor signal 1 <ul style="list-style-type: none"> • 15–16 (fully closed position) • 97–102 (fully opened position)
	Checking method	<ul style="list-style-type: none"> • Check with throttle grip fully closed. • Check with throttle grip fully open.
D:15	Meter display	Accelerator position sensor signal 2 <ul style="list-style-type: none"> • 15–16 (fully closed position) • 97–102 (fully opened position)
	Checking method	<ul style="list-style-type: none"> • Check with throttle grip fully closed. • Check with throttle grip fully open.
	Probable cause of malfunction	Check or maintenance job
1	Installed condition of accelerator position sensor.	<ul style="list-style-type: none"> • Check for looseness or pinching. • Check that the sensor is installed in the specified position.
2	Connections <ul style="list-style-type: none"> • Accelerator position sensor coupler • Wire harness ECU coupler 	<ul style="list-style-type: none"> • Check the coupler for any pins that may be pulled out. • Check the locking condition of the coupler. • If there is a malfunction, repair it and connect the coupler securely.
3	Open or short circuit in wire harness.	<ul style="list-style-type: none"> • Repair or replace if there is an open or short circuit. • Between accelerator position sensor coupler and ECU coupler. (blue/green–blue/green) (white–white) (black–black) (black/brown–black/brown)

FUEL INJECTION SYSTEM

Fault code No.	59	
Item	Accelerator position sensor: open or short circuit detected.	
4	Defective accelerator position sensor.	<ul style="list-style-type: none"> • Execute the diagnostic mode. (Code No. D:14 and/or D:15) • Replace if defective. Refer to "CHECKING THE ACCELERATOR POSITION SENSOR" on page 8-138.
Reinstatement method	Turning the main switch to "ON".	

Fault code No.	60	
Item	Throttle servo motor: open or short circuit detected. Defective throttle servo motor. Malfunction in ECU (servo motor driving system).	
Fail-safe system	Able/Unable to start engine	
	Able/Unable to drive vehicle	
Diagnostic code No.	D:01, D:13	
D:01	Meter display	Throttle position sensor signal 1 • 15–16 (fully closed position) • 97–102 (fully opened position)
	Checking method	<ul style="list-style-type: none"> • Check with throttle valve fully closed. • Check with throttle valve fully open.
D:13	Meter display	Throttle position sensor signal 2 • 15–16 (fully closed position) • 97–102 (fully opened position)
	Checking method	<ul style="list-style-type: none"> • Check with throttle valve fully closed. • Check with throttle valve fully open.
Probable cause of malfunction		Check or maintenance job
1	Installed condition of throttle position sensor.	<ul style="list-style-type: none"> • Check for looseness or pinching. • Check that the sensor is installed in the specified position.
2	Connections • Throttle servo motor coupler • Wire harness ECU coupler	<ul style="list-style-type: none"> • Check the coupler for any pins that may be pulled out. • Check the locking condition of the coupler. • If there is a malfunction, repair it and connect the coupler securely.
3	Open or short circuit in wire harness.	<ul style="list-style-type: none"> • Repair or replace if there is an open or short circuit. • Between throttle servo motor coupler and ECU coupler. (yellow/red–yellow/red) (yellow/white–yellow/white)
4	Defective throttle servo motor.	<ul style="list-style-type: none"> • Execute the diagnostic mode. (Code No. D:01 and/or D:13) • Replace the throttle body assembly if defective.
5	Malfunction in ECU.	<ul style="list-style-type: none"> • Replace the ECU.

FUEL INJECTION SYSTEM

Fault code No.	60
Item	Throttle servo motor: open or short circuit detected. Defective throttle servo motor. Malfunction in ECU (servo motor driving system).
Reinstatement method	Turning the main switch to "ON".

Fault code No.	70	
Item	Engine idling stop: engine has been left idling. (The ECU automatically stops the engine after 20 minutes if it is left idling.)	
Fail-safe system	Able to start engine	
	Able to drive vehicle	
Diagnostic code No.	—	
Meter display	—	
Checking method	—	
Probable cause of malfunction		Check or maintenance job
1	—	—
Reinstatement method	—	

Fault code No.	ER-1	
Item	ECU internal malfunction (output signal error): no signals are received from the ECU.	
Fail-safe system	Able/Unable to start engine	
	Able/Unable to drive vehicle	
Diagnostic code No.	—	
Meter display	—	
Checking method	—	
Probable cause of malfunction		Check or maintenance job
1	Connections <ul style="list-style-type: none"> • Meter assembly 2 coupler • Wire harness ECU coupler 	<ul style="list-style-type: none"> • Check the coupler for any pins that may be pulled out. • Check the locking condition of the coupler. • If there is a malfunction, repair it and connect the coupler securely.
2	Open or short circuit in wire harness.	<ul style="list-style-type: none"> • Repair or replace if there is an open or short circuit. • Between meter assembly 2 coupler and ECU coupler. (yellow/blue–yellow/blue)
3	Malfunction in meter assembly 2.	<ul style="list-style-type: none"> • Replace the meter assembly 2.
4	Malfunction in ECU.	<ul style="list-style-type: none"> • Replace the ECU.
Reinstatement method	Turning the main switch to "ON".	

FUEL INJECTION SYSTEM

Fault code No.	ER-2	
Item	ECU internal malfunction (output signal error): no signals are received from the ECU within the specified duration.	
Fail-safe system	Able to start engine	
	Able to drive vehicle	
Diagnostic code No.	—	
Meter display	—	
Checking method	—	
Probable cause of malfunction		Check or maintenance job
1	Connections <ul style="list-style-type: none"> • Meter assembly 2 coupler • Wire harness ECU coupler 	<ul style="list-style-type: none"> • Check the coupler for any pins that may be pulled out. • Check the locking condition of the coupler. • If there is a malfunction, repair it and connect the coupler securely.
2	Open or short circuit in wire harness.	<ul style="list-style-type: none"> • Repair or replace if there is an open or short circuit. • Between meter assembly 2 coupler and ECU coupler. (yellow/blue–yellow/blue)
3	Malfunction in meter assembly 2.	<ul style="list-style-type: none"> • Replace the meter assembly 2.
4	Malfunction in ECU.	<ul style="list-style-type: none"> • Replace the ECU.
Reinstatement method	Turning the main switch to “ON”.	

Fault code No.	ER-3	
Item	ECU internal malfunction (output signal error): data from the ECU cannot be received correctly.	
Fail-safe system	Able to start engine	
	Able to drive vehicle	
Diagnostic code No.	—	
Meter display	—	
Checking method	—	
Probable cause of malfunction		Check or maintenance job
1	Connections <ul style="list-style-type: none"> • Meter assembly 2 coupler • Wire harness ECU coupler 	<ul style="list-style-type: none"> • Check the coupler for any pins that may be pulled out. • Check the locking condition of the coupler. • If there is a malfunction, repair it and connect the coupler securely.
2	Open or short circuit in wire harness.	<ul style="list-style-type: none"> • Repair or replace if there is an open or short circuit. • Between meter assembly 2 coupler and ECU coupler. (yellow/blue–yellow/blue)
3	Malfunction in meter assembly 2.	<ul style="list-style-type: none"> • Replace the meter assembly 2.

FUEL INJECTION SYSTEM

Fault code No.	ER-3	
Item	ECU internal malfunction (output signal error): data from the ECU cannot be received correctly.	
4	Malfunction in ECU.	• Replace the ECU.
Reinstatement method	Turning the main switch to “ON”.	

Fault code No.	ER-4	
Item	ECU internal malfunction (input signal error): non-registered data has been received from the meter.	
Fail-safe system	Able to start engine	
	Able to drive vehicle	
Diagnostic code No.	—	
Meter display	—	
Checking method	—	
	Probable cause of malfunction	Check or maintenance job
1	Connections <ul style="list-style-type: none"> • Meter assembly 2 coupler • Wire harness ECU coupler 	<ul style="list-style-type: none"> • Check the coupler for any pins that may be pulled out. • Check the locking condition of the coupler. • If there is a malfunction, repair it and connect the coupler securely.
2	Open or short circuit in wire harness.	<ul style="list-style-type: none"> • Repair or replace if there is an open or short circuit. • Between meter assembly 2 coupler and ECU coupler. (yellow/blue–yellow/blue)
3	Malfunction in meter assembly 2.	• Replace the meter assembly 2.
4	Malfunction in ECU.	• Replace the ECU.
Reinstatement method	Turning the main switch to “ON”.	

EAS27550

FUEL PUMP SYSTEM

EAS27560

CIRCUIT DIAGRAM

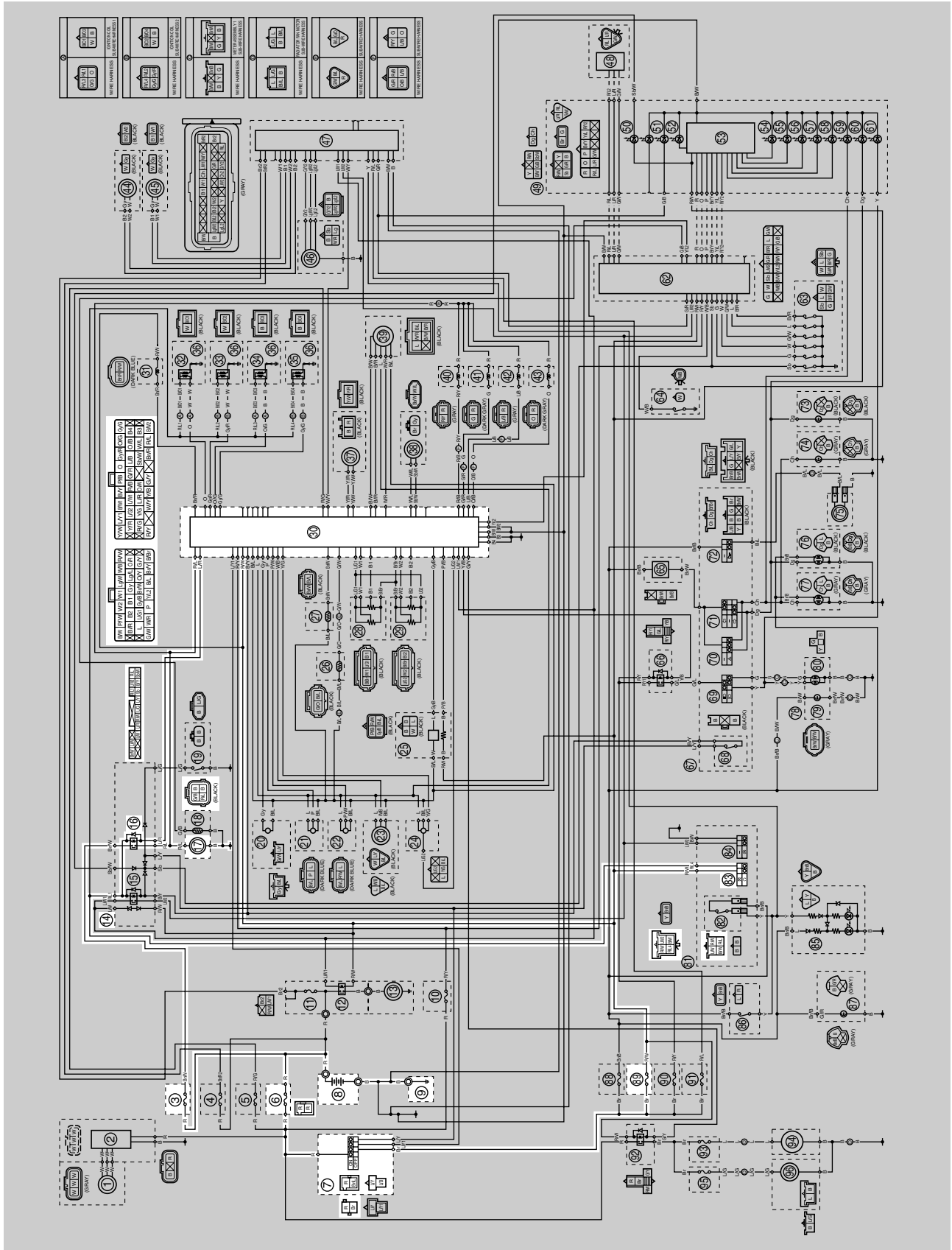

- 3. Fuel injection system fuse
- 6. Main fuse
- 7. Main switch
- 8. Battery
- 9. Frame ground
- 14. Relay unit
- 16. Fuel pump relay
- 17. Fuel pump
- 30. ECU (engine control unit)
- 83. Engine stop switch
- 89. Ignition fuse

EAS27570

TROUBLESHOOTING

If the fuel pump fails to operate.

TIP

• Before troubleshooting, remove the following part(s):

1. Top cover
2. Right side cover
3. Fuel tank

<p>1. Check the fuses. (Main, ignition and fuel injection system) Refer to "CHECKING THE FUSES" on page 8-125.</p>	<p>NG →</p>	<p>Replace the fuse(s).</p>
<p>OK ↓</p>		
<p>2. Check the battery. Refer to "CHECKING AND CHARGING THE BATTERY" on page 8-126.</p>	<p>NG →</p>	<ul style="list-style-type: none"> • Clean the battery terminals. • Recharge or replace the battery.
<p>OK ↓</p>		
<p>3. Check the main switch. Refer to "CHECKING THE SWITCHES" on page 8-121.</p>	<p>NG →</p>	<p>Replace the main switch.</p>
<p>OK ↓</p>		
<p>4. Check the engine stop switch. Refer to "CHECKING THE SWITCHES" on page 8-121.</p>	<p>NG →</p>	<p>Replace the right handlebar switch.</p>
<p>OK ↓</p>		
<p>5. Check the relay unit (fuel pump relay). Refer to "CHECKING THE RELAYS" on page 8-129.</p>	<p>NG →</p>	<p>Replace the relay unit.</p>
<p>OK ↓</p>		
<p>6. Check the fuel pump. Refer to "CHECKING THE FUEL PUMP BODY" on page 7-3.</p>	<p>NG →</p>	<p>Replace the fuel pump assembly.</p>
<p>OK ↓</p>		
<p>7. Check the entire fuel pump system wiring. Refer to "CIRCUIT DIAGRAM" on page 8-69.</p>	<p>NG →</p>	<p>Properly connect or repair the fuel pump system wiring.</p>
<p>OK ↓</p>		
<p>Replace the ECU.</p>		

ABS (ANTI-LOCK BRAKE SYSTEM)

- 4. ABS solenoid fuse
- 6. Main fuse
- 7. Main switch
- 8. Battery
- 9. Frame ground
- 11. ABS motor fuse
- 12. Starter relay
- 14. Relay unit
- 15. Starting circuit cut-off relay
- 30. ECU (engine control unit)
- 44. Rear wheel sensor
- 45. Front wheel sensor
- 46. ABS test coupler
- 47. ABS ECU (electronic control unit)
- 51. ABS warning light
- 53. Multi-function meter
- 62. Meter assembly 2
- 82. Front brake light switch
- 83. Engine stop switch
- 84. Start switch
- 85. Tail/brake light
- 86. Rear brake light switch
- 88. Signaling system fuse
- 89. Ignition fuse
- 91. ABS ECU fuse

ABS (ANTI-LOCK BRAKE SYSTEM)

EAS27740

ABS COMPONENTS CHART

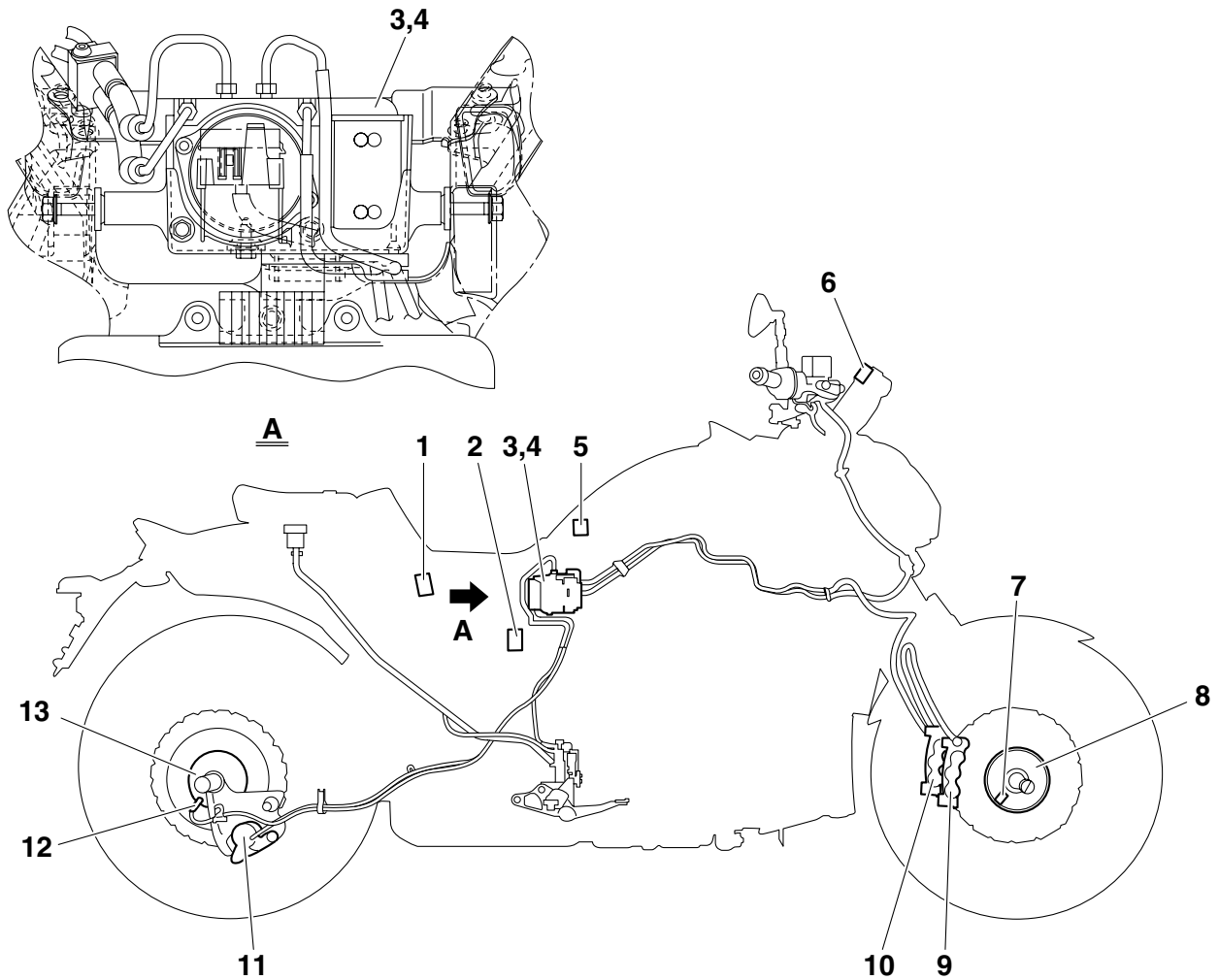

1. ABS ECU fuse
2. ABS test coupler
3. Hydraulic unit assembly
4. ABS solenoid fuse
5. ABS motor fuse
6. ABS warning light
7. Front wheel sensor
8. Front wheel sensor rotor
9. Right front brake caliper
10. Left front brake caliper
11. Rear brake caliper
12. Rear wheel sensor
13. Rear wheel sensor rotor

ABS (ANTI-LOCK BRAKE SYSTEM)

EAS27750

ABS COUPLER LOCATION CHART

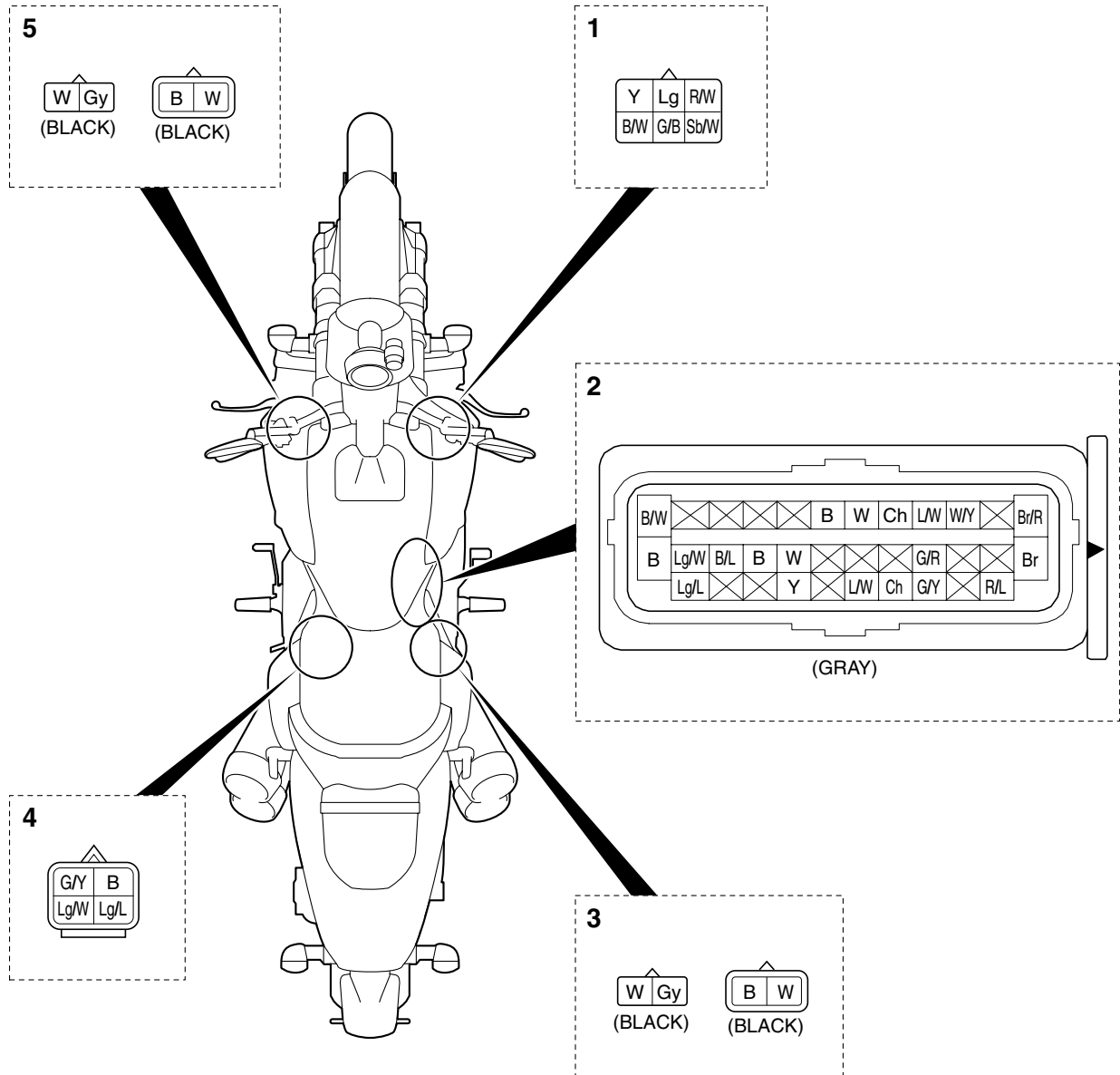

ABS (ANTI-LOCK BRAKE SYSTEM)

1. Meter assembly 1 coupler
2. ABS ECU coupler
3. Rear wheel sensor coupler
4. ABS test coupler
5. Front wheel sensor coupler

ABS (ANTI-LOCK BRAKE SYSTEM)

EAS27770

MAINTENANCE OF THE ABS ECU

Checking the ABS ECU

1. Check:

- Terminals “1” of the ABS ECU
Cracks/damages → Replace the hydraulic unit assembly and the brake hoses that are connected to the assembly as a set.
- Terminals “2” of the ABS ECU coupler
Connection defective, contaminated, come-off → Correct or clean.

TIP

If the ABS ECU coupler is clogged with mud or dirt, clean with compressed air.

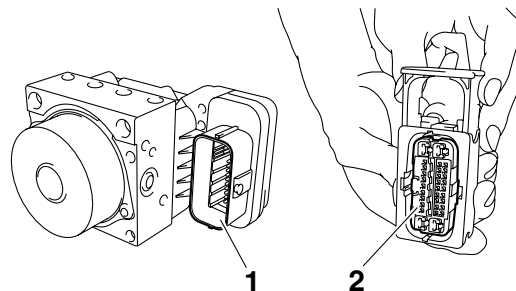

EAS27790

ABS TROUBLESHOOTING OUTLINE

This section describes the troubleshooting for the ABS in detail. Read this service manual carefully and make sure you fully understand the information provided before repairing any malfunctions or performing service.

The ABS ECU (electronic control unit) has a self-diagnosis function. When failures occur in the system, the ABS warning light on the meter assembly 1 indicates a malfunction.

The following troubleshooting describes the problem identification and service method according to the indications by the multi-function display. For troubleshooting items other than the following items, follow the normal service method.

EWA2S31020

WARNING

When maintenance or checks have been performed on components related to the ABS, be sure to perform a final check before delivering the vehicle to the customer. (Refer to “[D-3] FINAL CHECK” on page 8-115.)

ABS operation when the ABS warning light comes on

1. The ABS warning light remains on → ABS operates as a normal brake system.
 - A malfunction was detected using the ABS self-diagnosis function.
2. The ABS warning light comes on, and then goes off when starting the engine → ABS operation is normal.
 - The ABS warning light comes on for 2 seconds, and then goes off every time the main switch is turned to “ON”.
 - The ABS warning light comes on while the start switch is being pushed.
3. The ABS warning light flashes → ABS operation is normal.
 - Refer to “BASIC INSTRUCTIONS FOR TROUBLESHOOTING” on page 8-80.

Self-diagnosis and servicing

The ABS ECU has a self-diagnosis function. By utilizing this function, quick problem identification and service are possible. Previous malfunctions can be checked since the ABS ECU also stores the malfunction history.

The multi-function display indicates all the fault codes recorded in the ABS ECU.

Note all of the indicated fault codes if more than two fault codes are stored in the memory. When the service is finished, check the normal operation of the vehicle, and then delete the fault code(s). (Refer to “[D-3] FINAL CHECK” on page 8-115.) By deleting the fault codes stored in the ABS ECU memory, it is possible to pursue the cause correctly if another malfunction occurs.

TIP

The ABS performs a self-diagnosis test for a few seconds each time the vehicle first starts off after the main switch was turned on. During this test, a “clicking” noise can be heard from under the seat, and if the brake lever or brake pedal are even slightly applied, a vibration can be felt at the lever and pedal, but these do not indicate a malfunction.

Self-diagnosis using the ABS ECU

The ABS ECU performs a static check of the entire system when the main switch is turned to “ON”. It also checks for malfunctions while the vehicle is ridden. Since all malfunctions are recorded after they are detected, it is possible to check the recorded malfunction data by utilizing the multi-function display when the ABS ECU has entered the self-diagnosis mode.

Special precautions for handling and servicing a vehicle equipped with ABS

ECA2S31054

NOTICE

Care should be taken not to damage components by subjecting them to shocks or pulling on them with too much force since the ABS components are precisely adjusted.

- The ABS ECU and hydraulic unit are united assemblies and cannot be disassembled.
- The malfunction history is stored in the memory of the ABS ECU. Delete the fault codes when the service is finished. (This is because the past fault codes will be displayed again if another malfunction occurs.)

EAS27800

BASIC INSTRUCTIONS FOR TROUBLESHOOTING

EWA2S31021

WARNING

- **Perform the troubleshooting [A] → [B] → [C] → [D] in order. Be sure to follow the order since a wrong diagnosis could result if the steps are followed in a different order or omitted.**
- **Use sufficiently charged regular batteries only.**

[A] Malfunction check using the ABS warning light

[B] Detailed check of the malfunction

The results of the self-diagnosis by the ABS ECU can be displayed using the multi-function display.

[C] Determining the cause and location of the malfunction

Determine the cause of the malfunction from the condition and place where the malfunction occurred.

[D] Servicing the ABS

Execute the final check after disassembly and assembly.

ABS (ANTI-LOCK BRAKE SYSTEM)

EAS27810

BASIC PROCESS FOR TROUBLESHOOTING

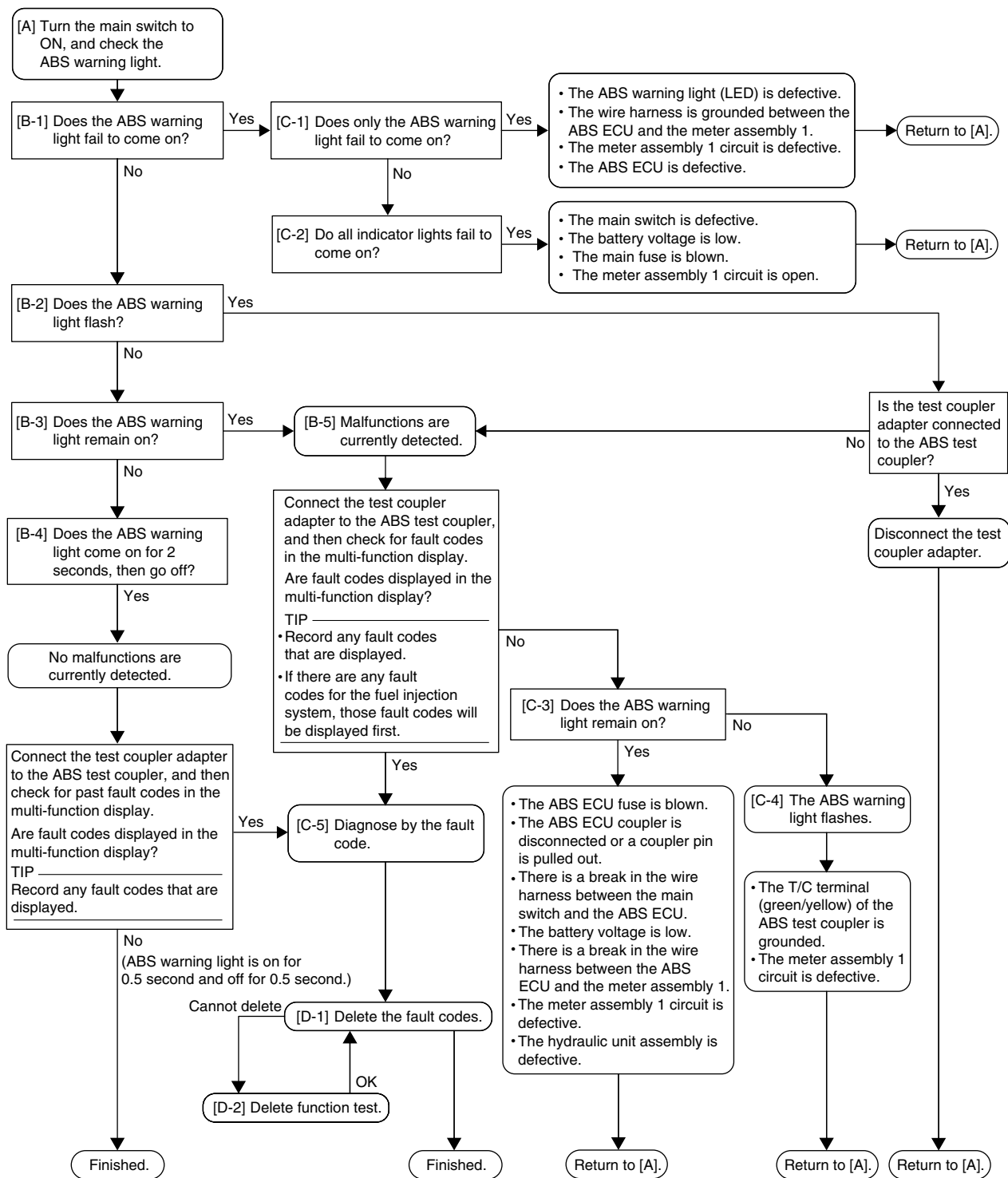

EWA2S31022



When maintenance or checks have been performed on components related to the ABS, be sure to perform a final check before delivering the vehicle to the customer. (Refer to “[D-3] FINAL CHECK” on page 8-115.)

EAS27830

[A] CHECKING THE ABS WARNING LIGHT

Turn the main switch to “ON”. (Do not start the engine.)

1. The ABS warning light does not come on. [B-1]
2. The ABS warning light flashes. [B-2]
3. The ABS warning light remains on. [B-3]
4. The ABS warning light comes on for 2 seconds, then goes off. [B-4]

EAS2S31065

[B-1] THE ABS WARNING LIGHT FAILS TO COME ON

1. Only the ABS warning light fails to come on when the main switch is turned to “ON”. [C-1]
2. The ABS warning light and all other indicator lights fail to come on. [C-2]

EAS2S31066

[B-2] THE ABS WARNING LIGHT FLASHES

1. Test coupler adapter
 - Check if the test coupler adapter is connected to the ABS test coupler.
 - If the test coupler adapter is connected, disconnect it, and then install the protective cap onto the ABS test coupler.
 - If the test coupler adapter is not connected, refer to “[B-5] MALFUNCTION ARE CURRENTLY DETECTED” on page 8-83.

EAS2S31067

[B-3] THE ABS WARNING LIGHT REMAINS ON

1. A malfunction is detected. [B-6]

EAS2S31068

[B-4] THE ABS WARNING LIGHT COMES ON FOR 2 SECONDS, THEN GOES OFF

Remove the left side cover to access the ABS test coupler “1”. Remove the protective cap from the ABS test coupler, and then connect the test coupler adapter “2” to the coupler. The T/C terminal (green/yellow) is now grounded.

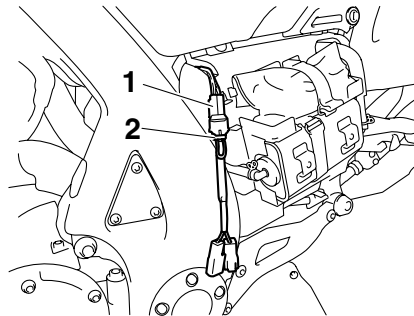

1. The fault code “1” is displayed on the multi-function display (example: fault code ABS-16).

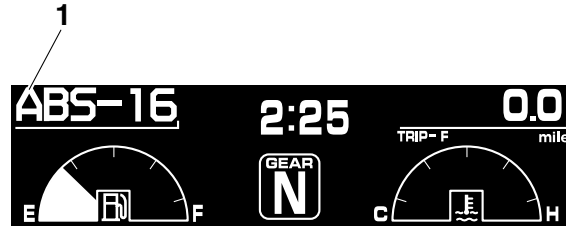

- The ABS warning light flashes every 0.5 second for more than 6 seconds.
The ABS warning light flashes every 0.5 second if a fault code for a past malfunction is not stored in the memory of the ABS ECU. The ABS warning light flashes quicker if a fault code is displayed on the multi-function display. If no fault code is displayed, make sure that the customer understands the possible conditions that may cause the ABS warning light to come on or flash even if the system is normal.

TIP

- The ABS fault codes will not be displayed if a fault code for the fuel injection system is displayed on the multi-function display. To display the ABS fault codes, delete the fuel injection system fault codes, and then start the check again.
- The test coupler adapter must be connected to the ABS test coupler to display the fault codes. If the adapter is not connected, the ABS warning light will come on or flash, but no fault codes will be displayed.

EAS2S31069

[B-5] MALFUNCTION ARE CURRENTLY DETECTED

Remove the left side cover to access the ABS test coupler. Connect the test coupler adapter to the ABS test coupler.

When the test coupler adapter is connected to the ABS test coupler, the fault codes will be displayed in the multi-function display. Record all of the displayed fault codes.

- No fault codes are displayed in the multi-function display and the ABS warning light is on. [C-3]
- No fault codes are displayed in the multi-function display and the ABS warning light is flashing. [C-4]

EAS2S31070

[C-1] ONLY THE ABS WARNING LIGHT FAILS TO COME ON

- Check for a short circuit to the ground between the green/red terminal of the ABS ECU coupler and green/black terminal of the meter assembly 1.
 - If there is no short circuit to the ground, the wire harness is defective. Properly repair or replace the defective harness.
- Disconnect the ABS ECU coupler and check that the ABS warning light comes on when the main switch is turned to "ON".
 - If the ABS warning light does not come on, the meter assembly 1 circuit (including the ABS warning light [LED]) is defective. Replace the meter assembly 1.
 - If the ABS warning light comes on, the ABS ECU is defective. Replace the hydraulic unit assembly.

EAS2S31071

[C-2] ALL INDICATOR LIGHTS FAIL TO COME ON

- Main switch
 - Check the main switch for continuity.
Refer to "CHECKING THE SWITCHES" on page 8-121.
 - If there is no continuity, replace the main switch/immobilizer unit.
- Battery
 - Check the condition of the battery.
Refer to "CHECKING AND CHARGING THE BATTERY" on page 8-126.

ABS (ANTI-LOCK BRAKE SYSTEM)

- If the battery is defective, clean the battery terminals and recharge it, or replace the battery.
3. Main fuse
 - Check the fuse for continuity.
Refer to “CHECKING THE FUSES” on page 8-125.
 - If the main fuse is blown, replace the fuse.
 4. Circuit
 - Check the meter assembly 1 circuit.
Refer to “CIRCUIT DIAGRAM” on page 8-73.
 - If the meter assembly 1 circuit is open, properly repair or replace the wire harness.

EAS2S31072

[C-3] THE ABS WARNING LIGHT REMAINS ON

1. The battery voltage is low.
 - Check the condition of the battery.
Refer to “CHECKING AND CHARGING THE BATTERY” on page 8-126.
 - If the battery voltage is low, clean the battery terminals and recharge it, or replace the battery.
2. ABS ECU fuse
 - Check the ABS ECU fuse for continuity.
Refer to “CHECKING THE FUSES” on page 8-125.
 - If the ABS ECU fuse is blown, replace the fuse.
3. ABS ECU coupler
 - Check that the ABS ECU coupler is connected properly.
 - Connect the couplers properly if necessary.
4. There is a break in the wire harness between the main switch and the ABS ECU or between the ABS ECU and the ground.
 - Check for continuity between the brown terminal of the main switch coupler and brown terminal of the ABS ECU fuse.
 - Check for continuity between the red/blue terminal of the ABS ECU fuse and the red/blue terminal of the ABS ECU coupler.
 - If there is no continuity, the wire harness is defective. Properly repair or replace the wire harness.
 - Check for continuity between the black/white terminal of the ABS ECU coupler and the ground.
 - If there is no continuity, the wire harness is defective. Properly repair or replace the wire harness.
5. There is a break in the wire harness between the ABS ECU and the meter assembly 1 (ABS warning light).
 - Check for continuity between the green/red terminal of the ABS ECU coupler and the green/black terminal of the meter assembly 1 coupler.
 - If there is no continuity, the wire harness is defective. Properly repair or replace the defective harness.
6. The meter assembly 1 circuit is defective.
 - Disconnect the ABS ECU coupler.
 - The green/red terminal of the ABS ECU coupler is short-circuited to the ground.
 - Turn the main switch to “ON”, and then check the ABS warning light.
 - If the ABS warning light is on, the internal circuit of the meter assembly 1 is defective. Replace the meter assembly 1.
 - If the ABS warning light does not come on, the ABS ECU is defective. Replace the hydraulic unit assembly.
7. The hydraulic unit assembly is defective.

EAS2S31073

[C-4] THE ABS WARNING LIGHT FLASHES

1. Check whether the T/C terminal (green/yellow) of the ABS test coupler is short-circuited to the ground when the test coupler adapter is removed.
 - If the T/C terminal is short-circuited to the ground, the wire harness is defective. Properly repair or replace the wire harness.

ABS (ANTI-LOCK BRAKE SYSTEM)

- If the T/C terminal is not short-circuited to the ground, the internal circuit of the meter assembly 1 is defective. Replace the meter assembly 1.

EAS2S31074

[C-5] DIAGNOSIS USING THE FAULT CODES

Connect the test coupler adapter to the ABS test coupler, and then turn the main switch to "ON".

Information for the fault codes from the ABS ECU is contained in the following table. Refer to this table for troubleshooting.

TIP

Record all of the fault codes displayed and inspect the check points.

Fault code table

Fault code No.	Symptom	Check point
ABS-11* ABS-25*	Front wheel sensor signal is not received properly.	<ul style="list-style-type: none"> • Installation of the front wheel sensor • Front wheel • Front wheel sensor housing • Front wheel sensor rotor
ABS-12	Rear wheel sensor signal is not received properly.	<ul style="list-style-type: none"> • Installation of the rear wheel sensor • Rear wheel • Rear wheel sensor housing • Rear wheel sensor rotor
ABS-13 ABS-26	Incorrect signal from the front wheel sensor is detected.	<ul style="list-style-type: none"> • Installation of the front wheel sensor • Front wheel • Front wheel sensor housing • Front wheel sensor rotor • Hydraulic unit assembly
ABS-14 ABS-27	Incorrect signal from the rear wheel sensor is detected.	<ul style="list-style-type: none"> • Installation of the rear wheel sensor • Rear wheel • Rear wheel sensor housing • Rear wheel sensor rotor • Hydraulic unit assembly
ABS-15	No continuity in the front wheel sensor circuit.	<ul style="list-style-type: none"> • Continuity of the front wheel sensor circuit • Wire harness (ABS circuit) • Connection of the front wheel sensor coupler and ABS ECU coupler • Front wheel sensor
ABS-16	No continuity in the rear wheel sensor circuit.	<ul style="list-style-type: none"> • Continuity of the rear wheel sensor circuit • Wire harness (ABS circuit) • Connection of the rear wheel sensor coupler and ABS ECU coupler • Rear wheel sensor
ABS-17 ABS-45	Missing pulses detected in the front wheel sensor signal.	<ul style="list-style-type: none"> • Front wheel sensor rotor • Front wheel sensor housing • Front wheel
ABS-18 ABS-46	Missing pulses detected in the rear wheel sensor signal.	<ul style="list-style-type: none"> • Rear wheel sensor rotor • Rear wheel sensor housing • Rear wheel
ABS-21	Hydraulic unit solenoid circuit is open or short-circuited.	<ul style="list-style-type: none"> • Hydraulic unit assembly

ABS (ANTI-LOCK BRAKE SYSTEM)

Fault code No.	Symptom	Check point
ABS-22	Start switch signal is not received properly (start switch circuit or start switch monitor circuit).	<ul style="list-style-type: none"> • Wire harness • Connection of the relay unit coupler and ABS ECU coupler.
ABS-24	Brake light signal is not received properly while vehicle is traveling (brake light circuit, or front or rear brake light switch circuit).	<ul style="list-style-type: none"> • Wire harness (brake light circuit) • Brake light system couplers and connectors
ABS-31	Solenoid relay is defective. Power is not supplied to the solenoid relay.	<ul style="list-style-type: none"> • ABS solenoid fuse • Wire harness (battery and ABS ECU circuit) • Connection of the ABS ECU coupler • Hydraulic unit assembly
ABS-32	Hydraulic unit solenoid relay is short-circuited.	<ul style="list-style-type: none"> • Hydraulic unit assembly
ABS-33	ABS motor is defective. Power is not supplied to the ABS motor.	<ul style="list-style-type: none"> • Battery voltage • ABS motor fuse • Wire harness (ABS circuit) • Connection of the ABS ECU coupler and starter relay coupler • Hydraulic unit assembly
ABS-34	Hydraulic unit ABS motor relay is short-circuited.	<ul style="list-style-type: none"> • Hydraulic unit assembly
ABS-41	Front wheel will not recover from the locking tendency even though the signal is continuously transmitted from the ABS ECU to release the hydraulic pressure.	<ul style="list-style-type: none"> • Brake dragging • Brake fluid • Hydraulic unit operation tests • Front wheel brake lines • Hydraulic unit assembly
ABS-42 ABS-47	Rear wheel will not recover from the locking tendency even though the signal is continuously transmitted from the ABS ECU to release the hydraulic pressure.	<ul style="list-style-type: none"> • Brake dragging • Brake fluid • Hydraulic unit operation tests • Rear wheel brake lines • Hydraulic unit assembly
ABS-43	Incorrect signal from the front wheel sensor is detected.	<ul style="list-style-type: none"> • Installation of the front wheel sensor • Front wheel sensor housing • Front wheel sensor rotor
ABS-44	Incorrect signal from the rear wheel sensor is detected.	<ul style="list-style-type: none"> • Installation of the rear wheel sensor • Rear wheel sensor housing • Rear wheel sensor rotor
ABS-51 ABS-52	Power voltage is too high.	<ul style="list-style-type: none"> • Battery voltage • Battery terminal • Refer to "CHARGING SYSTEM" on page 8-13.
ABS-53	Power voltage is too low.	<ul style="list-style-type: none"> • Battery voltage • Connection of the ABS ECU coupler • Wire harness • Refer to "CHARGING SYSTEM" on page 8-13.

ABS (ANTI-LOCK BRAKE SYSTEM)

Fault code No.	Symptom	Check point
ABS-54	Power voltage is too low.	<ul style="list-style-type: none">• Battery voltage• Connection of the ABS ECU coupler and starter relay coupler• Wire harness• Refer to “CHARGING SYSTEM” on page 8-13.
ABS-56	Hydraulic unit sensor power monitor circuit is abnormal.	<ul style="list-style-type: none">• Hydraulic unit assembly
ABS-63	Front wheel sensor power is abnormal.	<ul style="list-style-type: none">• Front wheel sensor lead• Wire harness• Hydraulic unit assembly
ABS-64	Rear wheel sensor power is abnormal.	<ul style="list-style-type: none">• Rear wheel sensor lead• Wire harness• Hydraulic unit assembly

* A fault code is indicated if the rear wheel rotates for longer than about 20 seconds (fault code No. ABS-11) or for longer than about 2 seconds (fault code No. ABS-25) with the front wheel stopped (e.g., when the vehicle is on the centerstand).

TIP

Fault codes No. ABS-15 (front wheel) and ABS-16 (rear wheel) are indicated if a defective connection is detected in the front or rear wheel sensor when the vehicle is not being ridden.

ABS (ANTI-LOCK BRAKE SYSTEM)

Fault code No.	ABS-11 ABS-25	Symptom	Front wheel sensor signal is not received properly.	
Order	Item/components and probable cause		Check or maintenance job	Reinstatement confirmation method
1	Installed condition of wheel sensor.		Check for looseness. Repair or replace the wheel sensor if necessary.	<ul style="list-style-type: none"> • Turn the main switch to “ON” and check that the ABS warning light comes on for 2 seconds, then goes off. • Perform a trial run at a constant speed of 30 km/h and check that the ABS warning light does not come on.
2	Installed condition of wheel bearings, axle, sensor housing, and sensor rotor.		Check the components for looseness, distortion, and bends. Refer to “CHECKING THE FRONT WHEEL” on page 4-14.	
3	Foreign material inside sensor housing.		Check the interior of the sensor housing and the surface of the sensor rotor for foreign material, such as metal particles. Clean the sensor housing and sensor rotor if necessary. Refer to “MAINTENANCE OF THE FRONT WHEEL SENSOR AND SENSOR ROTOR” on page 4-15.	
4	Defective sensor rotor.		Check the surface of the sensor rotor for damage. Replace the sensor rotor if there is visible damage. Refer to “MAINTENANCE OF THE FRONT WHEEL SENSOR AND SENSOR ROTOR” on page 4-15.	

TIP

With front wheel stopped, rear wheel was rotated for longer than about 20 seconds (fault code No. ABS-11) or for longer than about 2 seconds (fault code No. ABS-25).

ABS (ANTI-LOCK BRAKE SYSTEM)

Fault code No.	ABS-12	Symptom	Rear wheel sensor signal is not received properly.	
Order	Item/components and probable cause		Check or maintenance job	Reinstatement confirmation method
1	Installed condition of wheel sensor.		Check for looseness. Repair or replace the wheel sensor if necessary.	<ul style="list-style-type: none"> • Turn the main switch to “ON” and check that the ABS warning light comes on for 2 seconds, then goes off. • Perform a trial run at a constant speed of 30 km/h and check that the ABS warning light does not come on.
2	Installed condition of wheel bearings, axle, sensor housing, and sensor rotor.		Check the components for looseness, distortion, and bends. Refer to “CHECKING THE REAR WHEEL” on page 4-24.	
3	Foreign material inside sensor housing.		Check the interior of the sensor housing and the surface of the sensor rotor for foreign material, such as metal particles. Clean the sensor housing and sensor rotor if necessary. Refer to “MAINTENANCE OF THE REAR WHEEL SENSOR AND SENSOR ROTOR” on page 4-24.	
4	Defective sensor rotor.		Check the surface of the sensor rotor for damage. Replace the sensor rotor if there is visible damage. Refer to “MAINTENANCE OF THE REAR WHEEL SENSOR AND SENSOR ROTOR” on page 4-24.	

ABS (ANTI-LOCK BRAKE SYSTEM)

Fault code No.	ABS-13 ABS-26	Symptom	Incorrect signal from the front wheel sensor is detected.	
Order	Item/components and probable cause		Check or maintenance job	Reinstatement confirmation method
1	Installed condition of wheel sensor.		Check for looseness. Repair or replace the wheel sensor if necessary.	<ul style="list-style-type: none"> • Turn the main switch to “ON” and check that the ABS warning light comes on for 2 seconds, then goes off. • Perform a trial run at a constant speed of 30 km/h and check that the ABS warning light does not come on.
2	Installed condition of wheel bearings, axle, sensor housing, and sensor rotor.		Check the components for looseness, distortion, and bends. Refer to “CHECKING THE FRONT WHEEL” on page 4-14.	
3	Foreign material inside sensor housing.		Check the interior of the sensor housing and the surface of the sensor rotor for foreign material, such as metal particles. Clean the sensor housing and sensor rotor if necessary. Refer to “MAINTENANCE OF THE FRONT WHEEL SENSOR AND SENSOR ROTOR” on page 4-15.	
4	Defective sensor rotor.		Check the surface of the sensor rotor for damage. If there is visible damage, replace the sensor rotor. Refer to “MAINTENANCE OF THE FRONT WHEEL SENSOR AND SENSOR ROTOR” on page 4-15.	
5	Hydraulic unit assembly internal malfunction.		Replace the hydraulic unit assembly.	

TIP

Vehicle possibly ridden on uneven roads.

ABS (ANTI-LOCK BRAKE SYSTEM)

Fault code No.		ABS-14 ABS-27	Symptom	Incorrect signal from the rear wheel sensor is detected.	
Order	Item/components and probable cause		Check or maintenance job	Reinstatement confirmation method	
1	Installed condition of wheel sensor.		Check for looseness. Repair or replace the wheel sensor if necessary.	<ul style="list-style-type: none"> • Turn the main switch to "ON" and check that the ABS warning light comes on for 2 seconds, then goes off. • Perform a trial run at a constant speed of 30 km/h and check that the ABS warning light does not come on. 	
2	Installed condition of wheel bearings, axle, sensor housing, and sensor rotor.		Check the components for looseness, distortion, and bends. Refer to "CHECKING THE REAR WHEEL" on page 4-24.		
3	Foreign material inside sensor housing.		Check the interior of the sensor housing and the surface of the sensor rotor for foreign material, such as metal particles. Clean the sensor housing and sensor rotor if necessary. Refer to "MAINTENANCE OF THE REAR WHEEL SENSOR AND SENSOR ROTOR" on page 4-24.		
4	Defective sensor rotor.		Check the surface of the sensor rotor for damage. If there is visible damage, replace the sensor rotor. Refer to "MAINTENANCE OF THE REAR WHEEL SENSOR AND SENSOR ROTOR" on page 4-24.		
5	Hydraulic unit assembly internal malfunction.		Replace the hydraulic unit assembly.		

TIP _____

Vehicle possibly ridden on uneven roads.

Fault code No.		ABS-15	Symptom	No continuity in the front wheel sensor circuit.	
Order	Item/components and probable cause		Check or maintenance job	Reinstatement confirmation method	
1	Connections <ul style="list-style-type: none"> • Front wheel sensor coupler • ABS ECU coupler 		<ul style="list-style-type: none"> • Check the coupler for any pins that may be pulled out. • Check the locking condition of the coupler. • If there is a malfunction, repair it and connect the coupler securely. <p>TIP _____</p> Turn the main switch to "OFF" before disconnecting or connecting a coupler.	Turn the main switch to "ON" and check that the ABS warning light comes on for 2 seconds, then goes off.	

ABS (ANTI-LOCK BRAKE SYSTEM)

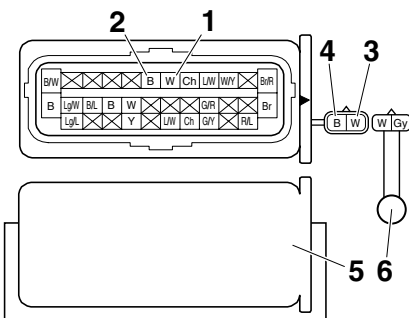
Fault code No.	ABS-15	Symptom	No continuity in the front wheel sensor circuit.	
Order	Item/components and probable cause		Check or maintenance job	Reinstatement confirmation method
2	Wire harness continuity.		<ul style="list-style-type: none"> Check for continuity between the white terminal "1" and the white terminal "3" and between the black terminal "2" and the black terminal "4". If there is no continuity, the wire harness is defective. Properly repair or replace the wire harness. Check that there is no continuity between the ground and the white terminal "1" or white terminal "3" and between the ground and the black terminal "2" or black terminal "4". If there is continuity, the wire harness is defective. Properly repair or replace the wire harness. Check that there is no continuity between the white terminal "1" and the black terminal "2" and between the white terminal "3" and the black terminal "4". If there is continuity, the wire harness is defective. Properly repair or replace the wire harness. <div style="text-align: center; margin-top: 10px;">  </div> <p style="margin-top: 10px;">5. ABS ECU 6. Front wheel sensor</p>	

ABS (ANTI-LOCK BRAKE SYSTEM)

Fault code No.	ABS-15	Symptom	No continuity in the front wheel sensor circuit.	
Order	Item/components and probable cause		Check or maintenance job	Reinstatement confirmation method
3	Defective wheel sensor.		<p>If the above items were performed and no malfunctions were found, connect the ABS ECU coupler and front wheel sensor coupler, and then delete the fault codes. If fault code No. ABS-15 could not be deleted, the front wheel sensor is defective. Replace the front wheel sensor.</p> <p>TIP _____</p> <p>Before deleting the fault codes, record all of the fault codes and perform the related checks and maintenance.</p> <p>_____</p>	

Fault code No.	ABS-16	Symptom	No continuity in the rear wheel sensor circuit.	
Order	Item/components and probable cause		Check or maintenance job	Reinstatement confirmation method
1	Connections <ul style="list-style-type: none"> • Rear wheel sensor coupler • ABS ECU coupler 		<ul style="list-style-type: none"> • Check the coupler for any pins that may be pulled out. • Check the locking condition of the coupler. • If there is a malfunction, repair it and connect the coupler securely. <p>TIP _____</p> <p>Turn the main switch to "OFF" before disconnecting or connecting a coupler.</p> <p>_____</p>	Turn the main switch to "ON" and check that the ABS warning light comes on for 2 seconds, then goes off.

ABS (ANTI-LOCK BRAKE SYSTEM)

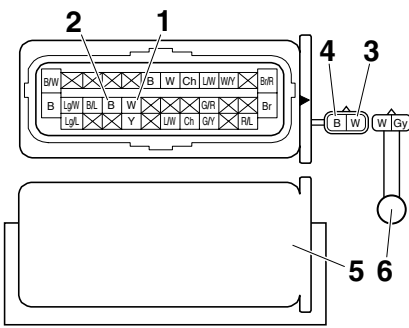
Fault code No.	ABS-16	Symptom	No continuity in the rear wheel sensor circuit.		
Order	Item/components and probable cause		Check or maintenance job	Reinstatement confirmation method	
2	Wire harness continuity.		<ul style="list-style-type: none"> Check for continuity between the white terminal "1" and the white terminal "3" and between the black terminal "2" and the black terminal "4". If there is no continuity, the wire harness is defective. Properly repair or replace the wire harness. Check that there is no continuity between the ground and the white terminal "1" or white terminal "3" and between the ground and the black terminal "2" or black terminal "4". If there is continuity, the wire harness is defective. Properly repair or replace the wire harness. Check that there is no continuity between the white terminal "1" and the black terminal "2" and between the white terminal "3" and the black terminal "4". If there is continuity, the wire harness is defective. Properly repair or replace the wire harness. <div style="text-align: center;">  </div> <p style="margin-left: 20px;">5. ABS ECU 6. Rear wheel sensor</p>		

ABS (ANTI-LOCK BRAKE SYSTEM)

Fault code No.	ABS-16	Symptom	No continuity in the rear wheel sensor circuit.	
Order	Item/components and probable cause		Check or maintenance job	Reinstatement confirmation method
3	Defective wheel sensor.		<p>If the above items were performed and no malfunctions were found, connect the ABS ECU coupler and rear wheel sensor coupler, and then delete the fault codes. If fault code No. ABS-16 could not be deleted, the rear wheel sensor is defective. Replace the rear wheel sensor.</p> <p>TIP</p> <p>Before deleting the fault codes, record all of the fault codes and perform the related checks and maintenance.</p>	

Fault code No.	ABS-17 ABS-45	Symptom	Missing pulses detected in the front wheel sensor signal.	
Order	Item/components and probable cause		Check or maintenance job	Reinstatement confirmation method
1	Installed condition of wheel bearings, axle, sensor housing, and sensor rotor.		Check the components for looseness, distortion, and bends. Refer to "CHECKING THE FRONT WHEEL" on page 4-14.	<ul style="list-style-type: none"> • Turn the main switch to "ON" and check that the ABS warning light comes on for 2 seconds, then goes off. • Perform a trial run at a constant speed of 30 km/h and check that the ABS warning light does not come on.
2	Foreign material inside sensor housing.		Check the interior of the sensor housing and the surface of the sensor rotor for foreign material, such as metal particles. Clean the sensor housing and sensor rotor if necessary. Refer to "MAINTENANCE OF THE FRONT WHEEL SENSOR AND SENSOR ROTOR" on page 4-15.	
3	Defective sensor rotor.		<ul style="list-style-type: none"> • Check the surface of the sensor rotor for damage. • If there is visible damage, replace the sensor rotor. 	

ABS (ANTI-LOCK BRAKE SYSTEM)

Fault code No.	ABS-18 ABS-46	Symptom	Missing pulses detected in the rear wheel sensor signal.	
Order	Item/components and probable cause	Check or maintenance job	Reinstatement confirmation method	
1	Installed condition of wheel bearings, axle, sensor housing, and sensor rotor.	Check the components for looseness, distortion, and bends. Refer to "CHECKING THE REAR WHEEL" on page 4-24.	<ul style="list-style-type: none"> • Turn the main switch to "ON" and check that the ABS warning light comes on for 2 seconds, then goes off. • Perform a trial run at a constant speed of 30 km/h and check that the ABS warning light does not come on. 	
2	Foreign material inside sensor housing.	Check the interior of the sensor housing and the surface of the sensor rotor for foreign material, such as metal particles. Clean the sensor housing and sensor rotor if necessary. Refer to "MAINTENANCE OF THE REAR WHEEL SENSOR AND SENSOR ROTOR" on page 4-24.		
3	Defective sensor rotor.	<ul style="list-style-type: none"> • Check the surface of the sensor rotor for damage. • If there is visible damage, replace the sensor rotor. 		

Fault code No.	ABS-21	Symptom	Hydraulic unit solenoid circuit is open or short-circuited.	
Order	Item/components and probable cause	Check or maintenance job	Reinstatement confirmation method	
1	Open or short circuit in solenoid circuit.	Replace the hydraulic unit assembly.	<ul style="list-style-type: none"> • Turn the main switch to "ON" and check that the ABS warning light comes on for 2 seconds, then goes off. • Perform hydraulic unit operation test 1 and check that the operation of the hydraulic unit is normal. 	

ABS (ANTI-LOCK BRAKE SYSTEM)

Fault code No.	ABS-22	Symptom	Start switch signal is not received properly (start switch circuit or start switch monitor circuit).	
Order	Item/components and probable cause		Check or maintenance job	Reinstatement confirmation method
1	Engine startability.		Check the electric starting system. Refer to "ELECTRIC STARTING SYSTEM" on page 8-7.	<ul style="list-style-type: none"> • Push the start switch and check that the engine starts.
2	Connections <ul style="list-style-type: none"> • Starter relay coupler • ABS ECU coupler • Right handlebar switch coupler 		<ul style="list-style-type: none"> • Check the coupler for any pins that may be pulled out. • Check the locking condition of the coupler. • If there is a malfunction, repair it and connect the coupler securely. <p>TIP _____</p> Turn the main switch to "OFF" before disconnecting or connecting a coupler. _____	<ul style="list-style-type: none"> • Turn the main switch to "ON" and check that the ABS warning light comes on for 2 seconds, then goes off. • Check that the ABS warning light comes on while the start switch is being pushed.
3	Open or short circuit in wire harness.		<ul style="list-style-type: none"> • Repair or replace if there is an open or short circuit. • Between ABS ECU coupler and starter relay coupler. (blue/white–blue/white) • Between ABS ECU coupler and right handlebar switch (start switch) coupler. (blue/white–blue/white) 	

ABS (ANTI-LOCK BRAKE SYSTEM)

Fault code No.	ABS-24	Symptom	Brake light signal is not received properly while vehicle is traveling (brake light circuit, or front or rear brake light switch circuit).	
Order	Item/components and probable cause		Check or maintenance job	Reinstatement confirmation method
1	Brake light operation. • Defective tail/brake light		Check the tail/brake light. Replace the tail/brake light if necessary.	<ul style="list-style-type: none"> • Check that the brake light comes on when the front or rear brake is applied. • Turn the main switch to “ON” and check that the ABS warning light comes on for 2 seconds, then goes off. • Check that the ABS warning light does not flash when the front, rear, or both brakes are applied for 2 seconds or more.
2	Connections • ABS ECU coupler • Front brake light switch connectors • Rear brake light switch coupler		<ul style="list-style-type: none"> • Check the coupler for any pins that may be pulled out. • Check the locking condition of the coupler. • If there is a malfunction, repair it and connect the coupler securely. <p>TIP _____ Turn the main switch to “OFF” before disconnecting or connecting a coupler.</p>	
3	Open or short circuit in wire harness.		<ul style="list-style-type: none"> • Repair or replace if there is an open or short circuit. • Between rear brake light switch coupler and ABS ECU coupler. (yellow–yellow) • Between front brake light switch connectors and ABS ECU coupler. (yellow–yellow) 	
4	Water inside switch.		Use compressed air to blow out the water.	

ABS (ANTI-LOCK BRAKE SYSTEM)

Fault code No.	ABS-31	Symptom	Solenoid relay is defective. Power is not supplied to the solenoid relay.	
Order	Item/components and probable cause		Check or maintenance job	Reinstatement confirmation method
1	Battery voltage		Recharge or replace the battery. Refer to "CHECKING AND CHARGING THE BATTERY" on page 3-34.	Turn the main switch to "ON" and check that the ABS warning light comes on for 2 seconds, then goes off.
2	Blown ABS solenoid fuse.		Check the ABS solenoid fuse. If the ABS solenoid fuse is blown, replace the fuse and check the wire harness. Refer to "CHECKING THE FUSES" on page 3-34.	
3	Connections • ABS ECU coupler		<ul style="list-style-type: none"> • Check the coupler for any pins that may be pulled out. • Check the locking condition of the coupler. • If there is a malfunction, repair it and connect the coupler securely. <p>TIP _____ Turn the main switch to "OFF" before disconnecting or connecting a coupler. _____</p>	
4	Open or short circuit in wire harness.		<ul style="list-style-type: none"> • Repair or replace if there is an open or short circuit. • Between ABS ECU coupler and ABS solenoid fuse. (brown/red–brown/red) 	
5	Hydraulic unit assembly internal malfunction.		Replace the hydraulic unit assembly.	

ABS (ANTI-LOCK BRAKE SYSTEM)

Fault code No.	ABS-32	Symptom	Hydraulic unit solenoid relay is short-circuited.	
Order	Item/components and probable cause		Check or maintenance job	Reinstatement confirmation method
1	Short circuit in solenoid relay.		Replace the hydraulic unit assembly.	<ul style="list-style-type: none">• Turn the main switch to "ON" and check that the ABS warning light comes on for 2 seconds, then goes off.• Perform hydraulic unit operation test 1 and check that the operation of the hydraulic unit is normal.
2	Hydraulic unit assembly internal malfunction.		Replace the hydraulic unit assembly.	

ABS (ANTI-LOCK BRAKE SYSTEM)

Fault code No.	ABS-33	Symptom	ABS motor is defective. Power is not supplied to the ABS motor.	
Order	Item/components and probable cause		Check or maintenance job	Reinstatement confirmation method
1	Battery voltage		Recharge or replace the battery. Refer to "CHECKING AND CHARGING THE BATTERY" on page 3-34.	<ul style="list-style-type: none"> • Turn the main switch to "ON" and check that the ABS warning light comes on for 2 seconds, then goes off. • Perform hydraulic unit operation test 1 and check that the operation of the hydraulic unit is normal.
2	Blown ABS motor fuse.		Check the ABS motor fuse. If the ABS motor fuse is blown, replace the fuse and check the wire harness. Refer to "CHECKING THE FUSES" on page 3-34.	
3	Connections <ul style="list-style-type: none"> • ABS ECU coupler • Starter relay coupler 		<ul style="list-style-type: none"> • Check the coupler for any pins that may be pulled out. • Check the locking condition of the coupler. • If there is a malfunction, repair it and connect the coupler securely. <p>TIP _____</p> Turn the main switch to "OFF" before disconnecting or connecting a coupler.	
4	Open or short circuit in wire harness.		<ul style="list-style-type: none"> • Repair or replace if there is an open or short circuit. • Between ABS ECU coupler and starter relay coupler. (brown–brown) • Between ABS ECU coupler and ground. (black–black) 	
5	Hydraulic unit assembly internal malfunction.		Replace the hydraulic unit assembly.	

ABS (ANTI-LOCK BRAKE SYSTEM)

Fault code No.	ABS-34	Symptom	Hydraulic unit ABS motor relay is short-circuited.	
Order	Item/components and probable cause		Check or maintenance job	Reinstatement confirmation method
1	Short circuit in ABS motor relay.		Replace the hydraulic unit assembly.	<ul style="list-style-type: none"> • Turn the main switch to “ON” and check that the ABS warning light comes on for 2 seconds, then goes off. • Perform hydraulic unit operation test 1 and check that the operation of the hydraulic unit is normal.

Fault code No.	ABS-41	Symptom	Front wheel will not recover from the locking tendency even though the signal is continuously transmitted from the ABS ECU to release the hydraulic pressure (when the battery voltage is normal)	
Order	Item/components and probable cause		Check or maintenance job	Reinstatement confirmation method
1	Rotation of wheel		<ul style="list-style-type: none"> • Check that there is no brake disc drag on the front wheel and make sure that it rotates smoothly. • Check the front wheel axle for loose bearings and bends, and the brake discs for distortion. Refer to “CHECKING THE FRONT BRAKE DISCS” on page 4-34. 	Perform hydraulic unit operation test 1 and check that the operation of the hydraulic unit is normal.
2	Brake master cylinder and brake caliper		<ul style="list-style-type: none"> • Check that the brake fluid pressure is correctly transmitted to the brake calipers when the brake lever is operated and that the pressure decreases when the lever is released. 	
3	Brake fluid		<ul style="list-style-type: none"> • Visually check the brake fluid in the brake master cylinder reservoir for water, foreign materials, solidification, and contamination. • Check for air in the brake lines. 	

ABS (ANTI-LOCK BRAKE SYSTEM)

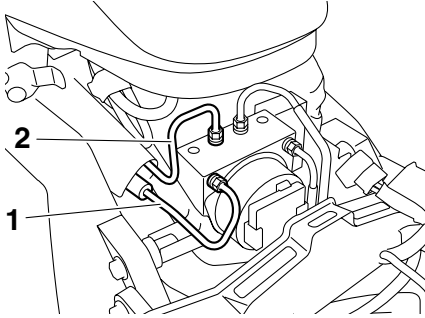
Fault code No.	ABS-41	Symptom	Front wheel will not recover from the locking tendency even though the signal is continuously transmitted from the ABS ECU to release the hydraulic pressure (when the battery voltage is normal)	
Order	Item/components and probable cause		Check or maintenance job	Reinstatement confirmation method
4	Brake lines		<ul style="list-style-type: none"> • Check the brake lines for kinks and deterioration. <p style="font-size: small; margin: 0;">EWA2S31023</p> <div style="border: 1px solid black; padding: 2px; display: inline-block; margin-bottom: 5px;"> WARNING </div> <p style="margin: 0;">Only use genuine Yamaha parts. Using other brake pipes, hoses and union bolts may close the brake lines.</p> <ul style="list-style-type: none"> • Check that the connections of the brake lines from the brake master cylinder to the hydraulic unit and from the hydraulic unit to the left front brake caliper are correct. <div style="text-align: center; margin: 10px 0;">  </div> <p style="margin: 0;">See WARNING and TIP.</p>	

ABS (ANTI-LOCK BRAKE SYSTEM)

Fault code No.	ABS-41	Symptom	Front wheel will not recover from the locking tendency even though the signal is continuously transmitted from the ABS ECU to release the hydraulic pressure (when the battery voltage is normal)	
Order	Item/components and probable cause		Check or maintenance job	Reinstatement confirmation method
5	Hydraulic unit assembly		If the malfunction is not corrected after checking items (1) to (4), replace the hydraulic unit assembly. Be sure to connect the brake hoses and coupler correctly and securely. Check the hydraulic unit operation. Refer to "HYDRAULIC UNIT OPERATION TESTS" on page 4-59.	

EWA2S31024

WARNING

The front brakes will not function properly if the connections are reversed.

- **Brake hose (front brake master cylinder to hydraulic unit) "1" inlet: from the front brake master cylinder**
- **Brake hose (hydraulic unit to left front brake caliper) "2" outlet: to the left front brake caliper**

TIP

- If the brake hose inlet and outlet connections are incorrect on the hydraulic unit, the brake lever will be pulled to its full-stroke position without responding, and then it will be pushed back slowly without pulsating when the final check on page "[D-3] FINAL CHECK" on page 8-115 is performed.
- If the front and rear brake hose connections are reversed on the hydraulic unit, the pulsating action in the brake lever and brake pedal will be performed in the reverse order when the final check on page "[D-3] FINAL CHECK" on page 8-115 is performed.

ABS (ANTI-LOCK BRAKE SYSTEM)

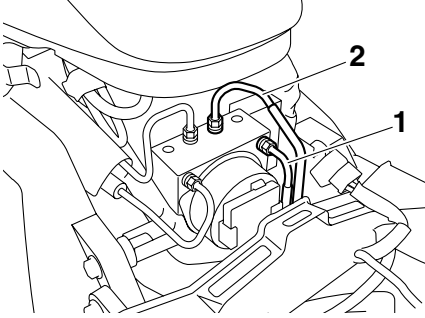
Fault code No.	ABS-42 ABS-47	Symptom	Rear wheel will not recover from the locking tendency even though the signal is continuously transmitted from the ABS ECU to release the hydraulic pressure.	
Order	Item/components and probable cause	Check or maintenance job	Reinstatement confirmation method	
1	Rotation of wheel	<ul style="list-style-type: none"> • Check that there is no brake disc drag on the rear wheel and make sure that it rotates smoothly. • Check for brake disc distortion. Refer to "CHECKING THE REAR BRAKE DISC" on page 4-47. 	Perform hydraulic unit operation test 1 and check that the operation of the hydraulic unit is normal.	
2	Brake master cylinder and brake caliper	<ul style="list-style-type: none"> • Check that the brake fluid pressure is correctly transmitted to the brake caliper when the brake pedal is operated and that the pressure decreases when the pedal is released. 		
3	Brake fluid	<ul style="list-style-type: none"> • Visually check the brake fluid in the brake fluid reservoir for water, foreign materials, solidification, and contamination. • Check for air in the brake lines. 		
4	Brake lines	<ul style="list-style-type: none"> • Check the brake lines for kinks and deterioration (particularly between the hydraulic unit and the rear brake caliper). <p style="font-size: small;">EWA2S31023</p> <div style="border: 1px solid black; padding: 2px; display: inline-block;"> WARNING </div> <p>Only use genuine Yamaha parts. Using other brake pipes, hoses and union bolts may close the brake lines.</p> <ul style="list-style-type: none"> • Check that the connections of the brake lines from the brake master cylinder to the hydraulic unit are correct.  <p>See WARNING and TIP.</p>		

ABS (ANTI-LOCK BRAKE SYSTEM)

Fault code No.	ABS-42 ABS-47	Symptom	Rear wheel will not recover from the locking tendency even though the signal is continuously transmitted from the ABS ECU to release the hydraulic pressure.	
Order	Item/components and probable cause		Check or maintenance job	Reinstatement confirmation method
5	Hydraulic unit assembly		If the malfunction is not corrected after checking items (1) to (4), replace the hydraulic unit assembly. Be sure to connect the brake hose, and coupler correctly and securely. Check the hydraulic unit operation. Refer to "HYDRAULIC UNIT OPERATION TESTS" on page 4-59.	

EWA2S31025

WARNING

The rear brake will not function properly if the connections are reversed.

- **Brake hose (rear brake master cylinder to hydraulic unit) "1" inlet: from the rear brake master cylinder**
- **Brake hose (hydraulic unit to rear brake caliper) "2" outlet: to the rear brake caliper**

TIP

- If the brake hose inlet and outlet connections are reversed on the hydraulic unit, the brake pedal will be pressed down to its full-stroke position without responding, and then it will be pushed back slowly without pulsating when the final check on page "[D-3] FINAL CHECK" on page 8-115 is performed.
- If the front and rear brake hose connections are reversed on the hydraulic unit, the pulsating action in the brake lever and brake pedal will be performed in the reverse order when the final check on page "[D-3] FINAL CHECK" on page 8-115 is performed.

ABS (ANTI-LOCK BRAKE SYSTEM)

Fault code No.	ABS-43	Symptom	Incorrect signal from the front wheel sensor is detected.	
Order	Item/components and probable cause		Check or maintenance job	Reinstatement confirmation method
1	Installed condition of wheel sensor.		Check for looseness. Repair or replace the wheel sensor if necessary.	<ul style="list-style-type: none"> • Turn the main switch to “ON” and check that the ABS warning light comes on for 2 seconds, then goes off. • Perform a trial run at a constant speed of 30 km/h and check that the ABS warning light does not come on.
2	Installed condition of wheel bearings, axle, sensor housing, and sensor rotor.		Check the components for looseness, distortion, and bends. Refer to “CHECKING THE FRONT WHEEL” on page 4-14.	
3	Foreign material inside sensor housing.		Check the interior of the sensor housing and the surface of the sensor rotor for foreign material, such as metal particles. Clean the sensor housing and sensor rotor if necessary. Refer to “MAINTENANCE OF THE FRONT WHEEL SENSOR AND SENSOR ROTOR” on page 4-15.	
4	Defective sensor rotor.		<ul style="list-style-type: none"> • Check the surface of the sensor rotor for damage. • If there is visible damage, replace the sensor rotor. 	

ABS (ANTI-LOCK BRAKE SYSTEM)

Fault code No.		ABS-44	Symptom	Incorrect signal from the rear wheel sensor is detected.	
Order	Item/components and probable cause		Check or maintenance job	Reinstatement confirmation method	
1	Installed condition of wheel sensor.		Check for looseness. Repair or replace the wheel sensor if necessary.	<ul style="list-style-type: none"> • Turn the main switch to "ON" and check that the ABS warning light comes on for 2 seconds, then goes off. • Perform a trial run at a constant speed of 30 km/h and check that the ABS warning light does not come on. 	
2	Installed condition of wheel bearings, axle, sensor housing, and sensor rotor.		Check the components for looseness, distortion, and bends. Refer to "CHECKING THE REAR WHEEL" on page 4-24.		
3	Foreign material inside sensor housing.		Check the interior of the sensor housing and the surface of the sensor rotor for foreign material, such as metal particles. Clean the sensor housing and sensor rotor if necessary. Refer to "MAINTENANCE OF THE REAR WHEEL SENSOR AND SENSOR ROTOR" on page 4-24.		
4	Defective sensor rotor.		<ul style="list-style-type: none"> • Check the surface of the sensor rotor for damage. • If there is visible damage, replace the sensor rotor. 		

Fault code No.		ABS-51 ABS-52	Symptom	Power voltage is too high.	
Order	Item/components and probable cause		Check or maintenance job	Reinstatement confirmation method	
1	Battery voltage		Replace the battery. Refer to "CHECKING AND CHARGING THE BATTERY" on page 3-34.	<ul style="list-style-type: none"> • Turn the main switch to "ON" and check that the ABS warning light comes on for 2 seconds, then goes off. • Perform a trial run and check that the ABS warning light does not come on. 	
2	Disconnected battery terminal (fault code No. ABS-52).		Check the connection. Replace or reconnect the terminal if necessary.		
3	Charging system		Check the charging system. Refer to "CHARGING SYSTEM" on page 8-13.		

ABS (ANTI-LOCK BRAKE SYSTEM)

Fault code No.	ABS-53	Symptom	Power voltage is too low.	
Order	Item/components and probable cause		Check or maintenance job	Reinstatement confirmation method
1	Battery voltage		Recharge or replace the battery. Refer to "CHECKING AND CHARGING THE BATTERY" on page 3-34.	<ul style="list-style-type: none"> • Turn the main switch to "ON" and check that the ABS warning light comes on for 2 seconds, then goes off. • Perform a trial run and check that the ABS warning light does not come on.
2	Connections <ul style="list-style-type: none"> • ABS ECU coupler 		<ul style="list-style-type: none"> • Check the coupler for any pins that may be pulled out. • Check the locking condition of the coupler. • If there is a malfunction, repair it and connect the coupler securely. <p>TIP _____</p> Turn the main switch to "OFF" before disconnecting or connecting a coupler. <hr style="width: 100%;"/>	
3	Open or short circuit in wire harness.		<ul style="list-style-type: none"> • Repair or replace if there is an open or short circuit. • Between ABS ECU coupler and ABS ECU fuse. (red/blue-red/blue) 	
4	Charging system		Check the charging system. Refer to "CHARGING SYSTEM" on page 8-13.	

ABS (ANTI-LOCK BRAKE SYSTEM)

Fault code No.	ABS-54	Symptom	Power voltage is too low.	
Order	Item/components and probable cause		Check or maintenance job	Reinstatement confirmation method
1	Battery voltage		Recharge or replace the battery. Refer to "CHECKING AND CHARGING THE BATTERY" on page 3-34.	<ul style="list-style-type: none"> • Turn the main switch to "ON" and check that the ABS warning light comes on for 2 seconds, then goes off. • Perform a trial run and check that the ABS warning light does not come on.
2	Connections <ul style="list-style-type: none"> • ABS ECU coupler • Starter relay coupler 		<ul style="list-style-type: none"> • Check the coupler for any pins that may be pulled out. • Check the locking condition of the coupler. • If there is a malfunction, repair it and connect the coupler securely. <p>TIP _____</p> Turn the main switch to "OFF" before disconnecting or connecting a coupler.	
3	Open or short circuit in wire harness.		<ul style="list-style-type: none"> • Repair or replace if there is an open or short circuit. • Between ABS ECU coupler and ABS ECU fuse. (red/blue-red/blue) • Between ABS ECU coupler and ABS solenoid fuse. (brown/red-brown/red) • Between ABS ECU coupler and starter relay coupler. (brown-brown) 	
4	Charging system		Check the charging system. Refer to "CHARGING SYSTEM" on page 8-13.	

ABS (ANTI-LOCK BRAKE SYSTEM)

Fault code No.	ABS-56	Symptom	Hydraulic unit sensor power monitor circuit is abnormal.	
Order	Item/components and probable cause		Check or maintenance job	Reinstatement confirmation method
1	Defective internal monitor circuit (sensor power).		Replace the hydraulic unit assembly.	<ul style="list-style-type: none">• Turn the main switch to "ON" and check that the ABS warning light comes on for 2 seconds, then goes off.• Perform hydraulic unit operation test 1 and check that the operation of the hydraulic unit is normal.

ABS (ANTI-LOCK BRAKE SYSTEM)

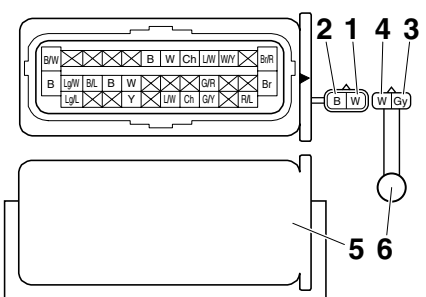
Fault code No.	ABS-63	Symptom	Front wheel sensor power is abnormal.	
Order	Item/components and probable cause		Check or maintenance job	Reinstatement confirmation method
1	Short circuit in wire harness.		<ul style="list-style-type: none"> • Check that there is no short circuit between the white terminal “1” and the black terminal “2”. • Check that there is no short circuit between the frame ground and the black terminal “2”. • If there is a short circuit, the wire harness is defective. Properly repair or replace the wire harness. <p>TIP</p> <p>Disconnect the ABS ECU coupler before checking the wire harness.</p>	Turn the main switch to “ON” and check that the ABS warning light comes on for 2 seconds, then goes off.
2	Short circuit in front wheel sensor lead.		<ul style="list-style-type: none"> • Check that there is no short circuit between the gray terminal “3” and the white terminal “4”. • Check that there is no short circuit between the frame ground and the gray terminal “3”. • If there is a short circuit, the front wheel sensor is defective. Properly repair or replace the front wheel sensor. <div style="text-align: center;">  </div> <p>5. ABS ECU 6. Front wheel sensor</p>	
3	Hydraulic unit internal malfunction.		Replace the hydraulic unit assembly.	

ABS (ANTI-LOCK BRAKE SYSTEM)

Fault code No.	ABS-64	Symptom	Rear wheel sensor power is abnormal.	
Order	Item/components and probable cause		Check or maintenance job	Reinstatement confirmation method
1	Short circuit in wire harness.		<ul style="list-style-type: none"> • Check that there is no short circuit between the white terminal “1” and the black terminal “2”. • Check that there is no short circuit between the frame ground and the black terminal “2”. • If there is a short circuit, the wire harness is defective. Properly repair or replace the wire harness. <p>TIP</p> <p>Disconnect the ABS ECU coupler before checking the wire harness.</p>	Turn the main switch to “ON” and check that the ABS warning light comes on for 2 seconds, then goes off.
2	Short circuit in rear wheel sensor lead.		<ul style="list-style-type: none"> • Check that there is no short circuit between the gray terminal “3” and the white terminal “4”. • Check that there is no short circuit between the frame ground and the gray terminal “3”. • If there is a short circuit, the rear wheel sensor is defective. Properly repair or replace the rear wheel sensor. <div style="text-align: center;"> <p>5. ABS ECU 6. Rear wheel sensor</p> </div>	
3	Hydraulic unit internal malfunction.		Replace the hydraulic unit assembly.	

ABS (ANTI-LOCK BRAKE SYSTEM)

EAS2S31075

[D-1] DELETING THE FAULT CODES

1. Connect the test coupler adapter "1" to the ABS test coupler "2". Refer to "[B-5] MALFUNCTION ARE CURRENTLY DETECTED" on page 8-83.

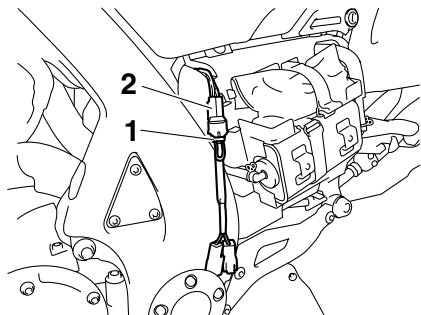

2. Turn the main switch to "ON".
Fault codes will be displayed in the multi-function display.
3. Set the engine stop switch "1" to "⊗".

ECA2S31055

NOTICE

If the start switch is pushed without setting the engine stop switch to "⊗", the starter motor gears or other parts may be damaged.

4. Without operating the brake lever, push the start switch "2" at least 10 times in 4 seconds to delete the fault codes.

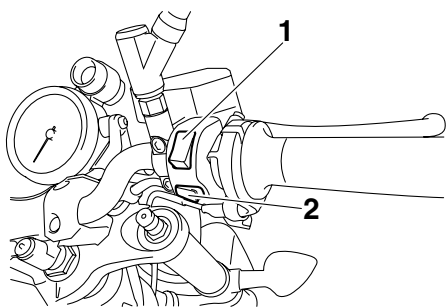

5. The multi-function display switches to the odometer display and the ABS warning light flashes in 0.5 second-intervals while the fault codes are being deleted.
6. Turn the main switch to "OFF".
7. Turn the main switch to "ON" again.

TIP

If fault codes are still displayed in the multi-function display, the malfunctions have not been repaired. Diagnose the malfunctions using the fault codes.

8. Turn the main switch to "OFF".
9. Disconnect the test coupler adapter from the ABS test coupler, and then install the protective cap onto the ABS test coupler. Deleting the fault codes is now finished.

TIP

Do not forget to install the protective cap onto the ABS test coupler.

ECA2S31056

NOTICE

Since the fault codes remain in the memory of the ABS ECU until they are deleted, always delete the fault codes after the service has been completed.

EAS2S31076

[D-2] DELETE FUNCTION TEST

1. Place the vehicle on a suitable stand.
2. Turn the main switch to "OFF".
3. Connect the test coupler adapter to the ABS test coupler.
4. Turn the main switch to "ON".
5. Check:
 - ABS ECU voltage
Lower than 12.8 V → Charge or replace the battery.

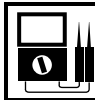

**Battery voltage
Higher than 12.8 V**

- a. Connect the pocket tester (DC 20 V) to the ABS ECU coupler.



**Pocket tester
90890-03112
Analog pocket tester
YU-03112-C**

- Positive tester probe → red/blue "1"
- Negative tester probe → black/white "2"

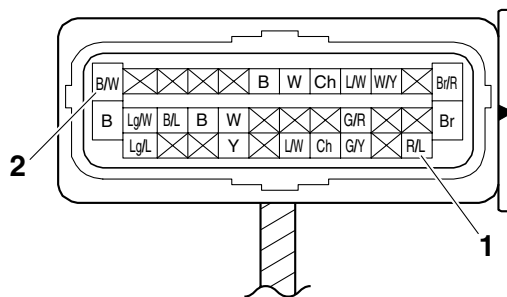

ABS (ANTI-LOCK BRAKE SYSTEM)

b. Measure the ABS ECU voltage.



6. Check:

- ABS-ECU-to-start-switch-lead continuity
No continuity → Replace or repair the wire harness.

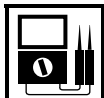

Continuity is all right.



a. Connect the pocket tester ($\Omega \times 1$) to the ABS ECU coupler and right handlebar switch coupler.



**Pocket tester
90890-03112
Analog pocket tester
YU-03112-C**

- Positive tester probe → blue/white “1” (ABS ECU)
- Negative tester probe → blue/white “2” (right handlebar switch)

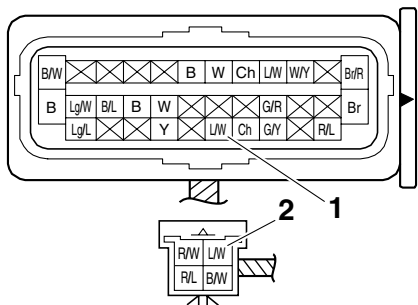

b. Check for continuity between the ABS ECU and the start switch lead.



7. Check:

- ABS ECU voltage
Out of specification → Replace the right handlebar switch.



**Start switch “ON”: less than 1 V
Start switch “OFF”: more than 12 V**



a. Connect the pocket tester (DC 12 V) to the ABS ECU coupler.



**Pocket tester
90890-03112
Analog pocket tester
YU-03112-C**

- Positive tester probe → blue/white “1”
- Negative tester probe → black/white “2”

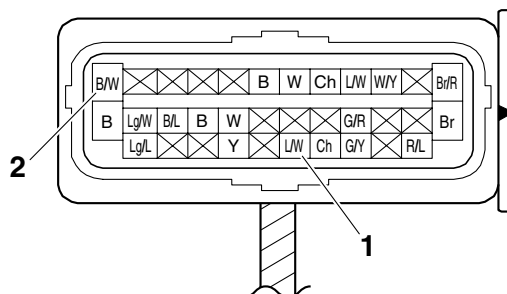

b. Push the start switch.
c. Measure the ABS ECU voltage.



8. If the above-mentioned checks are within specification, replace the hydraulic unit assembly.

EAS2S31091

[D-3] FINAL CHECK

Checking procedures

1. Check the brake fluid level in the brake master cylinder reservoir and brake fluid reservoir.
Refer to “CHECKING THE BRAKE FLUID LEVEL” on page 3-22.
2. Check the wheel sensor housings and wheel sensors for proper installation.
Refer to “INSTALLING THE FRONT WHEEL (FRONT BRAKE DISCS)” on page 4-18 and “INSTALLING THE REAR WHEEL (REAR BRAKE DISC)” on page 4-26.
3. Perform hydraulic unit operation test 1 or 2.
Refer to “HYDRAULIC UNIT OPERATION TESTS” on page 4-59.
4. Delete the fault codes.
Refer to “[D-1] DELETING THE FAULT CODES” on page 8-114.
5. Perform a trial run.
Refer to “TRIAL RUN” on page 4-62.

EAS27972

ELECTRICAL COMPONENTS

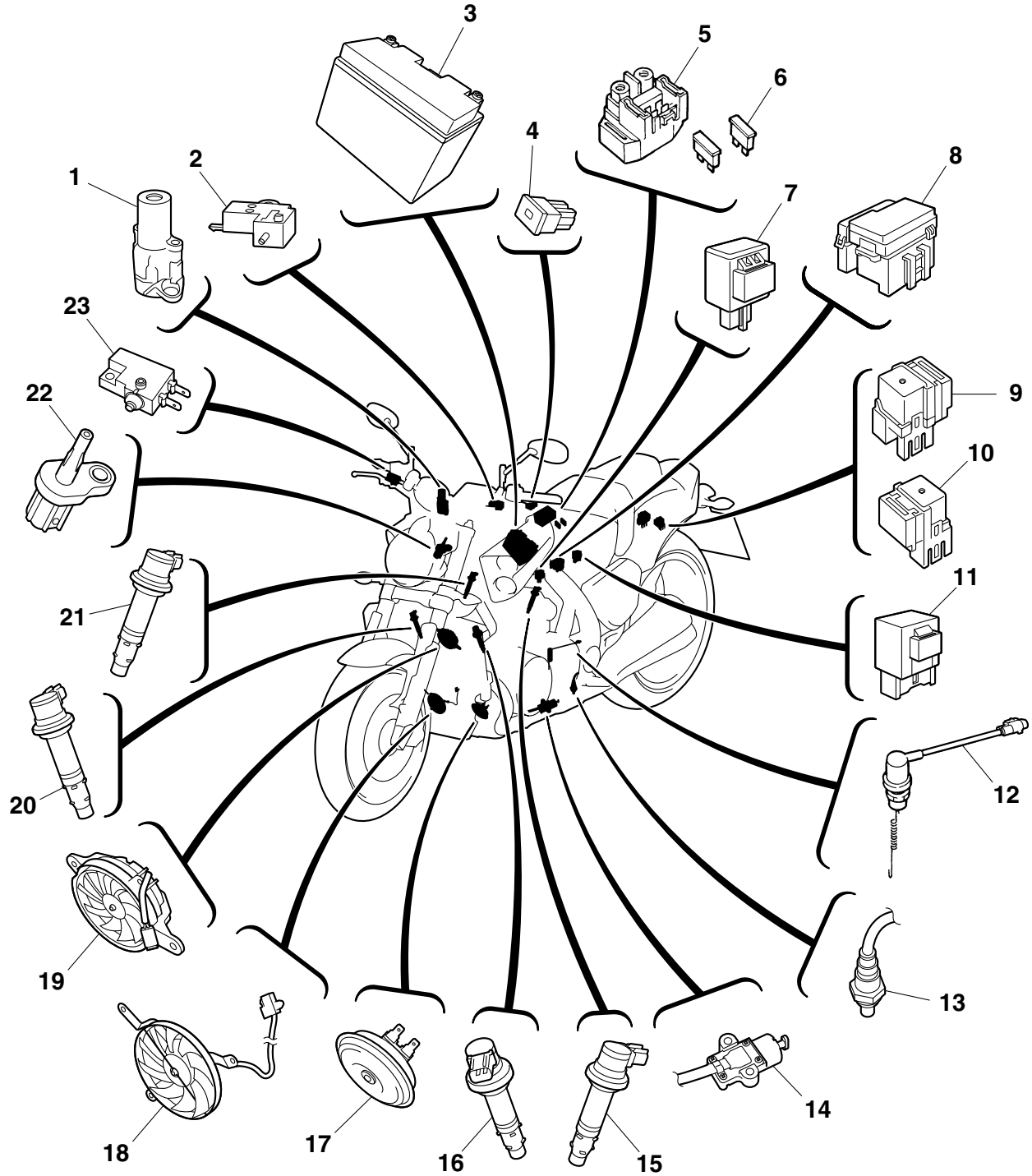

ELECTRICAL COMPONENTS

1. Main switch
2. Clutch switch
3. Battery
4. Main fuse
5. Starter relay
6. ABS motor fuse
7. Turn signal/hazard relay
8. Fuse box 1
9. Headlight relay
10. Radiator fan motor relay
11. Relay unit
12. Rear brake light switch
13. O₂ sensor
14. Sidestand switch
15. Cylinder-#1 ignition coil
16. Cylinder-#2 ignition coil
17. Horn
18. Main radiator fan
19. Sub radiator fan
20. Cylinder-#4 ignition coil
21. Cylinder-#3 ignition coil
22. Intake air temperature sensor
23. Front brake light switch

ELECTRICAL COMPONENTS

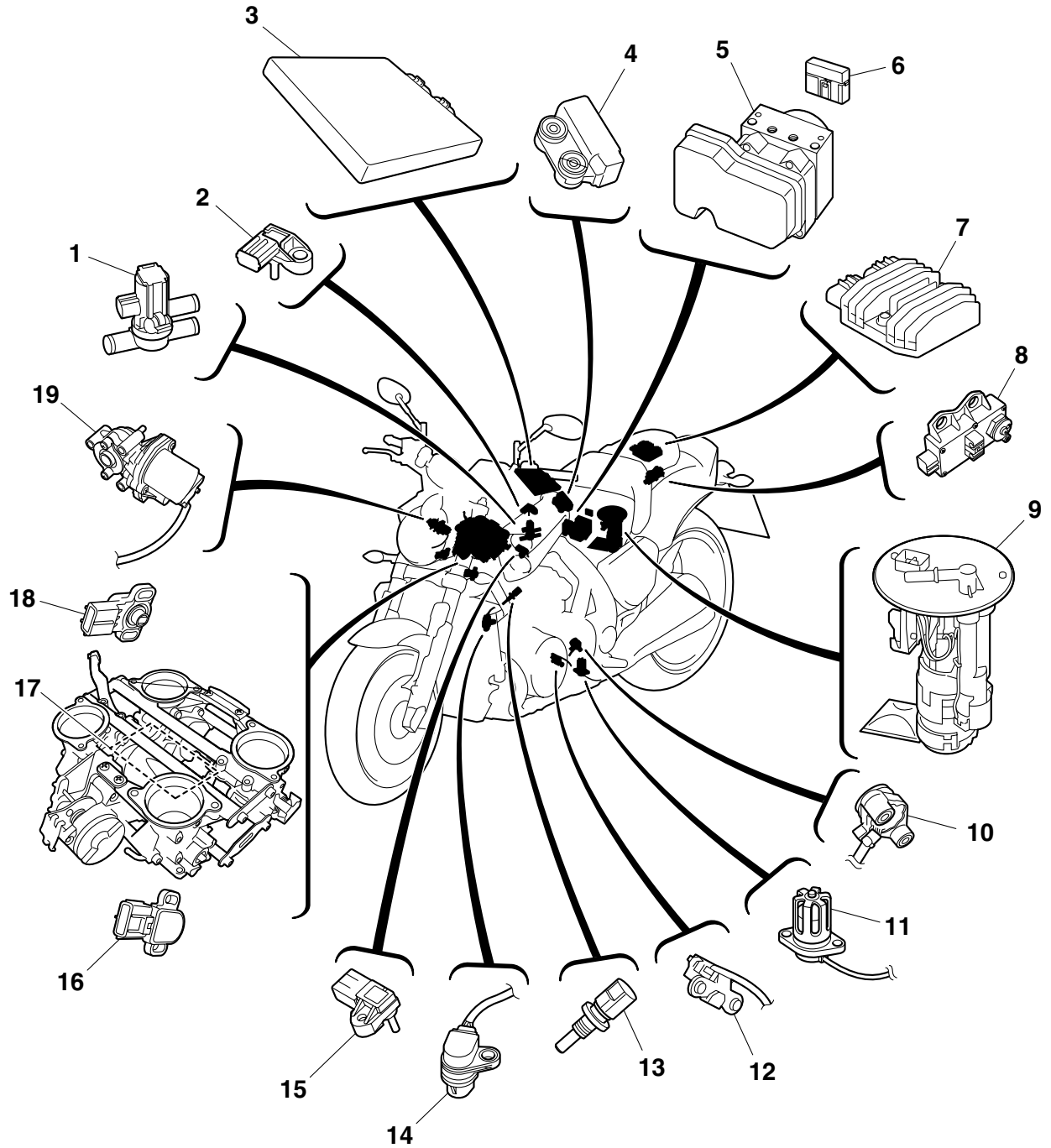

ELECTRICAL COMPONENTS

1. Air induction system solenoid
2. Atmospheric pressure sensor
3. ECU (engine control unit)
4. Lean angle sensor
5. Hydraulic unit assembly
6. Fuse box 2
7. Rectifier/regulator
8. EXUP servo motor
9. Fuel pump assembly
10. Gear position switch
11. Oil level switch
12. Crankshaft position sensor
13. Coolant temperature sensor
14. Cylinder identification sensor
15. Intake air pressure sensor
16. Throttle position sensor
17. Throttle servo motor
18. Accelerator position sensor
19. Intake funnel servo motor

ELECTRICAL COMPONENTS

EAS27980

CHECKING THE SWITCHES

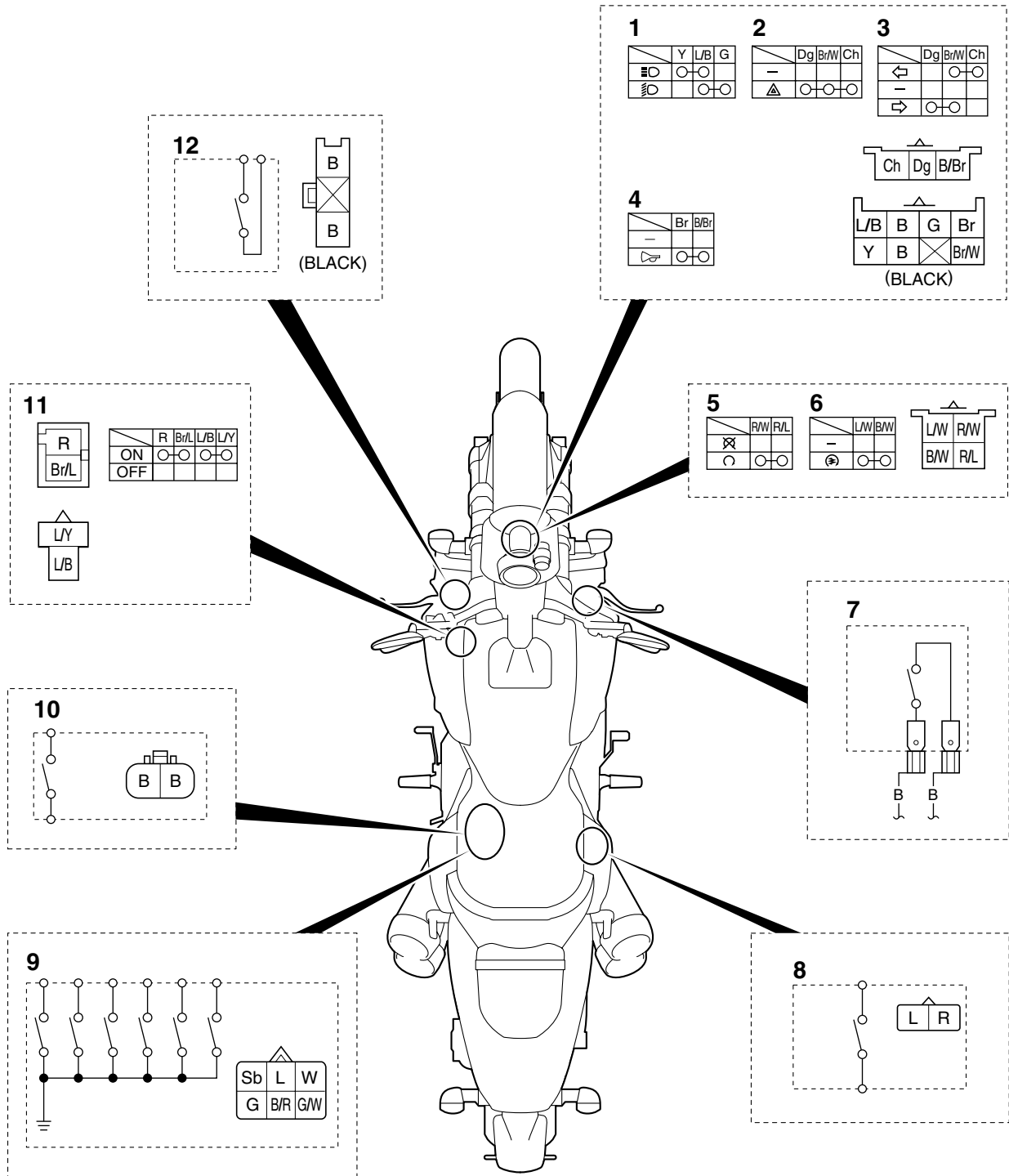

ELECTRICAL COMPONENTS

1. Dimmer switch
2. Hazard switch
3. Turn signal switch
4. Horn switch
5. Engine stop switch
6. Start switch
7. Front brake light switch
8. Rear brake light switch
9. Gear position switch
10. Sidestand switch
11. Main switch
12. Clutch switch

ELECTRICAL COMPONENTS

Check each switch for continuity with the pocket tester. If the continuity reading is incorrect, check the wiring connections and if necessary, replace the switch.

ECA14370

NOTICE

Never insert the tester probes into the coupler terminal slots "a". Always insert the probes from the opposite end of the coupler, taking care not to loosen or damage the leads.



Pocket tester
90890-03112
Analog pocket tester
YU-03112-C

TIP

- Before checking for continuity, set the pocket tester to "0" and to the " $\Omega \times 1$ " range.
- When checking for continuity, switch back and forth between the switch positions a few times.

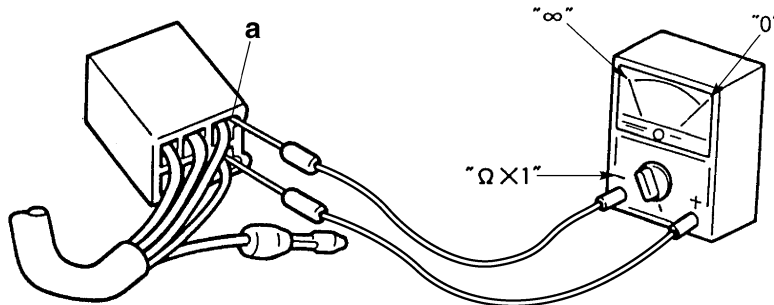

The switches and their terminal connections are illustrated as in the following example of the main switch.

The switch positions "a" are shown in the far left column and the switch lead colors "b" are shown in the top row.

The continuity (i. e., a closed circuit) between switch terminals at a given switch position is indicated by "○—○".

There is continuity between the red and brown/blue leads, and between the blue/black and blue/yellow leads when the switch is set to "ON".

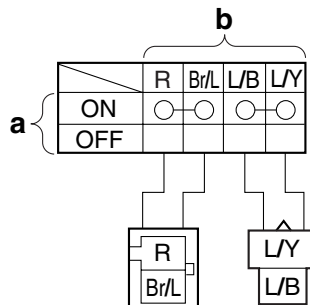

Checking the condition of the bulb sockets

The following procedure applies to all of the bulb sockets.

1. Check:
 - Bulb socket (for continuity) (with the pocket tester)

No continuity → Replace.



Pocket tester
90890-03112
Analog pocket tester
YU-03112-C

TIP

Check each bulb socket for continuity in the same manner as described in the bulb section; however, note the following.

- a. Install a good bulb into the bulb socket.
- b. Connect the pocket tester probes to the respective leads of the bulb socket.
- c. Check the bulb socket for continuity. If any of the readings indicate no continuity, replace the bulb socket.

EAS28000

CHECKING THE FUSES

The following procedure applies to all of the fuses.

ECA2S31051

NOTICE

To avoid a short circuit, always turn the main switch to “OFF” when checking or replacing a fuse.

1. Remove:
 - Right side cover
 - Top cover

Refer to “GENERAL CHASSIS” on page 4-1.
2. Check:
 - Fuse

- a. Connect the pocket tester to the fuse and check the continuity.

TIP

Set the pocket tester selector to “Ω × 1”.



Pocket tester
90890-03112
Analog pocket tester
YU-03112-C

- b. If the pocket tester indicates “∞”, replace the fuse.

3. Replace:

- Blown fuse

- a. Turn the main switch to “OFF”.
- b. Install a new fuse of the correct amperage rating.
- c. Set on the switches to verify if the electrical circuit is operational.
- d. If the fuse immediately blows again, check the electrical circuit.

Fuses	Amperage rating	Q'ty
Main	50 A	1
ABS motor	30 A	1
Ignition	20 A	1
Main radiator fan motor	20 A	1
Fuel injection system	15 A	1
ABS solenoid	15 A	1
Signaling system	15 A	1
Headlight	15 A	1
Electric throttle valve	7.5 A	1
Backup (odometer and clock)	7.5 A	1
ABS ECU	7.5 A	1
Sub radiator fan motor	7.5 A	1
Spare	30 A	1
Spare	20 A	1
Spare	15 A	2
Spare	7.5 A	1

EWA13310



Never use a fuse with an amperage rating other than that specified. Improvising or using a fuse with the wrong amperage rating may cause extensive damage to the electrical system, cause the lighting and ignition systems to malfunction and could possibly cause a fire.

4. Install:

- Top cover
- Right side cover

Refer to “GENERAL CHASSIS” on page 4-1.

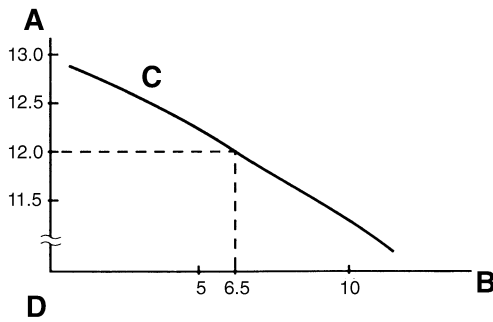

- A. Open-circuit voltage (V)
 B. Charging time (hours)
 C. Relationship between the open-circuit voltage and the charging time at 20 °C (68 °F)
 D. These values vary with the temperature, the condition of the battery plates, and the electrolyte level.

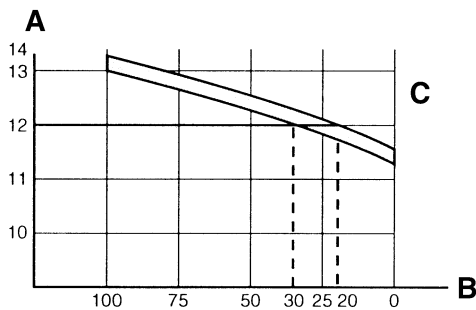

- A. Open-circuit voltage (V)
 B. Charging condition of the battery (%)
 C. Ambient temperature 20 °C (68 °F)



5. Charge:

- Battery (refer to the appropriate charging method)

EWA13300



Do not quick charge a battery.

ECA2S31053

NOTICE

- Do not use a high-rate battery charger since it forces a high-amperage current into the battery quickly and can cause battery overheating and battery plate damage.
- If it is impossible to regulate the charging current on the battery charger, be careful not to overcharge the battery.
- When charging a battery, be sure to remove it from the vehicle. (If charging has to be done with the battery mounted on the vehicle, disconnect the negative battery lead from the battery terminal.)

- To reduce the chance of sparks, do not plug in the battery charger until the battery charger leads are connected to the battery.
- Before removing the battery charger lead clips from the battery terminals, be sure to turn off the battery charger.
- Make sure the battery charger lead clips are in full contact with the battery terminal and that they are not shorted. A corroded battery charger lead clip may generate heat in the contact area and a weak clip spring may cause sparks.
- If the battery becomes hot to the touch at any time during the charging process, disconnect the battery charger and let the battery cool before reconnecting it. Hot batteries can explode!
- As shown in the following illustration, the open-circuit voltage of a VRLA (Valve Regulated Lead Acid) battery stabilizes about 30 minutes after charging has been completed. Therefore, wait 30 minutes after charging is completed before measuring the open-circuit voltage.

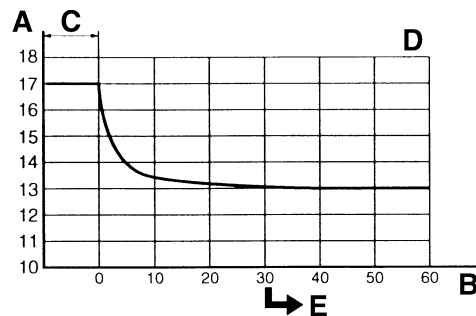

- A. Open-circuit voltage (V)
 B. Time (minutes)
 C. Charging
 D. Ambient temperature 20 °C (68 °F)
 E. Check the open-circuit voltage.

Charging method using a variable-current (voltage) charger

- Measure the open-circuit voltage prior to charging.

TIP

Voltage should be measured 30 minutes after the engine is stopped.

- Connect a charger and ammeter to the battery and start charging.

TIP

Set the charging voltage to 16–17 V. If the setting is lower, charging will be insufficient. If too high, the battery will be over-charged.

- c. Make sure that the current is higher than the standard charging current written on the battery.

TIP

If the current is lower than the standard charging current written on the battery, set the charging voltage adjust dial at 20–24 V and monitor the amperage for 3–5 minutes to check the battery.

- Standard charging current is reached
Battery is good.
- Standard charging current is not reached
Replace the battery.

- d. Adjust the voltage so that the current is at the standard charging level.
- e. Set the time according to the charging time suitable for the open-circuit voltage.
- f. If charging requires more than 5 hours, it is advisable to check the charging current after a lapse of 5 hours. If there is any change in the amperage, readjust the voltage to obtain the standard charging current.
- g. Measure the battery open-circuit voltage after leaving the battery unused for more than 30 minutes.

12.8 V or more --- Charging is complete.
12.7 V or less --- Recharging is required.
Under 12.0 V --- Replace the battery.



Charging method using a constant voltage charger

- a. Measure the open-circuit voltage prior to charging.

TIP

Voltage should be measured 30 minutes after the engine is stopped.

- b. Connect a charger and ammeter to the battery and start charging.
- c. Make sure that the current is higher than the standard charging current written on the battery.

TIP

If the current is lower than the standard charging current written on the battery, this type of battery charger cannot charge the VRLA (Valve Regulated Lead Acid) battery. A variable voltage charger is recommended.

- d. Charge the battery until the battery's charging voltage is 15 V.

TIP

Set the charging time at 20 hours (maximum).

- e. Measure the battery open-circuit voltage after leaving the battery unused for more than 30 minutes.

12.8 V or more --- Charging is complete.
12.7 V or less --- Recharging is required.
Under 12.0 V --- Replace the battery.



- 6. Install:
 - Battery
Refer to "GENERAL CHASSIS" on page 4-1.
- 7. Connect:
 - Battery leads
(to the battery terminals)

ECA13630

NOTICE

First, connect the positive battery lead "1", and then the negative battery lead "2".

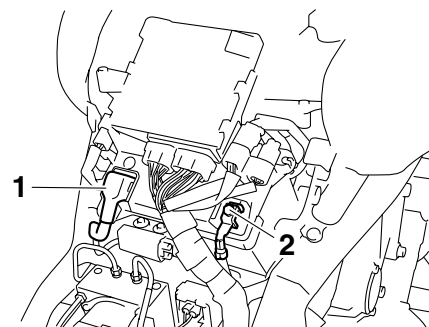

- 8. Check:
 - Battery terminals
Dirt → Clean with a wire brush.
Loose connection → Connect properly.
- 9. Lubricate:
 - Battery terminals

	<p>Recommended lubricant Dielectric grease</p>
---	--

- 10. Install:
 - Top cover
Refer to "GENERAL CHASSIS" on page 4-1.

EAS28040

CHECKING THE RELAYS

Check each switch for continuity with the pocket tester. If the continuity reading is incorrect, replace the relay.



Pocket tester
90890-03112
Analog pocket tester
YU-03112-C

1. Disconnect the relay from the wire harness.
2. Connect the pocket tester ($\Omega \times 1$) and battery (12 V) to the relay terminal as shown. Check the relay operation. Out of specification → Replace.

Starter relay

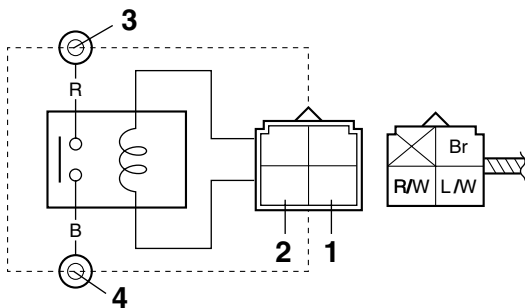

1. Positive battery terminal
2. Negative battery terminal
3. Positive tester probe
4. Negative tester probe



Result
Continuity
(between “3” and “4”)

Relay unit (starting circuit cut-off relay)

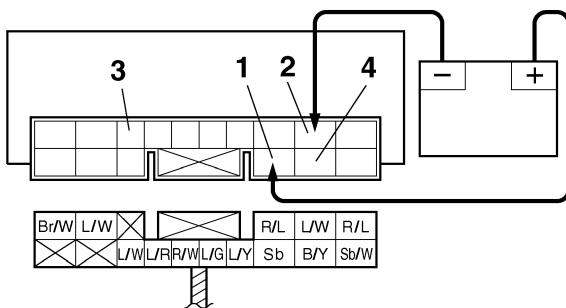

1. Positive battery terminal
2. Negative battery terminal
3. Positive tester probe
4. Negative tester probe

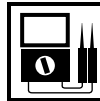

Result
Continuity
(between “3” and “4”)

Relay unit (fuel pump relay)

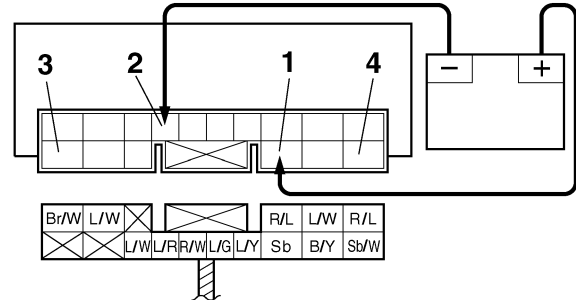

1. Positive battery terminal
2. Negative battery terminal
3. Positive tester probe
4. Negative tester probe

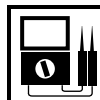

Result
Continuity
(between “3” and “4”)

Headlight relay

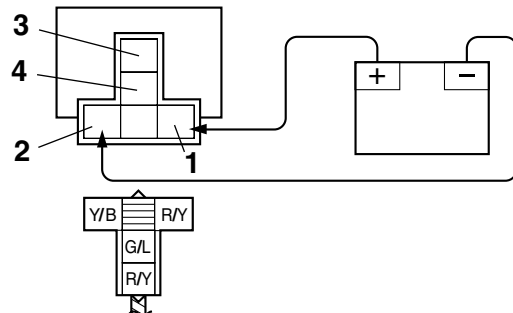

1. Positive battery terminal
2. Negative battery terminal
3. Positive tester probe
4. Negative tester probe

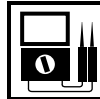

Result
Continuity
(between “3” and “4”)

Radiator fan motor relay

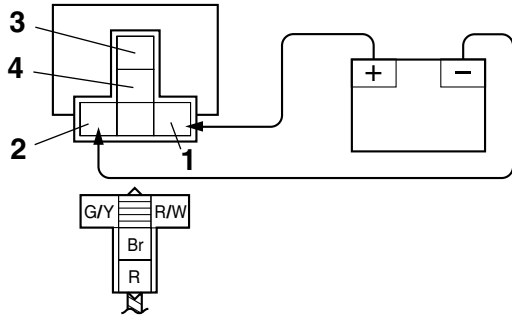

1. Positive battery terminal
2. Negative battery terminal
3. Positive tester probe
4. Negative tester probe

Result
Continuity
(between “3” and “4”)

EAS2S31059

CHECKING THE TURN SIGNAL/HAZARD RELAY

1. Check:
 - Turn signal/hazard relay input voltage
Out of specification → The wiring circuit from the main switch to the turn signal/hazard relay coupler is faulty and must be repaired.

Turn signal/hazard relay input voltage
DC 12 V

- a. Connect the pocket tester (DC 20 V) to the turn signal/hazard relay terminal as shown.

Pocket tester
90890-03112
Analog pocket tester
YU-03112-C

- Positive tester probe → brown/black “1”
- Negative tester probe → ground

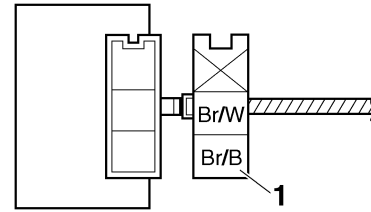

- b. Turn the main switch to “ON”.
- c. Measure the turn signal/hazard relay input voltage.



2. Check:
 - Turn signal/hazard relay output voltage
Out of specification → Replace.

Turn signal/hazard relay output voltage
DC 12 V



- a. Connect the pocket tester (DC 20 V) to the turn signal/hazard relay terminal as shown.

Pocket tester
90890-03112
Analog pocket tester
YU-03112-C

- Positive tester probe → brown/white “1”
- Negative tester probe → ground

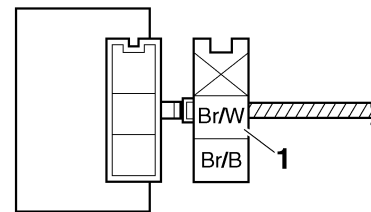

- b. Turn the main switch to “ON”.
- c. Measure the turn signal/hazard relay output voltage.



EAS28050

CHECKING THE RELAY UNIT (DIODE)

1. Check:
 - Relay unit (diode)
Out of specification → Replace.

c. Measure the primary coil resistance.

2. Check:

- Secondary coil resistance
Out of specification → Replace.



Secondary coil resistance
8.50–11.50 kΩ

a. Disconnect the spark plug cap from the ignition coil.

b. Connect the pocket tester ($\Omega \times 1k$) to the ignition coil as shown.



Pocket tester
90890-03112
Analog pocket tester
YU-03112-C

- Negative tester probe → black/orange “1”
- Positive tester probe → spark plug terminal “2”

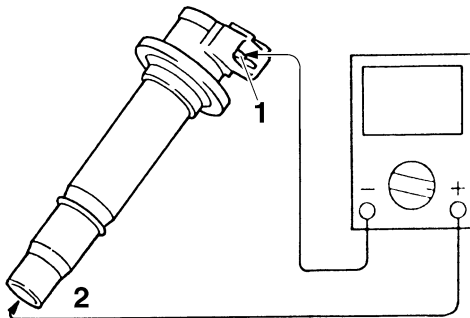

c. Measure the secondary coil resistance.

CHECKING THE IGNITION SPARK GAP

1. Check:

- Ignition spark gap
Out of specification → Perform the ignition system troubleshooting, starting with step 5. Refer to “TROUBLESHOOTING” on page 8-4.



Minimum ignition spark gap
6.0 mm (0.24 in)

TIP

If the ignition spark gap is within specification, the ignition system circuit is operating normally.

a. Disconnect the spark plug cap from the spark plug.

b. Connect the ignition checker “1” as shown.



Ignition checker
90890-06754
Opama pet-4000 spark checker
YM-34487

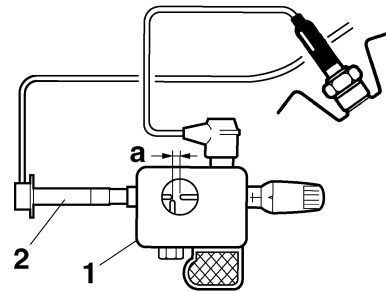

2. Ignition coil

c. Turn the main switch to “ON” and engine stop switch to “O”.

d. Measure the ignition spark gap “a”.

e. Crank the engine by pushing the start switch “⊕” and gradually increase the spark gap until a misfire occurs.

EAS28120

CHECKING THE CRANKSHAFT POSITION SENSOR

1. Disconnect:

- Crankshaft position sensor coupler (from the wire harness)

2. Check:

- Crankshaft position sensor resistance
Out of specification → Replace the crankshaft position sensor.



Crankshaft position sensor resistance
192–288 Ω at 20 °C (68 °F)

a. Connect the pocket tester ($\Omega \times 100$) to the crankshaft position sensor coupler as shown.



Pocket tester
90890-03112
Analog pocket tester
YU-03112-C

- Positive tester probe → blue/yellow “1”
- Negative tester probe → green/white “2”

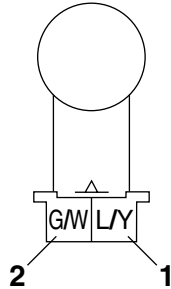

- b. Measure the crankshaft position sensor resistance.



EAS28130

CHECKING THE LEAN ANGLE SENSOR

1. Remove:
 - Lean angle sensor
2. Check:
 - Lean angle sensor output voltage
Out of specification → Replace.



Lean angle sensor output voltage
 Less than 65°: 0.4–1.4 V
 More than 65°: 3.7–4.4 V

- a. Connect the lean angle sensor coupler to the wire harness.
- b. Connect the pocket tester (DC 20 V) to the lean angle sensor coupler as shown.



Pocket tester
 90890-03112
Analog pocket tester
 YU-03112-C

- Positive tester probe → yellow/green “1”
- Negative tester probe → black/blue “2”

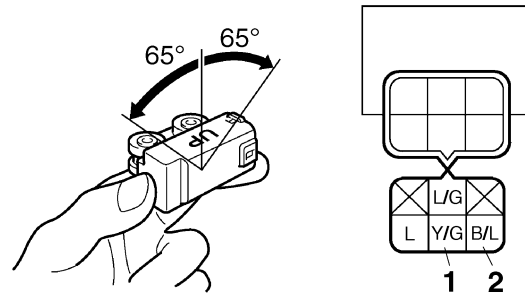

- c. Turn the main switch to “ON”.
- d. Turn the lean angle sensor to 65°.
- e. Measure the lean angle sensor output voltage.



EAS28940

CHECKING THE STARTER MOTOR OPERATION

1. Check:
 - Starter motor operation
Does not operate → Perform the electric starting system troubleshooting, starting with step 4.
Refer to “TROUBLESHOOTING” on page 8-10.



- a. Connect the positive battery terminal “1” and starter motor lead “2” with a jumper lead “3”.

EWA13810

⚠ WARNING

- A wire that is used as a jumper lead must have at least the same capacity of the battery lead, otherwise the jumper lead may burn.
- This check is likely to produce sparks, therefore, make sure no flammable gas or fluid is in the vicinity.

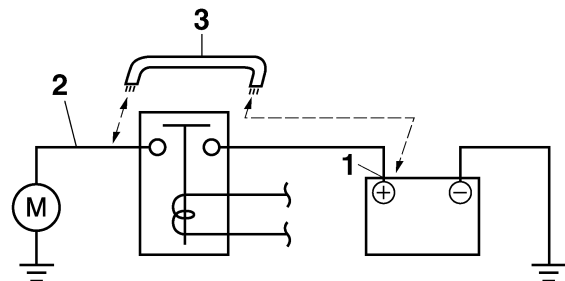

- b. Check the starter motor operation.



EAS28150

CHECKING THE STATOR COIL

1. Disconnect:
 - Stator coil coupler (from the wire harness)
2. Check:
 - Stator coil resistance
 Out of specification → Replace the stator coil.



Stator coil resistance
0.184–0.276 Ω at 20 °C (68 °F)

- a. Connect the pocket tester ($\Omega \times 1$) to the stator coil coupler as shown.



Pocket tester
90890-03112
Analog pocket tester
YU-03112-C

- Positive tester probe → white “1”
- Negative tester probe → white “2”

- Positive tester probe → white “1”
- Negative tester probe → white “3”

- Positive tester probe → white “2”
- Negative tester probe → white “3”

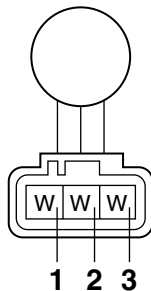

- b. Measure the stator coil resistance.

EAS28170

CHECKING THE RECTIFIER/REGULATOR

1. Check:
 - Charging voltage
 Out of specification → Replace the rectifier/regulator.



Charging voltage
14 V at 5000 r/min

- a. Set the engine tachometer to the spark plug lead of cylinder #1.
- b. Connect the pocket tester (DC 20 V) to the rectifier/regulator coupler as shown.



Pocket tester
90890-03112
Analog pocket tester
YU-03112-C

- Positive tester probe → red “1”
- Negative tester probe → black “2”

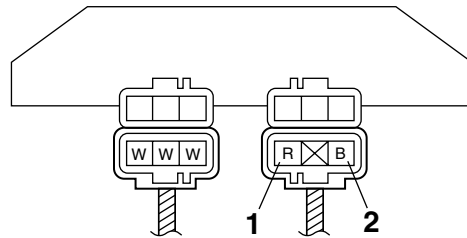

- c. Start the engine and let it run at approximately 5000 r/min.
- d. Measure the charging voltage.

EAS28180

CHECKING THE HORN

1. Check:
 - Horn sound
 Faulty sound → Adjust or replace.

- a. Connect a battery (12 V) to the horn.
- b. Turn the adjusting screw in direction “a” or “b” until the horn sound is obtained.

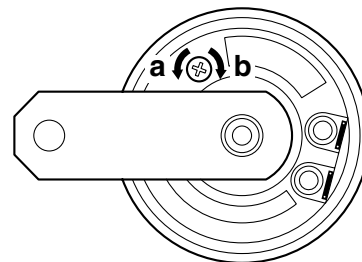

EAS28190

CHECKING THE OIL LEVEL SWITCH

1. Drain:
 - Engine oil
2. Remove:
 - Oil level switch
(from the oil pan)
3. Check:
 - Oil level switch resistance



Oil level switch resistance
Maximum level position
 484–536 Ω
Minimum level position
 114–126 Ω

- a. Connect the pocket tester ($\Omega \times 100$) to the oil level switch terminal as shown.



Pocket tester
 90890-03112
Analog pocket tester
 YU-03112-C

Maximum level position "A"

- Positive tester probe → connector (white) "1"
- Negative tester probe → body ground "2"

Minimum level position "B"

- Positive tester probe → connector (white) "1"
- Negative tester probe → body ground "2"

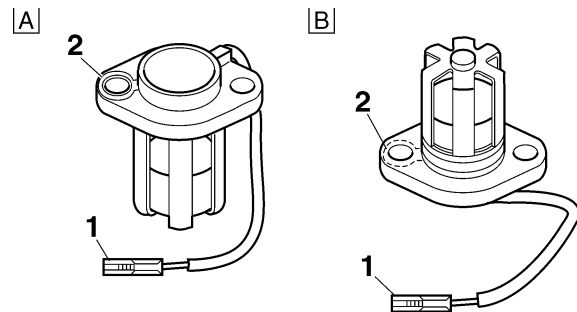

- b. Measure the oil level switch resistance.

EAS28220

CHECKING THE FUEL SENDER

1. Disconnect:
 - Fuel pump coupler
(from the wire harness)

2. Remove:
 - Fuel pump
(from the fuel tank)
3. Check:
 - Fuel sender resistance
Out of specification → Replace the fuel pump assembly.



Sender unit resistance (full)
 19.0–21.0 Ω
Sender unit resistance (empty)
 139.0–141.0 Ω

- a. Connect the pocket tester ($\Omega \times 10$) to the fuel sender terminals as shown.



Pocket tester
 90890-03112
Analog pocket tester
 YU-03112-C

- Positive tester probe → green/black "1"
- Negative tester probe → black "2"

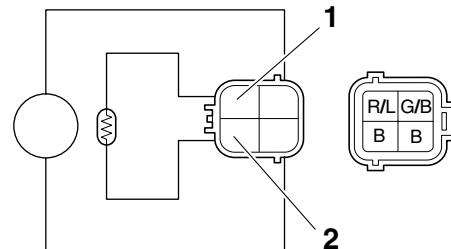

- b. Move the fuel sender float to minimum "3" and maximum "4" level position.

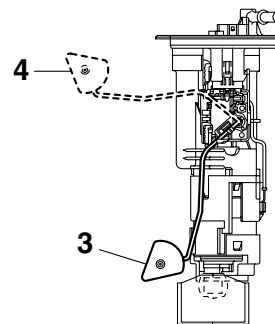

- c. Measure the fuel sender resistance.

EAS29040

CHECKING THE FUEL LEVEL WARNING LIGHT

This model is equipped with a self-diagnosis device for the fuel level detection circuit.

1. Check:

- Fuel level warning light “1”
(Turn the main switch to “ON”.)
Warning light comes on for a few seconds, then goes off → Warning light is OK.
Warning light does not come on → Replace the meter assembly 1.
- Warning light flashes eight times, then goes off for three seconds in a repeated cycle (malfunction detected in fuel sender or thermistor) → Replace the fuel pump assembly.

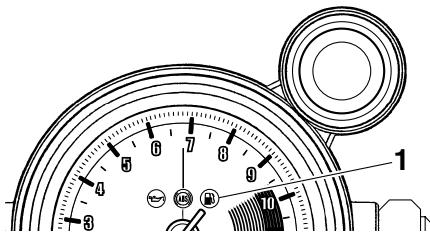

EAS29050

CHECKING THE OIL LEVEL WARNING LIGHT

This model is equipped with a self-diagnosis device for the oil level detection circuit.

1. Check:

- Oil level warning light “1”
(Turn the main switch to “ON”.)
Warning light comes on for a few seconds, then goes off → Warning light is OK.
Warning light does not come on → Replace the meter assembly 1.
- Warning light flashes ten times, then goes off for 2.5 seconds in a repeated cycle (malfunction detected in oil level switch) → Replace the oil level switch.

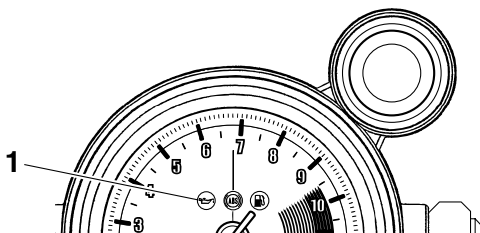

EAS28250

CHECKING THE RADIATOR FAN MOTORS

The following procedure applies to both of the radiator fan motors.

1. Check:

- Radiator fan motor
Faulty/rough movement → Replace.



- a. Disconnect the radiator fan motor coupler from the wire harness.
- b. Connect the battery (DC 12 V) as shown.

- Positive battery terminal → blue “1”
- Negative battery terminal → black “2”

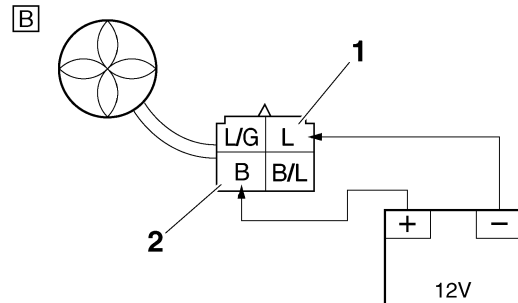
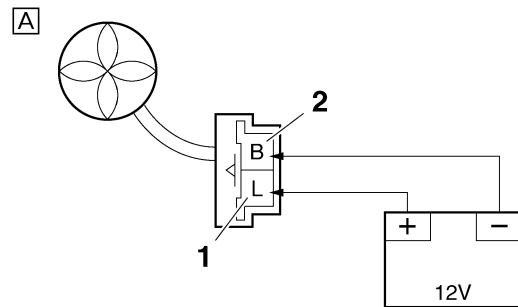

- A. Sub radiator fan motor
B. Main radiator fan motor

c. Measure the radiator fan motor movement.



EAS28260

CHECKING THE COOLANT TEMPERATURE SENSOR

1. Remove:

- Coolant temperature sensor
Refer to “CYLINDER HEADS” on page 5-26.

EWA14130

⚠ WARNING

- Handle the coolant temperature sensor with special care.
- Never subject the coolant temperature sensor to strong shocks. If the coolant temperature sensor is dropped, replace it.

EAS29100

CHECKING THE ACCELERATOR POSITION SENSOR

- Remove:
 - Accelerator position sensor (from the throttle body)

EWA2S31017

WARNING

- Handle the accelerator position sensor with special care.
- Never subject the accelerator position sensor to strong shocks. If the accelerator position sensor is dropped, replace it.

2. Check:

- Accelerator position sensor maximum resistance
Out of specification → Replace the accelerator position sensor.

	Resistance 1.2–2.8 kΩ
---	---------------------------------

- Connect the pocket tester ($\Omega \times 1k$) to the accelerator position sensor terminals as shown.

	Pocket tester 90890-03112 Analog pocket tester YU-03112-C
--	--

- Positive tester probe → blue/green “1”
- Negative tester probe → black/brown “2”

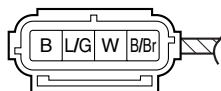
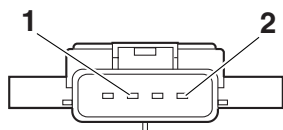

- Measure the accelerator position sensor maximum resistance.



3. Install:

- Accelerator position sensor

TIP

When installing the accelerator position sensor, adjust its angle properly. Refer to “ADJUSTING THE ACCELERATOR POSITION SENSOR” on page 7-17.

EAS28370

CHECKING THE AIR INDUCTION SYSTEM SOLENOID

- Check:
 - Air induction system solenoid resistance
Out of specification → Replace.

	Solenoid resistance 20–23 Ω at 20 °C (68 °F)
---	---

- Disconnect the air induction system solenoid coupler from the wire harness.
- Connect the pocket tester ($\Omega \times 1$) to the air induction system solenoid terminals as shown.

	Pocket tester 90890-03112 Analog pocket tester YU-03112-C
---	--

- Positive tester probe → red/white “1”
- Negative tester probe → brown/red “2”

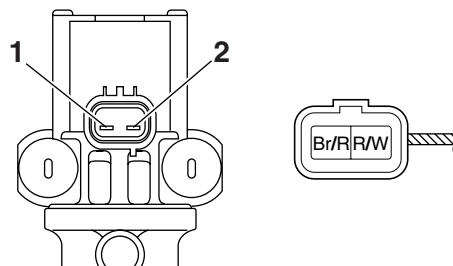

- Measure the air induction system solenoid resistance.



CHECKING THE ATMOSPHERIC PRESSURE SENSOR

EWA2S31018

WARNING

- Handle the atmospheric pressure sensor with special care.

TROUBLESHOOTING

TROUBLESHOOTING	9-1
GENERAL INFORMATION	9-1
STARTING FAILURES.....	9-1
INCORRECT ENGINE IDLING SPEED	9-1
POOR MEDIUM-AND-HIGH-SPEED PERFORMANCE	9-2
FAULTY GEAR SHIFTING.....	9-2
SHIFT PEDAL DOES NOT MOVE	9-2
JUMPS OUT OF GEAR.....	9-2
FAULTY CLUTCH	9-2
OVERHEATING	9-3
OVERCOOLING.....	9-3
POOR BRAKING PERFORMANCE.....	9-3
FAULTY FRONT FORK LEGS.....	9-3
UNSTABLE HANDLING	9-3
FAULTY LIGHTING OR SIGNALING SYSTEM.....	9-4

EAS28451

TROUBLESHOOTING

EAS28460

GENERAL INFORMATION

TIP

The following guide for troubleshooting does not cover all the possible causes of trouble. It should be helpful, however, as a guide to basic troubleshooting. Refer to the relative procedure in this manual for checks, adjustments, and replacement of parts.

EAS28470

STARTING FAILURES

Engine

1. Cylinder(s) and cylinder head(s)
 - Loose spark plug
 - Loose cylinder head
 - Damaged cylinder head gasket
 - Worn or damaged cylinder
 - Incorrect valve clearance
 - Improperly sealed valve
 - Incorrect valve-to-valve-seat contact
 - Incorrect valve timing
 - Faulty valve spring
 - Seized valve
2. Piston(s) and piston ring(s)
 - Improperly installed piston ring
 - Damaged, worn or fatigued piston ring
 - Seized piston ring
 - Seized or damaged piston
3. Air filter
 - Improperly installed air filter
 - Clogged air filter element
4. Crankcase and crankshaft
 - Improperly assembled crankcase
 - Seized crankshaft

Fuel system

1. Fuel tank
 - Empty fuel tank
 - Clogged fuel overflow hose
 - Clogged rollover valve
 - Clogged fuel tank breather hose
 - Deteriorated or contaminated fuel
2. Fuel pump
 - Faulty fuel pump
 - Faulty fuel pump relay
3. Throttle body(-ies)
 - Deteriorated or contaminated fuel
 - Sucked-in air

Electrical system

1. Battery
 - Discharged battery
 - Faulty battery
2. Fuse(s)
 - Blown, damaged or incorrect fuse
 - Improperly installed fuse
3. Spark plug(s)
 - Incorrect spark plug gap
 - Incorrect spark plug heat range
 - Fouled spark plug
 - Worn or damaged electrode
 - Worn or damaged insulator
4. Ignition coil(s)
 - Cracked or broken ignition coil body
 - Broken or shorted primary or secondary coils
5. Ignition system
 - Faulty ECU
 - Faulty crankshaft position sensor
 - Faulty cylinder identification sensor
 - Broken generator rotor woodruff key
6. Switches and wiring
 - Faulty main switch
 - Faulty engine stop switch
 - Broken or shorted wiring
 - Faulty gear position switch
 - Faulty start switch
 - Faulty sidestand switch
 - Faulty clutch switch
 - Improperly grounded circuit
 - Loose connections
7. Starting system
 - Faulty starter motor
 - Faulty starter relay
 - Faulty starting circuit cut-off relay
 - Faulty starter clutch

EAS28490

INCORRECT ENGINE IDLING SPEED

Engine

1. Cylinder(s) and cylinder head(s)
 - Incorrect valve clearance
 - Damaged valve train components
2. Air filter
 - Clogged air filter element

Fuel system

1. Throttle body(-ies)
 - Damaged or loose throttle body joint
 - Improperly synchronized throttle bodies
 - Improper throttle cable free play
 - Flooded throttle body
 - Faulty air induction system

Electrical system

1. Battery
 - Discharged battery
 - Faulty battery
2. Spark plug(s)
 - Incorrect spark plug gap
 - Incorrect spark plug heat range
 - Fouled spark plug
 - Worn or damaged electrode
 - Worn or damaged insulator
3. Ignition coil(s)
 - Broken or shorted primary or secondary coils
 - Cracked or broken ignition coil
4. Ignition system
 - Faulty ECU
 - Faulty crankshaft position sensor
 - Faulty cylinder identification sensor
 - Broken generator rotor woodruff key

EAS28520

POOR MEDIUM-AND-HIGH-SPEED PERFORMANCE

Refer to “STARTING FAILURES” on page 9-1.

Engine

1. Air filter
 - Clogged air filter element

Fuel system

1. Fuel pump
 - Faulty fuel pump

EAS28530

FAULTY GEAR SHIFTING

Shifting is difficult

Refer to “Clutch drags”.

EAS28540

SHIFT PEDAL DOES NOT MOVE

Shift shaft

- Improperly adjusted shift rod
- Bent shift shaft

Shift drum and shift forks

- Foreign object in a shift drum groove
- Seized shift fork
- Bent shift fork guide bar

Transmission

- Seized transmission gear
- Foreign object between transmission gears
- Improperly assembled transmission

EAS28550

JUMPS OUT OF GEAR

Shift shaft

- Incorrect shift pedal position
- Improperly returned stopper lever

Shift forks

- Worn shift fork

Shift drum

- Incorrect axial play
- Worn shift drum groove

Transmission

- Worn gear dog

EAS28570

FAULTY CLUTCH

Clutch slips

1. Clutch
 - Improperly assembled clutch
 - Improperly assembled clutch master cylinder
 - Improperly assembled clutch release cylinder
 - Incorrect clutch fluid level
 - Damaged clutch hose
 - Loose or fatigued clutch spring
 - Loose union bolt
 - Worn friction plate
 - Worn clutch plate
 - Damaged clutch release cylinder
2. Engine oil
 - Incorrect oil level
 - Incorrect oil viscosity (low)
 - Deteriorated oil

Clutch drags

1. Clutch
 - Air in hydraulic clutch system
 - Unevenly tensioned clutch springs
 - Warped pressure plate
 - Bent clutch plate
 - Swollen friction plate
 - Bent clutch push rod
 - Damaged clutch boss
 - Burnt primary driven gear bushing
 - Damaged clutch release cylinder
 - Match marks not aligned
2. Engine oil
 - Incorrect oil level
 - Incorrect oil viscosity (high)
 - Deteriorated oil

EAS28600

OVERHEATING

Engine

1. Clogged coolant passages
 - Cylinder head(s) and piston(s)
 - Heavy carbon buildup
2. Engine oil
 - Incorrect oil level
 - Incorrect oil viscosity
 - Inferior oil quality

Cooling system

1. Coolant
 - Low coolant level
2. Radiator
 - Damaged or leaking radiator
 - Faulty radiator cap
 - Bent or damaged radiator fin
3. Water pump
 - Damaged or faulty water pump
 - Thermostat
 - Thermostat stays closed
 - Oil cooler
 - Clogged or damaged oil cooler
 - Hose(s) and pipe(s)
 - Damaged hose
 - Improperly connected hose
 - Damaged pipe
 - Improperly connected pipe

Fuel system

1. Throttle body(-ies)
 - Damaged or loose throttle body joint
2. Air filter
 - Clogged air filter element

Chassis

1. Brake(s)
 - Dragging brake

Electrical system

1. Spark plug(s)
 - Incorrect spark plug gap
 - Incorrect spark plug heat range
2. Ignition system
 - Faulty ECU

EAS28610

OVERCOOLING

Cooling system

1. Thermostat
 - Thermostat stays open

EAS28620

POOR BRAKING PERFORMANCE

- Worn brake pad
- Worn brake disc
- Air in hydraulic brake system
- Leaking brake fluid
- Faulty brake caliper kit
- Faulty brake caliper seal
- Loose union bolt
- Damaged brake hose
- Oil or grease on the brake disc
- Oil or grease on the brake pad
- Incorrect brake fluid level

EAS28660

FAULTY FRONT FORK LEGS

Leaking oil

- Bent, damaged or rusty inner tube
- Cracked or damaged outer tube
- Improperly installed oil seal
- Damaged oil seal lip
- Incorrect oil level (high)
- Loose damper rod assembly bolt
- Damaged damper rod assembly bolt copper washer
- Cracked or damaged cap bolt O-ring

Malfunction

- Bent or damaged inner tube
- Bent or damaged outer tube
- Damaged fork spring
- Worn or damaged outer tube bushing
- Bent or damaged damper rod
- Incorrect oil viscosity
- Incorrect oil level

EAS28670

UNSTABLE HANDLING

1. Handlebar
 - Bent or improperly installed handlebar
2. Steering head components
 - Improperly installed upper bracket
 - Improperly installed lower bracket (improperly tightened ring nut)
 - Bent steering stem
 - Damaged roller bearing or bearing race
3. Front fork leg(s)
 - Uneven oil levels (both front fork legs)
 - Unevenly tensioned fork spring (both front fork legs)
 - Broken fork spring
 - Bent or damaged inner tube
 - Bent or damaged outer tube

4. Swingarm
 - Worn bearing or bushing
 - Bent or damaged swingarm
5. Rear shock absorber assembly(-ies)
 - Faulty rear shock absorber spring
 - Leaking oil or gas
6. Tire(s)
 - Uneven tire pressures (front and rear)
 - Incorrect tire pressure
 - Uneven tire wear
7. Wheel(s)
 - Incorrect wheel balance
 - Deformed cast wheel
 - Damaged wheel bearing
 - Bent or loose wheel axle
 - Excessive wheel runout
8. Frame
 - Bent frame
 - Damaged steering head pipe
 - Improperly installed bearing race

EAS28710

FAULTY LIGHTING OR SIGNALING SYSTEM

Headlight does not come on

- Wrong headlight bulb
- Too many electrical accessories
- Hard charging
- Incorrect connection
- Improperly grounded circuit
- Poor contacts (main switch)
- Burnt-out headlight bulb

Headlight bulb burnt out

- Wrong headlight bulb
- Faulty battery
- Faulty rectifier/regulator
- Improperly grounded circuit
- Faulty main switch
- Headlight bulb life expired

Tail/brake light does not come on

- Wrong tail/brake light LED
- Too many electrical accessories
- Incorrect connection
- Burnt-out tail/brake light LED

Tail/brake light bulb burnt out

- Wrong tail/brake light LED
- Faulty battery
- Incorrectly adjusted rear brake light switch
- Tail/brake light LED life expired

Turn signal does not come on

- Faulty turn signal switch
- Faulty turn signal/hazard relay
- Burnt-out turn signal bulb
- Incorrect connection
- Damaged or faulty wire harness
- Improperly grounded circuit
- Faulty battery
- Blown, damaged or incorrect fuse

Turn signal blinks slowly

- Faulty turn signal/hazard relay
- Faulty main switch
- Faulty turn signal switch
- Incorrect turn signal bulb

Turn signal remains lit

- Faulty turn signal/hazard relay
- Burnt-out turn signal bulb

Turn signal blinks quickly

- Incorrect turn signal bulb
- Faulty turn signal/hazard relay
- Burnt-out turn signal bulb

Horn does not sound

- Improperly adjusted horn
- Damaged or faulty horn
- Faulty main switch
- Faulty horn switch
- Faulty battery
- Blown, damaged or incorrect fuse
- Faulty wire harness

WIRING DIAGRAM**VMX17Y(C) 2009**

1. AC magneto
2. Rectifier/regulator
3. Fuel injection system fuse
4. ABS solenoid fuse
5. Electric throttle valve fuse
6. Main fuse
7. Main switch
8. Battery
9. Frame ground
10. Backup fuse (odometer and clock)
11. ABS motor fuse
12. Starter relay
13. Starter motor
14. Relay unit
15. Starting circuit cut-off relay
16. Fuel pump relay
17. Fuel pump
18. Fuel sender
19. Sidestand switch
20. Crankshaft position sensor
21. Atmospheric pressure sensor
22. Intake air pressure sensor
23. Cylinder identification sensor
24. Lean angle sensor
25. O₂ sensor
26. Coolant temperature sensor
27. Intake air temperature sensor
28. Accelerator position sensor
29. Throttle position sensor
30. ECU (engine control unit)
31. Air induction system solenoid
32. Cylinder-#1 ignition coil
33. Cylinder-#2 ignition coil
34. Cylinder-#3 ignition coil
35. Cylinder-#4 ignition coil
36. Spark plug
37. Throttle servo motor
38. Intake funnel servo motor
39. EXUP servo motor
40. Injector #1
41. Injector #2
42. Injector #3
43. Injector #4
44. Rear wheel sensor
45. Front wheel sensor
46. ABS test coupler
47. ABS ECU (electronic control unit)
48. SELECT/RESET button unit
49. Meter assembly 1
50. Neutral indicator light
51. ABS warning light
52. Shift timing indicator light
53. Multi-function meter
54. Oil level warning light

55. Engine trouble warning light
56. Fuel level warning light
57. Coolant temperature warning light
58. Meter light
59. Left turn signal indicator light
60. Right turn signal indicator light
61. High beam indicator light
62. Meter assembly 2
63. Gear position switch
64. Oil level switch
65. Turn signal/hazard relay
66. Headlight relay
67. Left handlebar switch
68. Clutch switch
69. Dimmer switch
70. Hazard switch
71. Turn signal switch
72. Horn switch
73. Rear right turn signal light
74. Rear left turn signal light
75. Horn
76. Front right turn signal/position light
77. Front left turn signal/position light
78. Headlight assembly
79. Auxiliary light
80. Headlight
81. Right handlebar switch
82. Front brake light switch
83. Engine stop switch
84. Start switch
85. Tail/brake light
86. Rear brake light switch
87. License plate light
88. Signaling system fuse
89. Ignition fuse
90. Headlight fuse
91. ABS ECU fuse
92. Radiator fan motor relay
93. Main radiator fan motor fuse
94. Main radiator fan motor
95. Sub radiator fan motor fuse
96. Sub radiator fan motor

COLOR CODE

B	Black
Br	Brown
Ch	Chocolate
Dg	Dark green
G	Green
Gy	Gray
L	Blue
Lg	Light green
O	Orange
P	Pink
R	Red
Sb	Sky blue
W	White
Y	Yellow
B/Br	Black/Brown
B/G	Black/Green
B/L	Black/Blue
B/O	Black/Orange
B/R	Black/Red
B/W	Black/White
B/Y	Black/Yellow
Br/B	Brown/Black
Br/L	Brown/Blue
Br/R	Brown/Red
Br/W	Brown/White
Br/Y	Brown/Yellow
G/B	Green/Black
G/L	Green/Blue
G/O	Green/Orange
G/R	Green/Red
G/W	Green/White
G/Y	Green/Yellow
Gy/B	Gray/Black
Gy/G	Gray/Green
Gy/R	Gray/Red
L/B	Blue/Black
L/G	Blue/Green
L/R	Blue/Red
L/W	Blue/White
L/Y	Blue/Yellow
Lg/L	Light green/Blue
Lg/W	Light green/White
O/B	Orange/Black
O/G	Orange/Green
O/R	Orange/Red
O/W	Orange/White
O/Y	Orange/Yellow
P/B	Pink/Black
P/W	Pink/White
R/B	Red/Black
R/G	Red/Green
R/L	Red/Blue
R/W	Red/White
R/Y	Red/Yellow
Sb/W	Sky blue/White
W/B	White/Black
W/L	White/Blue
W/R	White/Red
W/Y	White/Yellow
Y/B	Yellow/Black
Y/G	Yellow/Green
Y/L	Yellow/Blue
Y/R	Yellow/Red
Y/W	Yellow/White



YAMAHA MOTOR CO., LTD.
2500 SHINGAI IWATA SHIZUOKA JAPAN

VMX17Y(C) 2009 WIRING DIAGRAM

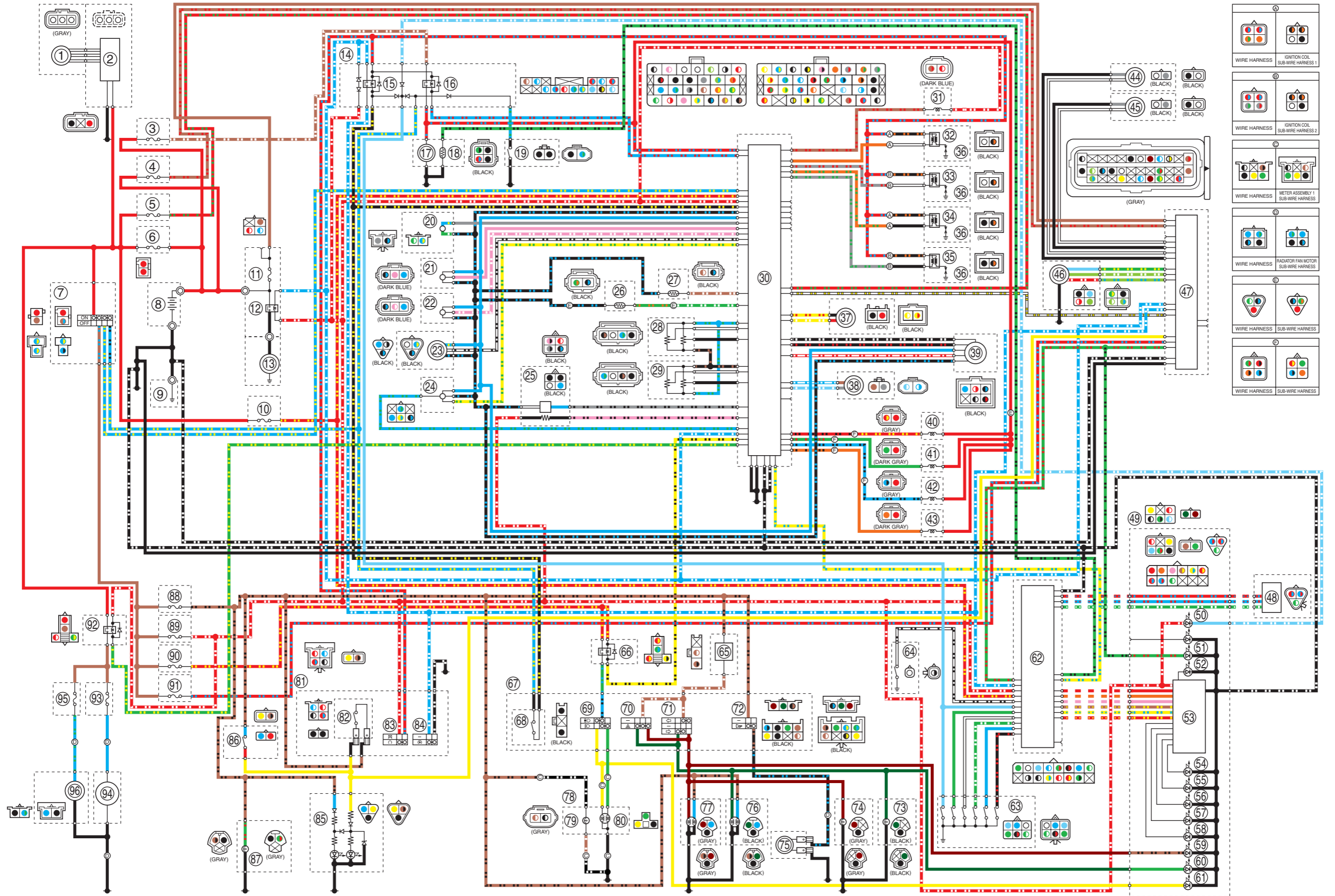

- WIRE HARNESS IGNITION COIL SUB-WIRE HARNESS 1
- WIRE HARNESS IGNITION COIL SUB-WIRE HARNESS 2
- WIRE HARNESS METER ASSEMBLY 1 SUB-WIRE HARNESS
- WIRE HARNESS RADIATOR FAN MOTOR SUB-WIRE HARNESS
- WIRE HARNESS SUB-WIRE HARNESS
- WIRE HARNESS SUB-WIRE HARNESS